

1-Mbit SPI Serial SRAM with SDI and SQI Interface

Device Selection Table

Part Number	Vcc Range	Temp. Ranges	Dual I/O (SDI)	Quad I/O (SQI)	Max. Clock Frequency	Packages
23A1024	1.7V-2.2V	I, E	Yes	Yes	20 MHz ⁽¹⁾	SN, ST, P
23LC1024	2.5V-5.5V	I, E	Yes	Yes	20 MHz ⁽¹⁾	SN, ST, P

Note 1: 16 MHz for E-temp.

Features

- SPI Bus Interface:
 - SPI compatible
 - SDI (dual) and SQI (quad) compatible
 - 20 MHz Clock rate for all modes
- Low-Power CMOS Technology:
 - Read current: 3 mA at 5.5V, 20 MHz
 - Standby current: 4 μ A at +85°C
- Unlimited Read and Write Cycles
- Zero Write Time
- 128-Kbit x 8-bit Organization:
 - 32-byte page
- Byte, Page and Sequential Mode for Reads and Writes
- High Reliability
- Temperature Ranges Supported:
 - Industrial (I): -40°C to +85°C
 - Extended (E): -40°C to +125°C
- Automotive AEC-Q100 Qualified
- RoHS Compliant

Packages

- 8-Lead PDIP
- 8-Lead SOIC
- 8-Lead TSSOP

Package Types (not to scale)

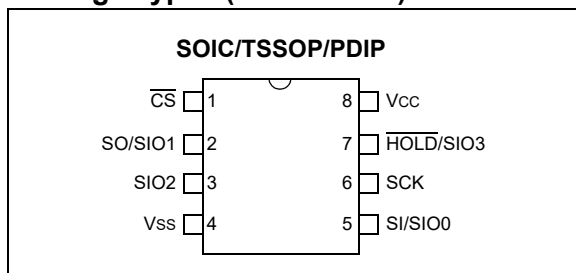

Description

The Microchip Technology Inc. 23X1024⁽¹⁾ are 1-Mbit Serial SRAM devices. The memory is accessed via a simple Serial Peripheral Interface (SPI) compatible serial bus. The bus signals required are a clock input (SCK), a data in line (SI) and a data out line (SO). Access to the device is controlled through a Chip Select (\overline{CS}) input. Additionally, SDI (Serial Dual Interface) and SQI (Serial Quad Interface) is supported if your application needs faster data rates.

This device also supports unlimited reads and writes to the memory array.

Pin Function Table

Name	Function
\overline{CS}	Chip Select Input Pin
SO/SIO1	Serial Output/SDI/SQI Pin
SIO2	SQI Pin
Vss	Ground Pin
SI/SIO0	Serial Input/SDI/SQI Pin
SCK	Serial Clock Pin
HOLD/SIO3	Hold/SQI Pin
Vcc	Power Supply Pin

Note 1: 23X1024 is used in this document as a generic part number for the 23A1024/23LC1024 devices.

23A1024/23LC1024

1.0 ELECTRICAL CHARACTERISTICS

Absolute Maximum Ratings (†)

V _{CC}	6.5V
All Inputs and Outputs w.r.t. V _{SS}	-0.3V to V _{CC} +0.3V
Storage Temperature.....	-65°C to +150°C
Ambient Temperature under Bias.....	-40°C to +125°C

† NOTICE: Stresses above those listed under “Absolute Maximum Ratings” may cause permanent damage to the device. This is a stress rating only and functional operation of the device at those or any other conditions above those indicated in the operational listings of this specification is not implied. Exposure to maximum rating conditions for an extended period of time may affect device reliability.

TABLE 1-1: DC CHARACTERISTICS

DC CHARACTERISTICS			Electrical Characteristics: Industrial (I): TA = -40°C to +85°C Extended (E): TA = -40°C to +125°C				
Param. No.	Symbol	Characteristic	Min.	Typical ⁽³⁾	Max.	Units	Test Conditions
D001	V _{CC}	Supply Voltage	1.7	—	2.2	V	23A1024
			2.5	—	5.5	V	23LC1024
D002	V _{IH}	High-level Input Voltage	0.7 V _{CC}	—	V _{CC} + 0.3	V	
D003	V _{IL}	Low-level Input Voltage	-0.3	—	0.2 V _{CC}	V	23A1024
					0.1 V _{CC}	V	23LC1024
D004	V _{OL}	Low-level Output Voltage	—	—	0.2	V	I _{OL} = 1 mA
D005	V _{OH}	High-level Output Voltage	V _{CC} - 0.5	—	—	V	I _{OH} = -400 μA
D006	I _{LI}	Input Leakage Current	—	—	±1	μA	$\overline{CS} = V_{CC}$, V _{IN} = V _{SS} OR V _{CC}
D007	I _{LO}	Output Leakage Current	—	—	±1	μA	$\overline{CS} = V_{CC}$, V _{OUT} = V _{SS} OR V _{CC}
D008	I _{CCREAD}	Operating Current	—	1	10	mA	F _{CLK} = 20 MHz; S _O = 0, 2.2V
				3	10	mA	F _{CLK} = 20 MHz; S _O = 0, 5.5V
D009	I _{CCS}	Standby Current	—	1	4	μA	$\overline{CS} = V_{CC} = 2.2V$, Inputs tied to V _{CC} or V _{SS} , I-Temp
				—	12	μA	$\overline{CS} = V_{CC} = 2.2V$, Inputs tied to V _{CC} or V _{SS} , E-Temp
				4	10	μA	$\overline{CS} = V_{CC} = 5.5V$, Inputs tied to V _{CC} or V _{SS} , I-Temp
				—	20	μA	$\overline{CS} = V_{CC} = 5.5V$, Inputs tied to V _{CC} or V _{SS} , E-Temp
D010	C _{INT}	Input Capacitance	—	—	7	pF	V _{CC} = 5.0V, f = 1 MHz, T _A = 25°C (Note 1)
D011	V _{DR}	RAM Data Retention Voltage	—	1.0	—	V	(Note 2)

Note 1: This parameter is periodically sampled and not 100% tested.

Note 2: This is the limit to which V_{CC} can be lowered without losing RAM data. This parameter is periodically sampled and not 100% tested.

Note 3: Typical measurements taken at room temperature.

TABLE 1-2: AC CHARACTERISTICS

AC CHARACTERISTICS			Electrical Characteristics: Industrial (I): TA = -40°C to +85°C Extended (E): TA = -40°C to +125°C			
Param. No.	Symbol	Characteristic	Min.	Max.	Units	Test Conditions
1	FCLK	Clock Frequency	—	20	MHz	I-Temp
				16	MHz	E-Temp
2	TCSS	$\overline{\text{CS}}$ Setup Time	25	—	ns	I-Temp
			32	—	ns	E-Temp
3	TCSH	$\overline{\text{CS}}$ Hold Time	50	—	ns	
4	TCSD	$\overline{\text{CS}}$ Disable Time	25	—	ns	I-Temp
			32	—	ns	E-Temp
5	TSU	Data Setup Time	10	—	ns	
6	THD	Data Hold Time	10	—	ns	
7	TR	CLK Rise Time	—	20	ns	Note 1
8	TF	CLK Fall Time	—	20	ns	Note 1
9	THI	Clock High Time	25	—	ns	I-Temp
			32	—	ns	E-Temp
10	TLO	Clock Low Time	25	—	ns	I-Temp
			32	—	ns	E-Temp
11	TCLD	Clock Delay Time	25	—	ns	I-Temp
			32	—	ns	E-Temp
12	TV	Output Valid from Clock Low	—	25	ns	I-Temp
				32	ns	E-Temp
13	THO	Output Hold Time	0	—	ns	Note 1
14	TDIS	Output Disable Time	—	20	ns	
15	THS	$\overline{\text{HOLD}}$ Setup Time	10	—	ns	
16	THH	$\overline{\text{HOLD}}$ Hold Time	10	—	ns	
17	THZ	$\overline{\text{HOLD}}$ Low to Output High-Z	—	10	ns	
18	THV	$\overline{\text{HOLD}}$ High to Output Valid	—	50	ns	

Note 1: This parameter is periodically sampled and not 100% tested.

TABLE 1-3: AC TEST CONDITIONS

AC Waveform	
Input Pulse Level	0.1 Vcc to 0.9 Vcc
Input Rise/Fall Time	5 ns
C _L = 30 pF	—
Timing Measurement Reference Level	
Input	0.5 Vcc
Output	0.5 Vcc

23A1024/23LC1024

FIGURE 1-1: HOLD TIMING

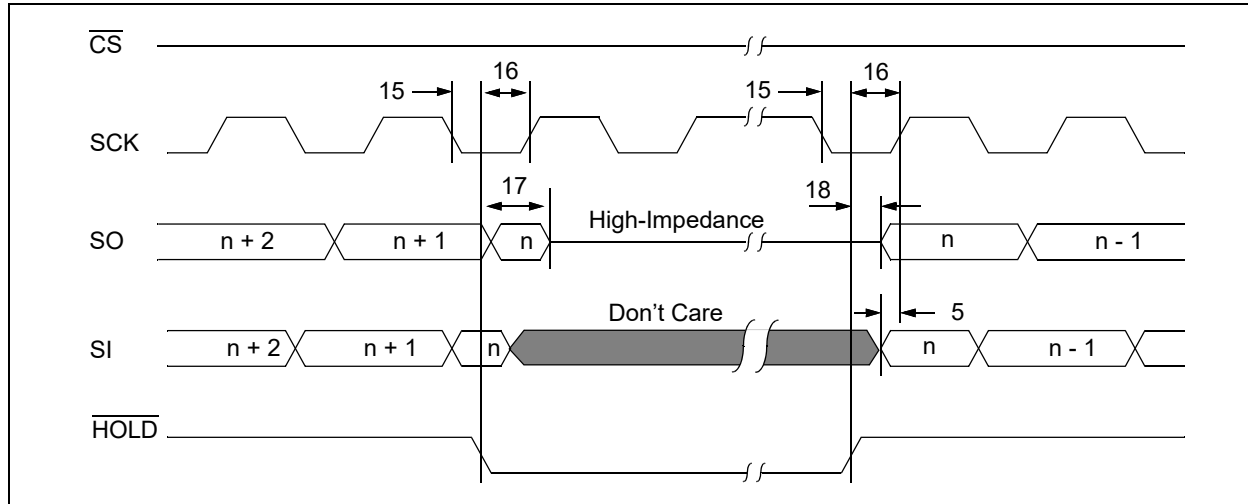

FIGURE 1-2: SERIAL INPUT TIMING (SPI MODE)

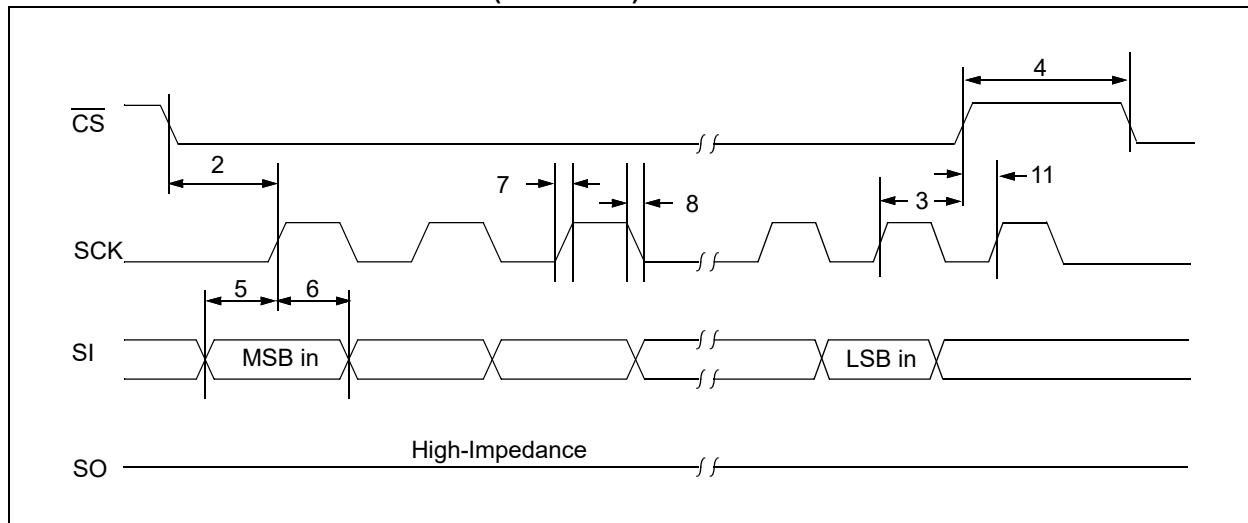
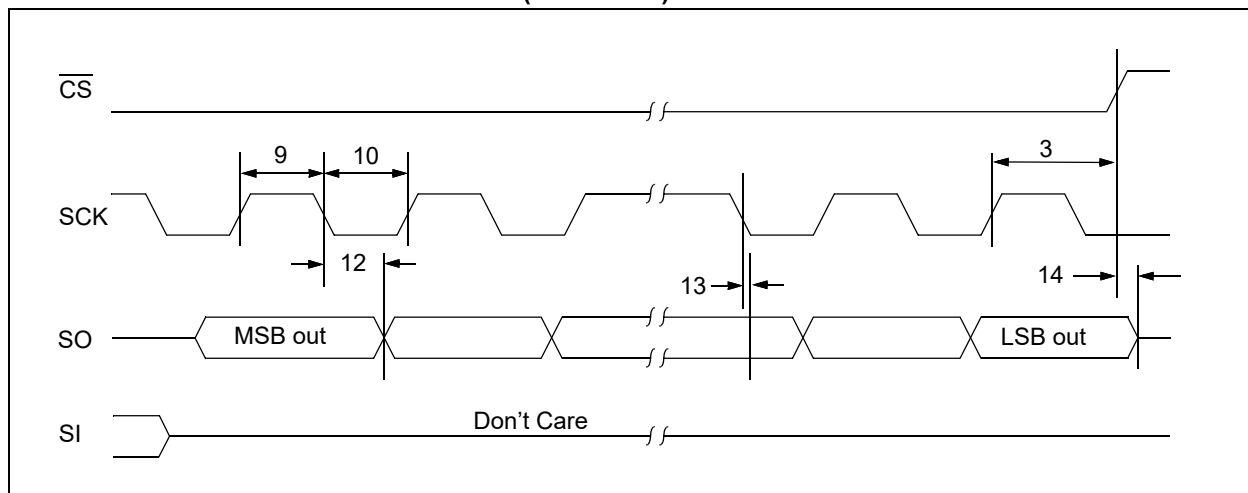

FIGURE 1-3: SERIAL OUTPUT TIMING (SPI MODE)



2.0 FUNCTIONAL DESCRIPTION

2.1 Principles of Operation

The 23X1024 devices are 1-Mbit Serial SRAM designed to interface directly with the Serial Peripheral Interface (SPI) port of many of today's popular microcontroller families, including Microchip's PIC[®] microcontrollers. It may also interface with microcontrollers that do not have a built-in SPI port by using discrete I/O lines programmed properly in firmware to match the SPI protocol. In addition, the 23X1024 devices are capable of operation in SDI and SQI modes. In SDI mode, the SI and SO data lines are bidirectional, allowing the transfer of two bits per clock pulse. In SQI mode, two additional data lines enable the transfer of four bits per clock pulse.

The 23X1024 devices contain an 8-bit instruction register. The device is accessed via the SI pin, with data being clocked in on the rising edge of SCK. The \overline{CS} pin must be low for the entire operation.

Table 2-1 contains a list of the possible instruction bytes and format for device operation. All instructions, addresses and data are transferred MSB first, LSB last.

2.2 Modes of Operation

The 23X1024 has three modes of operation that are selected by setting bits 7 and 6 in the MODE register. The modes of operation are Byte, Page and Burst.

Byte Operation – is selected when bits 7 and 6 in the MODE register are set to 00. In this mode, the read/write operations are limited to only one byte. The Command followed by the 24-bit address is clocked into the device and the data to/from the device is transferred on the next eight clocks (Figure 2-1, Figure 2-2).

Page Operation – is selected when bits 7 and 6 in the MODE register are set to 10. The 23X1024 has 4096 pages of 32 bytes. In this mode, the read and write operations are limited to within the addressed page (the address is automatically incremented internally). If the data being read or written reaches the page boundary, then the internal address counter will increment to the start of the page (Figure 2-3, Figure 2-4).

Sequential Operation – is selected when bits 7 and 6 in the MODE register are set to 01. Sequential operation allows the entire array to be written to and read from. The internal address counter is automatically incremented and page boundaries are ignored. When the internal address counter reaches the end of the array, the address counter will roll over to 0x00000 (Figure 2-5, Figure 2-6).

2.3 Read Sequence

The device is selected by pulling \overline{CS} low. The 8-bit READ instruction is transmitted to 23X1024 followed by the 24-bit address, with the first seven MSB's of the address being "don't care" bits. After the correct READ instruction and address are sent, the data stored in the memory at the selected address is shifted out on the SO pin.

If operating in Sequential mode, the data stored in the memory at the next address can be read sequentially by continuing to provide clock pulses. The internal Address Pointer is automatically incremented to the next higher address after each byte of data is shifted out. When the highest address is reached (1FFFFh), the address counter rolls over to address 00000h, allowing the read cycle to be continued indefinitely. The read operation is terminated by raising the \overline{CS} pin.

2.4 Write Sequence

Prior to any attempt to write data to the 23X1024, the device must be selected by bringing \overline{CS} low.

Once the device is selected, the Write command can be started by issuing a WRITE instruction, followed by the 24-bit address, with the first seven MSB's of the address being "don't care" bits and then the data to be written. A write is terminated by the \overline{CS} being brought high.

If operating in Page mode, after the initial data byte is shifted in, additional bytes can be shifted into the device. The Address Pointer is automatically incremented. This operation can continue for the entire page (32 bytes) before data will start to be overwritten.

If operating in Sequential mode, after the initial data byte is shifted in, additional bytes can be clocked into the device. The internal Address Pointer is automatically incremented. When the Address Pointer reaches the highest address (1FFFFh), the address counter rolls over to (00000h). This allows the operation to continue indefinitely, however, previous data will be overwritten.

23A1024/23LC1024

TABLE 2-1: INSTRUCTION SET

Instruction Name	Instruction Format	Hex Code	Description
READ	0000 0011	0x03	Read data from memory array beginning at selected address
WRITE	0000 0010	0x02	Write data to memory array beginning at selected address
EDIO	0011 1011	0x3B	Enter Dual I/O access (enter SDI bus mode)
EQIO	0011 1000	0x38	Enter Quad I/O access (enter SQI bus mode)
RSTIO	1111 1111	0xFF	Reset Dual and Quad I/O access (revert to SPI bus mode)
RDMR	0000 0101	0x05	Read Mode Register
WRMR	0000 0001	0x01	Write Mode Register

FIGURE 2-1: BYTE READ SEQUENCE (SPI MODE)

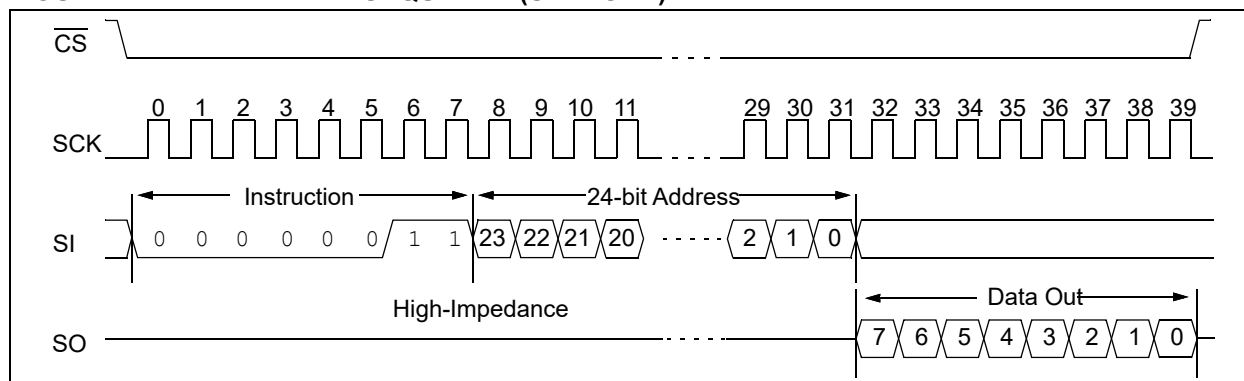

FIGURE 2-2: BYTE WRITE SEQUENCE (SPI MODE)

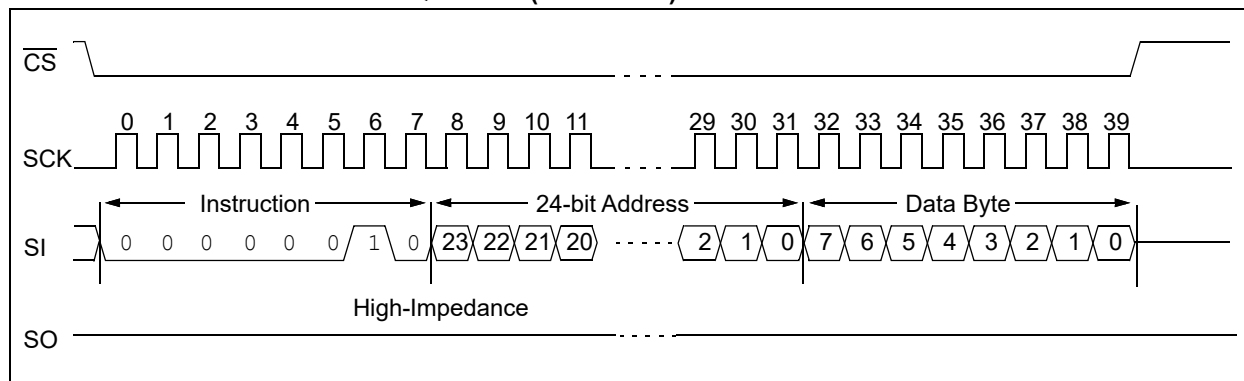

FIGURE 2-3: PAGE READ SEQUENCE (SPI MODE)

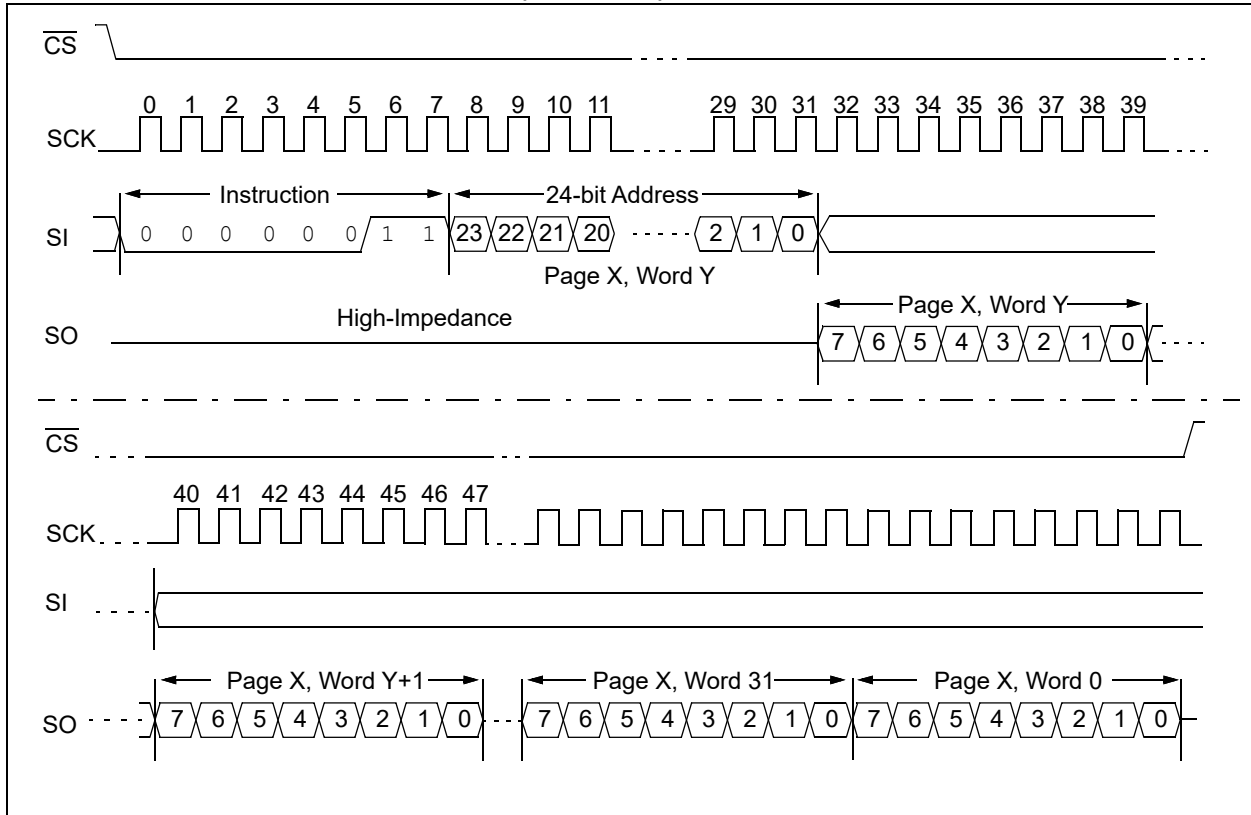
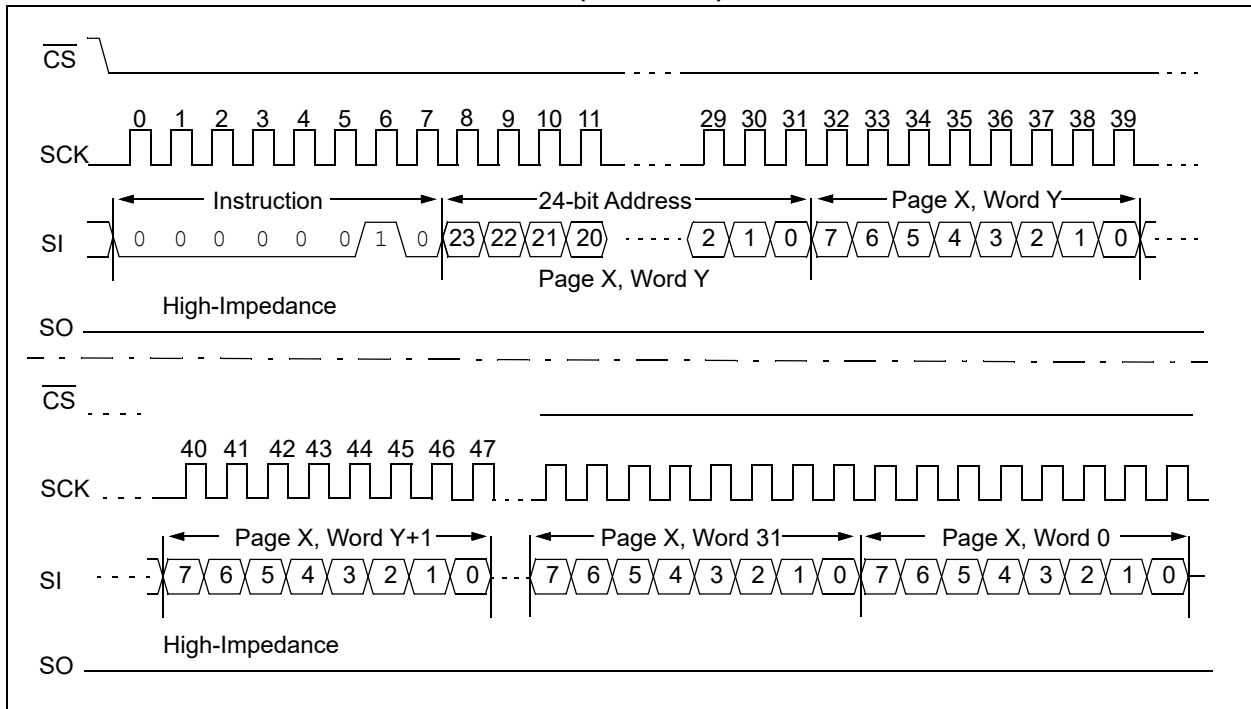

FIGURE 2-4: PAGE WRITE SEQUENCE (SPI MODE)



23A1024/23LC1024

FIGURE 2-5: SEQUENTIAL READ SEQUENCE (SPI MODE)

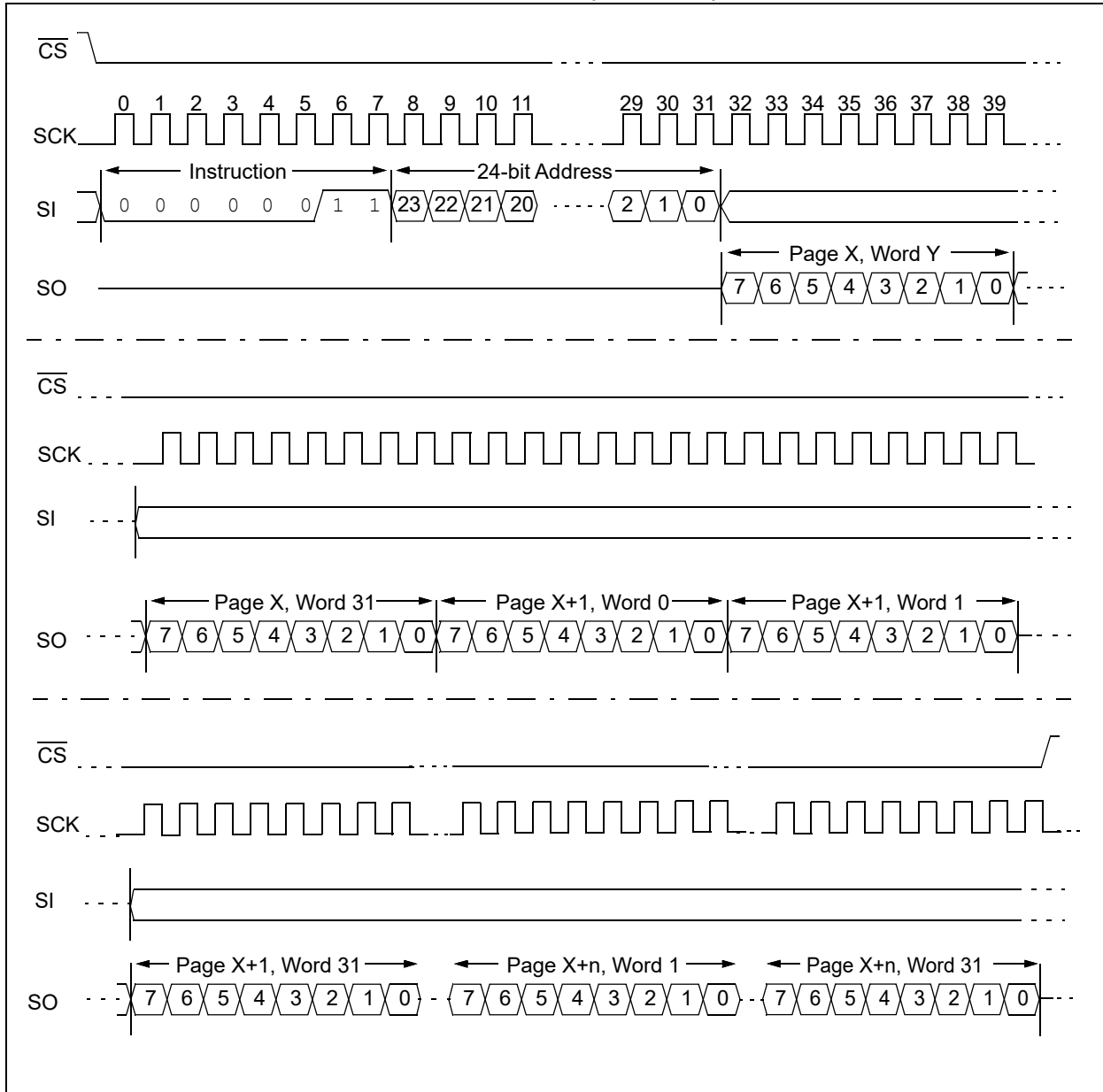
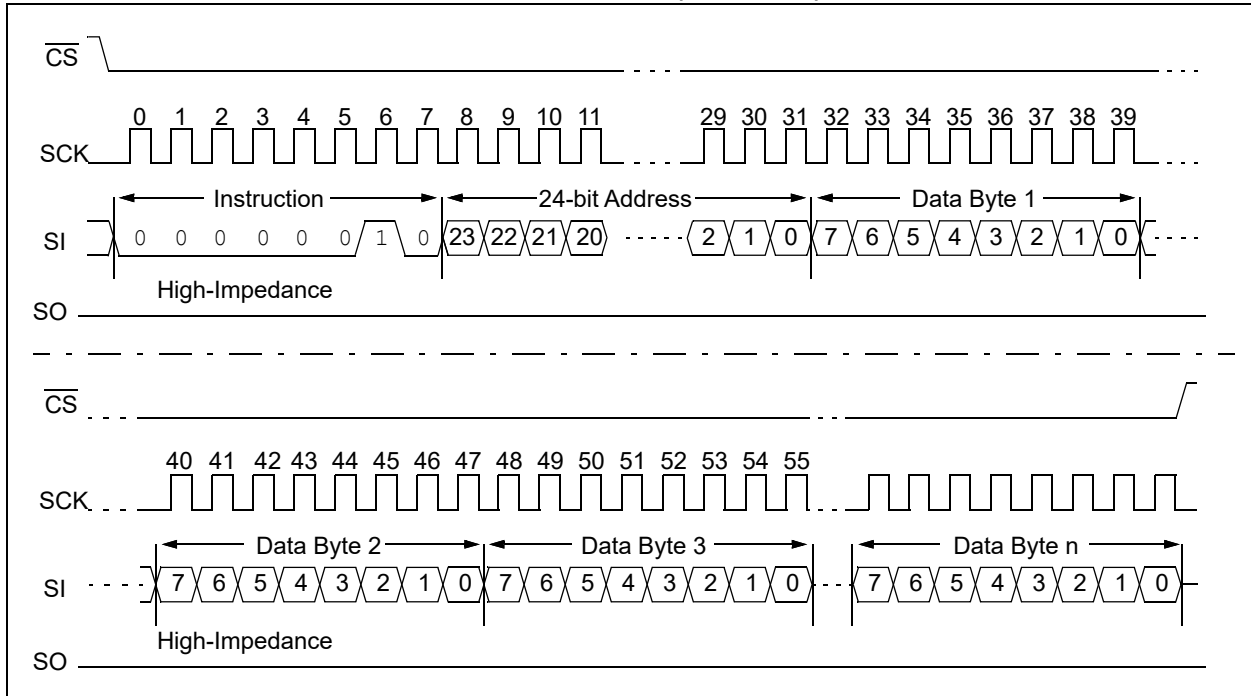

FIGURE 2-6: SEQUENTIAL WRITE SEQUENCE (SPI MODE)



23A1024/23LC1024

2.5 Read Mode Register Instruction (RDMR)

The Read Mode Register instruction (R_{DMR}) provides access to the MODE register. The MODE register may be read at any time. The MODE register is formatted as follows:

TABLE 2-2: MODE REGISTER

7	6	5	4	3	2	1	0
W/R	W/R	-	-	-	-	-	-
MODE	MODE	0	0	0	0	0	0

W/R = writable/readable

The mode bits indicate the operating mode of the SRAM. The possible modes of operation are:

- 0 0 = Byte mode
- 1 0 = Page mode
- 0 1 = Sequential mode (default operation)
- 1 1 = Reserved

Bits 0 through 5 are reserved and should always be set to '0'.

See [Figure 2-7](#) for the R_{DMR} timing sequence.

FIGURE 2-7: READ MODE REGISTER TIMING SEQUENCE (RDMR)

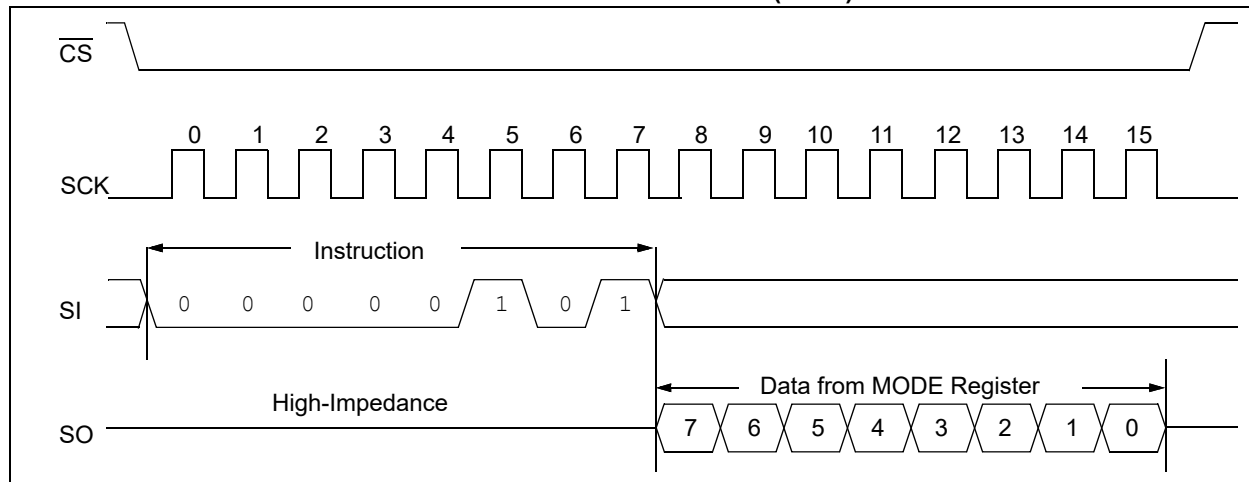

2.6 Write Mode Register Instruction (WRMR)

The Write Mode Register instruction (WRMR) allows the user to write to the bits in the MODE register as shown in Table 2-2. This allows for setting of the Device operating mode. Several of the bits in the MODE register must be cleared to '0'. See Figure 2-8 for the WRMR timing sequence.

FIGURE 2-8: WRITE MODE REGISTER TIMING SEQUENCE (WRMR)

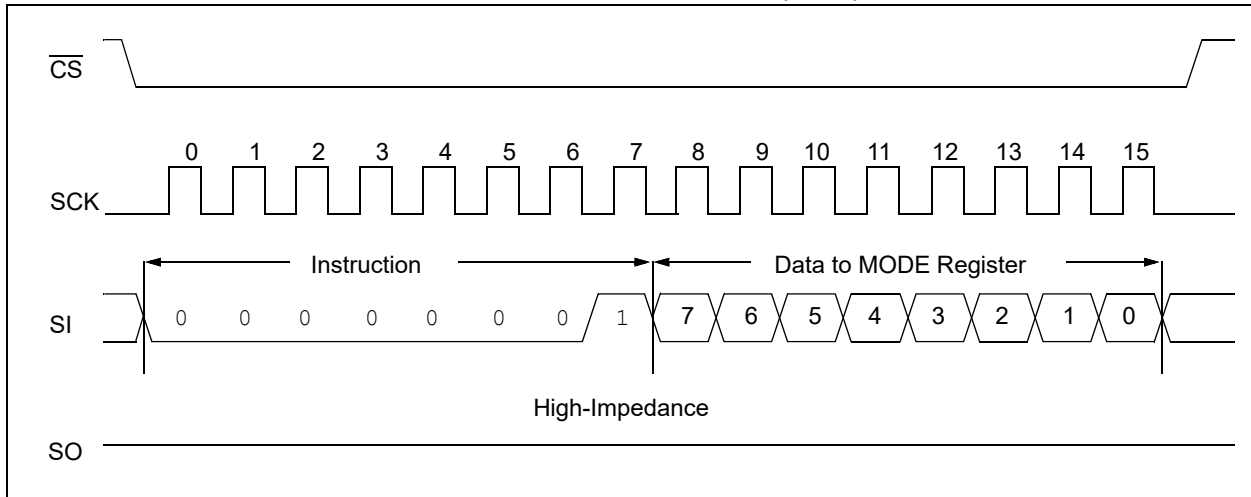

2.7 Power-On State

The 23A1024/23LC1024 powers on in the following state:

- The device is in low-power Standby mode ($\overline{CS} = 1$)
- A high-to-low-level transition on \overline{CS} is required to enter active state

23A1024/23LC1024

3.0 PIN DESCRIPTIONS

The descriptions of the pins are listed in [Table 3-1](#).

TABLE 3-1: PIN FUNCTION TABLE

SOIC/PDIP/TSSOP	Symbol	Description
1	\overline{CS}	Chip Select Input
2	SO/SIO1	Serial Output (SPI)/Serial I/O 1 (SDI)/Serial I/O 1 (SQI)
3	SIO2	Serial I/O 2 (SQI)
4	Vss	Ground
5	SI/SIO0	Serial Input (SPI)/Serial I/O 0 (SDI)/Serial I/O 0 (SQI)
6	SCK	Serial Clock Input
7	\overline{HOLD} /SIO3	Hold/Serial I/O 3
8	Vcc	Power Supply

FIGURE 3-1: SPI, SDI and SQI Pin Configurations

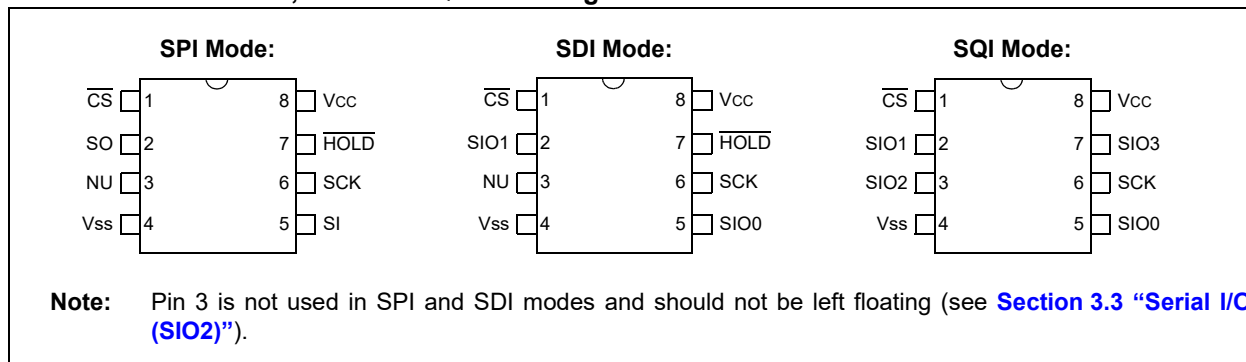

3.1 Chip Select (\overline{CS})

A low level on this pin selects the device. A high level deselects the device and forces it into Standby mode. When the device is deselected, SO goes to the high-impedance state, allowing multiple parts to share the same SPI bus. After power-up, a low level on \overline{CS} is required, prior to any sequence being initiated.

3.2 Serial Output, Serial I/O (SO/SIO1)

The SO/SIO1 pin is used to transfer data out of the 23X1024 devices when the SPI bus is being used. When in SDI or SQI bus modes, the SO/SIO1 pin is a bidirectional I/O pin. Data is shifted out on this pin after the falling edge of the serial clock and it is latched in on the rising edge of the serial clock.

3.3 Serial I/O 2 (SIO2)

The SIO2 pin is a bidirectional I/O pin used only in SQI mode. If not using SQI bus mode, this pin should not be left floating. Deciding to pull the SIO2 pin high would allow successful recovery of the bus from SQI bus mode in case an accidental EQIO command has been registered.

3.4 Serial Input, Serial I/O 0 (SI/SIO0)

The SI pin is used to transfer data into the device when the SPI bus is being used. When in SDI or SQI bus modes, the SI/SIO0 pin is a bidirectional I/O pin.

3.5 Serial Clock (SCK)

The SCK is used to synchronize the communication between a host and the 23X1024 devices. Instructions, addresses or data present on the SI pin are latched on the rising edge of the clock input, while data on the SO pin is updated after the falling edge of the clock input.

3.6 Hold, Serial I/O 3 (\overline{HOLD} /SIO3)

When the device is in SQI bus mode, pin \overline{HOLD} /SIO3 is a bidirectional I/O pin. When in SPI or SDI bus modes, the pin has the HOLD function.

The \overline{HOLD} pin is used to suspend transmission to the 23X1024 devices while in the middle of a serial sequence without having to transmit the entire sequence over again. It must be held high any time this function is not being used. Once the device is selected

and a serial sequence is underway, the $\overline{\text{HOLD}}$ pin may be pulled low to pause further serial communication without resetting the serial sequence.

The $\overline{\text{HOLD}}$ pin should be brought low while SCK is low, otherwise the HOLD function will not be invoked until the next SCK high-to-low transition. The 23X1024 devices must remain selected during this sequence. The SI and SCK levels are “don’t cares” during the time the device is paused and any transitions on these pins will be ignored. To resume serial communication, $\overline{\text{HOLD}}$ should be brought high while the SCK pin is low, otherwise serial communication will not be resumed until the next SCK high-to-low transition.

The SO line will tri-state immediately upon a high-to low transition of the $\overline{\text{HOLD}}$ pin and will begin outputting again immediately upon a subsequent low-to-high transition of the $\overline{\text{HOLD}}$ pin, independent of the state of SCK.

Hold functionality is not available when operating in SQI bus mode.

23A1024/23LC1024

4.0 DUAL AND QUAD SERIAL MODE

23X1024 also supports SDI (Serial Dual) and SQI (Serial Quad) mode of operation when used with compatible host devices. As a convention for SDI mode of operation, two bits are entered per clock using the SIO0 and SIO1 pins. Bits are clocked MSB first.

For SQI mode of operation, four bits of data are entered per clock, or one nibble per clock. The nibbles are clocked MSB first.

4.1 Dual Interface Mode

23X1024 supports Serial Dual Input (SDI) mode of operation. To enter SDI mode the EDIO command must be clocked in (Figure 4-1). It should be noted that if the MCU resets before the SRAM, the user will need to determine the serial mode of operation of the SRAM and reset it accordingly. Byte read and write sequence in SDI mode is shown in Figure 4-2 and Figure 4-3.

FIGURE 4-1: ENTER SDI MODE (EDIO) FROM SPI MODE

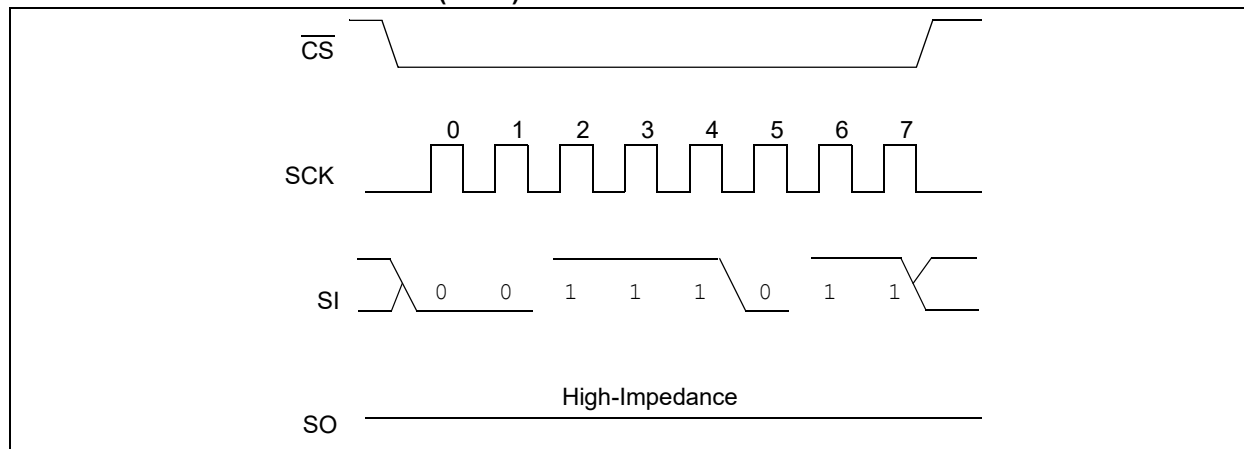

FIGURE 4-2: BYTE READ MODE SDI

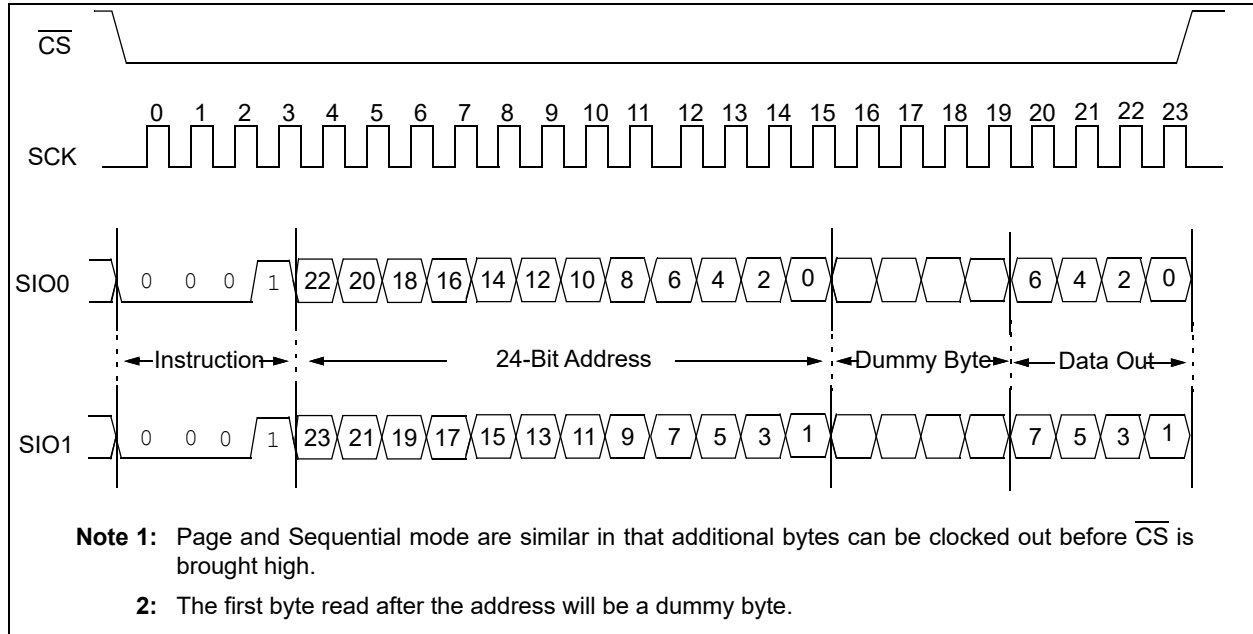
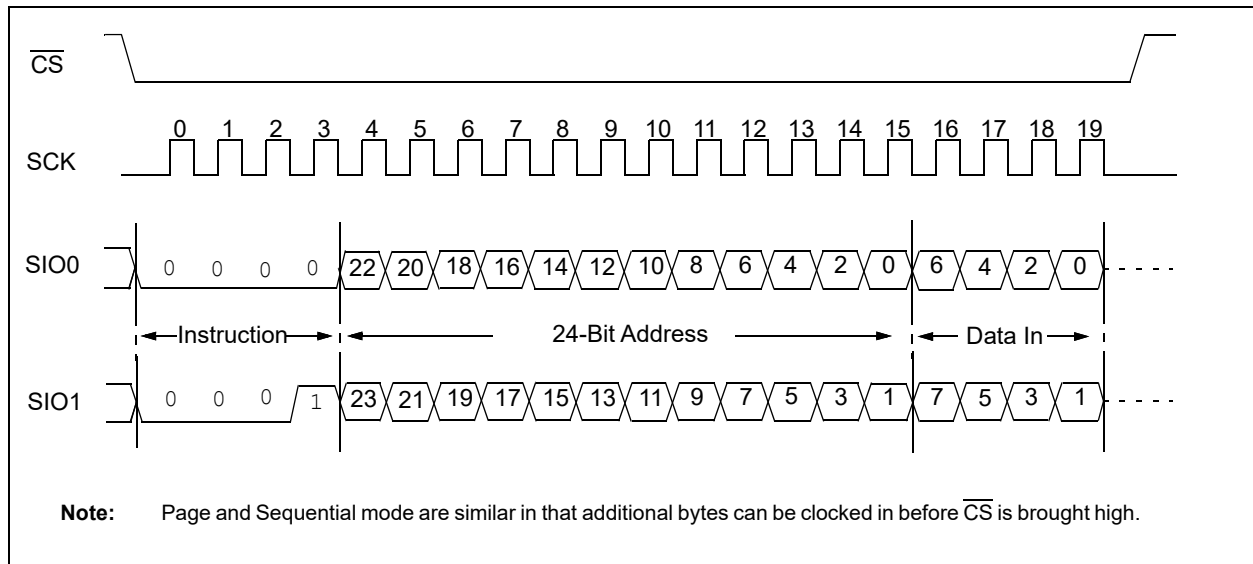

FIGURE 4-3: BYTE WRITE MODE SDI



23A1024/23LC1024

4.2 Quad Interface Mode

In addition to the Serial Dual interface (SDI) mode of operation Serial Quad Interface (SQI) is also supported. In this mode the HOLD functionality is not available. To enter SQI mode the EQIO command must be clocked in (Figure 4-4).

FIGURE 4-4: ENTER SQI MODE (EQIO) FROM SPI MODE

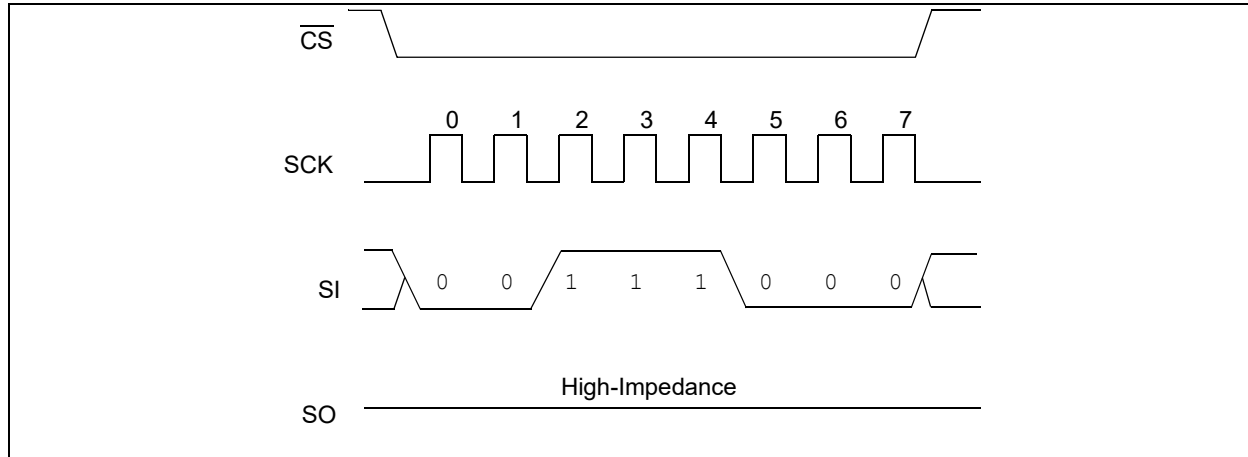

FIGURE 4-5: BYTE READ MODE SQI

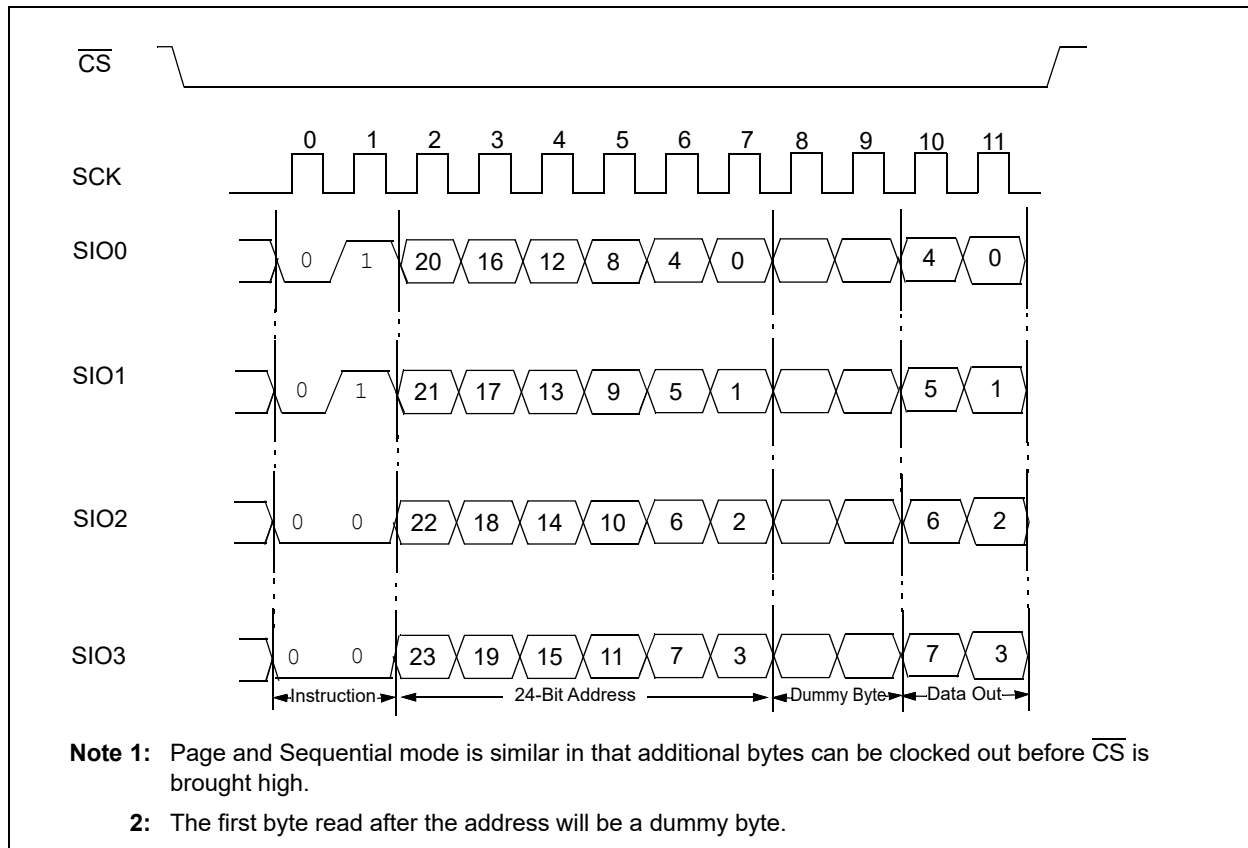
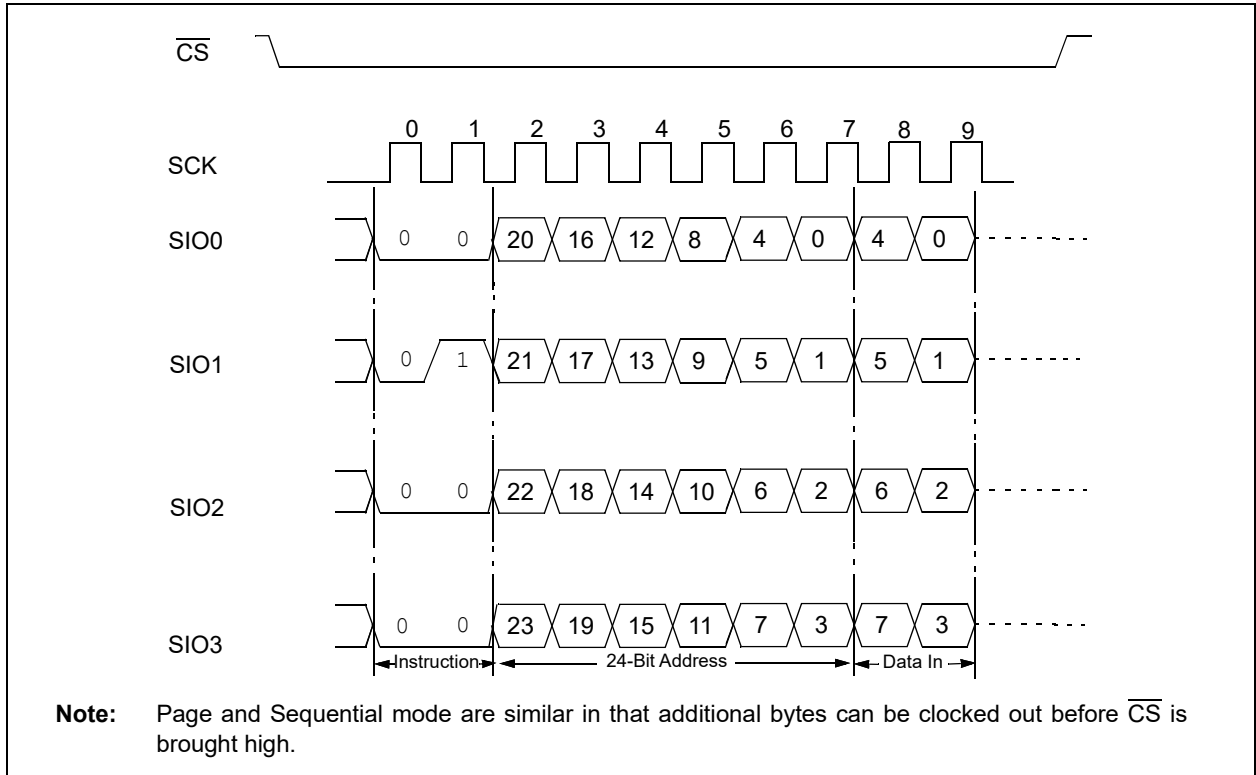

FIGURE 4-6: BYTE WRITE MODE SQI



4.3 Exit SDI or SQI Mode

To exit from SDI mode, the RSTIO command must be issued. The command must be entered in the current device configuration, either SDI or SQI, see [Figure 4-7](#) and [Figure 4-8](#).

FIGURE 4-7: RESET SDI MODE (RSTIO) – FROM SDI MODE

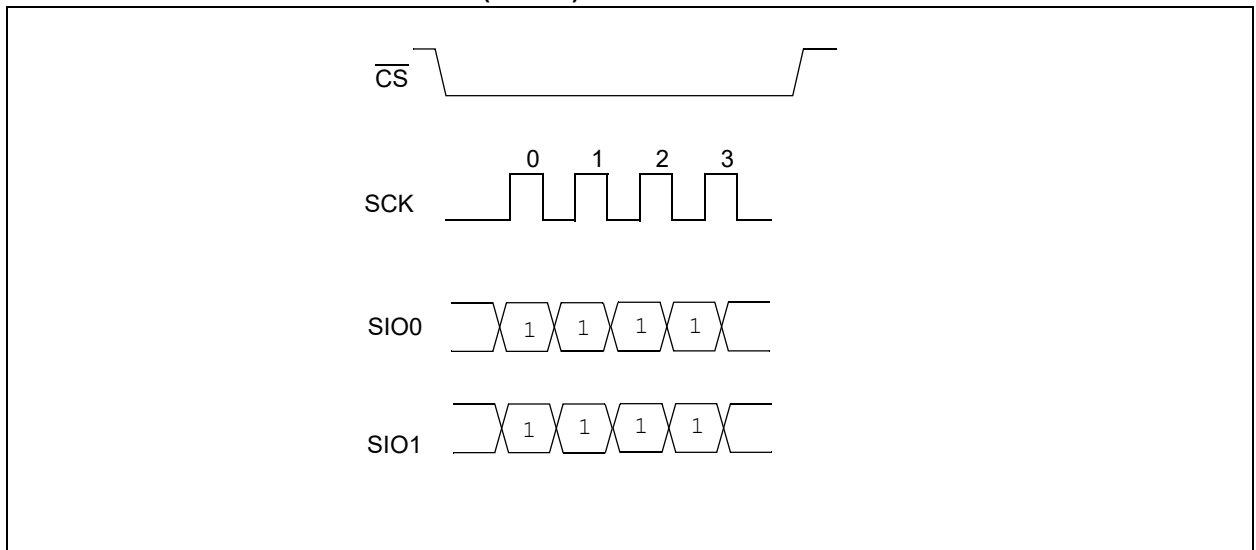

23A1024/23LC1024

FIGURE 4-8: RESET SDI/SQI MODE (RSTIO) – FROM SQI MODE

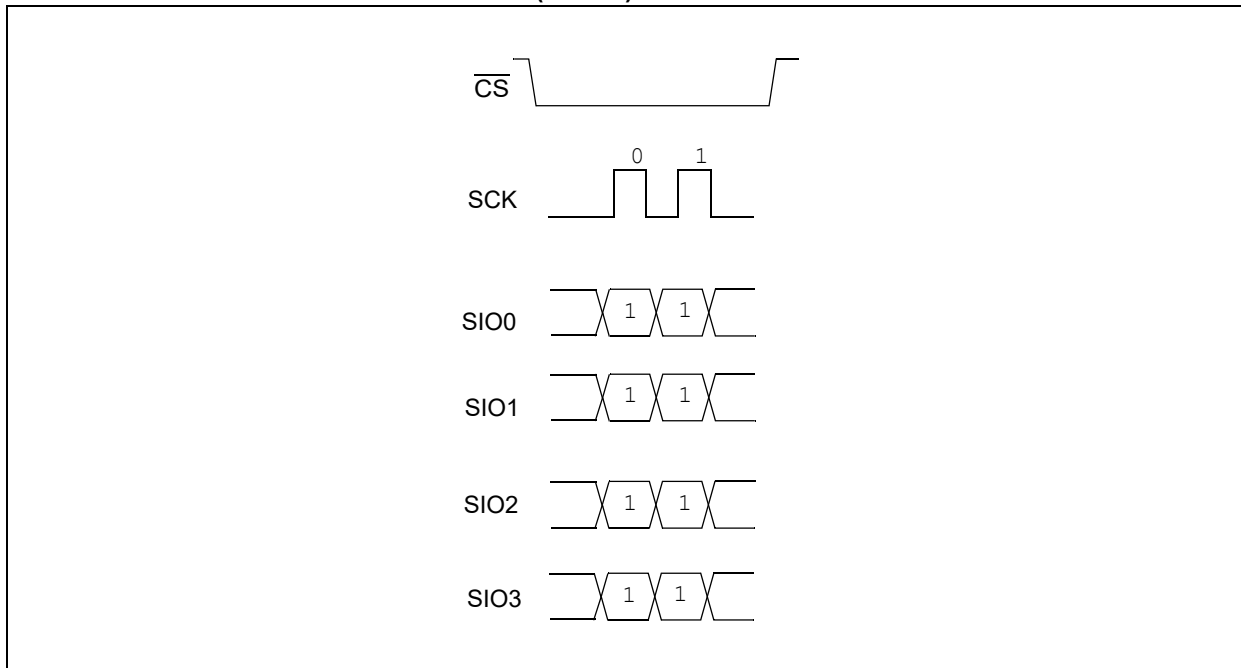

5.0 PACKAGING INFORMATION

5.1 Package Marking Information

8-Lead PDIP

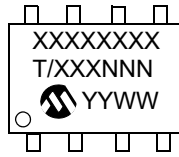

Example:

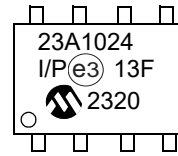

8-Lead SOIC (3.90 mm)

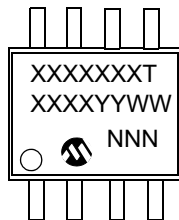

Example:

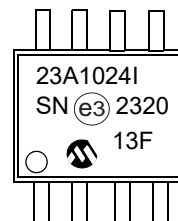

8-Lead TSSOP



Example:

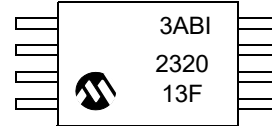

Part Number	1st Line Marking Codes		
	PDIP	SOIC	TSSOP
23A1024	23A1024	23A1024T	3ABT
23LC1024	23LC1024	23LCBT	3LBT

Note: T = Temperature grade (I, E)

Legend:	XX...X	Part number or part number code
	T	Temperature (I, E)
	Y	Year code (last digit of calendar year)
	YY	Year code (last 2 digits of calendar year)
	WW	Week code (week of January 1 is week '01')
	NNN	Alphanumeric traceability code (2 characters for small packages)
	(e3)	RoHS-compliant JEDEC® designator for Matte Tin (Sn)
Note:	For very small packages with no room for the RoHS-compliant JEDEC® designator (e3), the marking will only appear on the outer carton or reel label.	
Note:	In the event the full Microchip part number cannot be marked on one line, it will be carried over to the next line, thus limiting the number of available characters for customer-specific information.	

23A1024/23LC1024

8-Lead Plastic Dual In-Line (P) - 300 mil Body [PDIP]

Note: For the most current package drawings, please see the Microchip Packaging Specification located at <http://www.microchip.com/packaging>

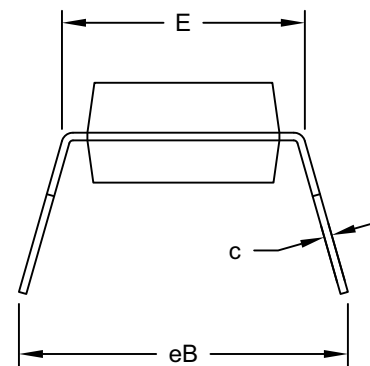
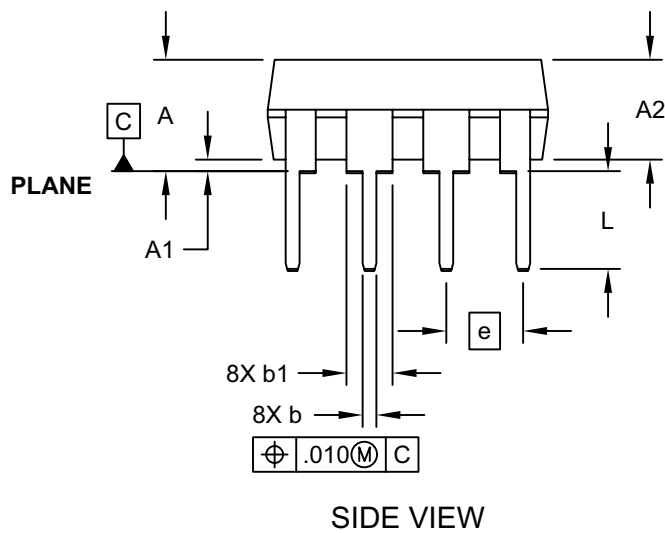
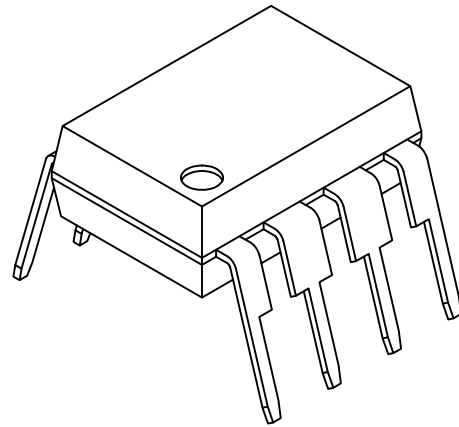
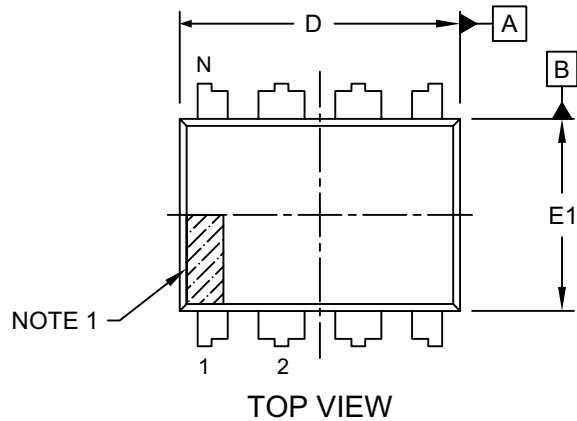

Microchip Technology Drawing No. C04-018-P Rev G Sheet 1 of 2

8-Lead Plastic Dual In-Line (P) - 300 mil Body [PDIP]

Note: For the most current package drawings, please see the Microchip Packaging Specification located at <http://www.microchip.com/packaging>

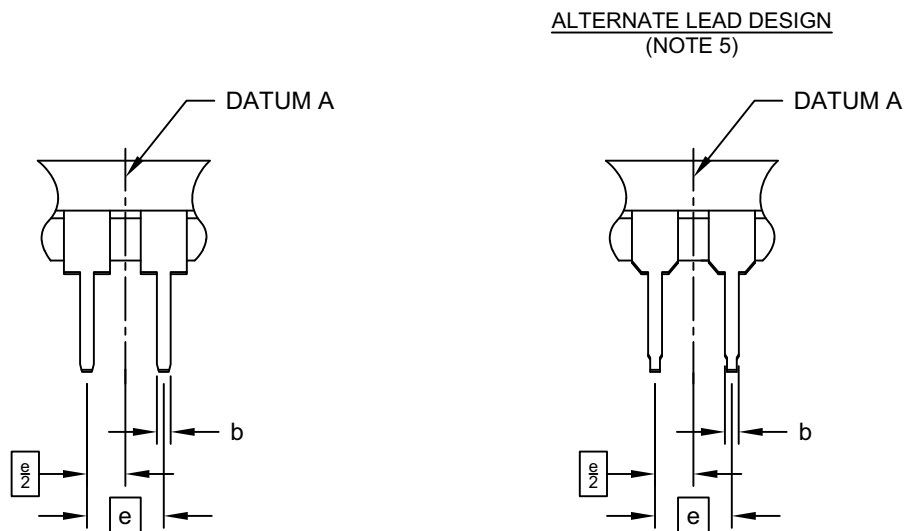

		Units	INCHES		
Dimension Limits			MIN	NOM	MAX
Number of Pins	N		8		
Pitch	e		.100 BSC		
Top to Seating Plane	A	-	-		.210
Molded Package Thickness	A2	.115	.130		.195
Base to Seating Plane	A1	.015	-		-
Shoulder to Shoulder Width	E	.290	.310		.325
Molded Package Width	E1	.240	.250		.280
Overall Length	D	.348	.365		.400
Tip to Seating Plane	L	.115	.130		.150
Lead Thickness	c	.008	.010		.015
Upper Lead Width	b1	.040	.060		.070
Lower Lead Width	b	.014	.018		.022
Overall Row Spacing	§	eB	-	-	.430

Notes:

1. Pin 1 visual index feature may vary, but must be located within the hatched area.
2. § Significant Characteristic
3. Dimensions D and E1 do not include mold flash or protrusions. Mold flash or protrusions shall not exceed .010" per side.
4. Dimensioning and tolerancing per ASME Y14.5M
BSC: Basic Dimension. Theoretically exact value shown without tolerances.
5. Lead design above seating plane may vary, based on assembly vendor.

Microchip Technology Drawing No. C04-018-P Rev G Sheet 2 of 2

23A1024/23LC1024

8-Lead Plastic Small Outline (SN) - Narrow, 3.90 mm (.150 In.) Body [SOIC]

Note: For the most current package drawings, please see the Microchip Packaging Specification located at <http://www.microchip.com/packaging>

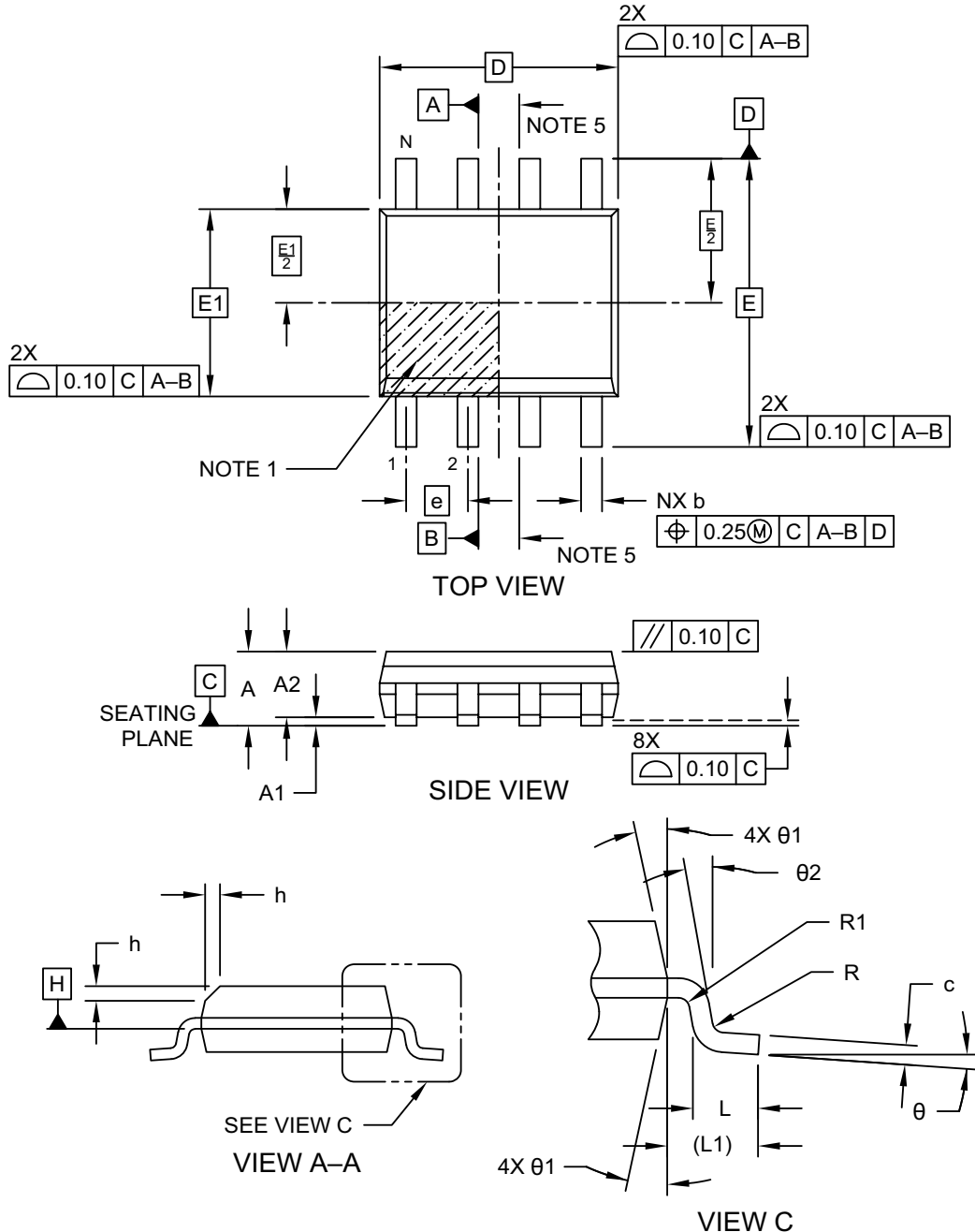

Microchip Technology Drawing No. C04-057-SN Rev K Sheet 1 of 2

23A1024/23LC1024

8-Lead Plastic Small Outline (SN) - Narrow, 3.90 mm (.150 In.) Body [SOIC]

Note: For the most current package drawings, please see the Microchip Packaging Specification located at <http://www.microchip.com/packaging>

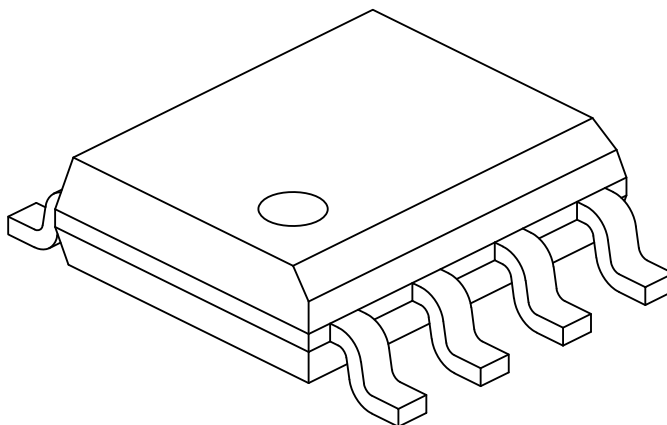

Dimension Limits	Units	MILLIMETERS		
		MIN	NOM	MAX
Number of Pins	N	8		
Pitch	e	1.27 BSC		
Overall Height	A	–	–	1.75
Molded Package Thickness	A2	1.25	–	–
Standoff §	A1	0.10	–	0.25
Overall Width	E	6.00 BSC		
Molded Package Width	E1	3.90 BSC		
Overall Length	D	4.90 BSC		
Chamfer (Optional)	h	0.25	–	0.50
Foot Length	L	0.40	–	1.27
Footprint	L1	1.04 REF		
Lead Thickness	c	0.17	–	0.25
Lead Width	b	0.31	–	0.51
Lead Bend Radius	R	0.07	–	–
Lead Bend Radius	R1	0.07	–	–
Foot Angle	θ	0°	–	8°
Mold Draft Angle	θ1	5°	–	15°
Lead Angle	θ2	0°	–	–

Notes:

1. Pin 1 visual index feature may vary, but must be located within the hatched area.
2. § Significant Characteristic
3. Dimensions D and E1 do not include mold flash or protrusions. Mold flash or protrusions shall not exceed 0.15mm per side.
4. Dimensioning and tolerancing per ASME Y14.5M
BSC: Basic Dimension. Theoretically exact value shown without tolerances.
REF: Reference Dimension, usually without tolerance, for information purposes only.
5. Datums A & B to be determined at Datum H.

Microchip Technology Drawing No. C04-057-SN Rev K Sheet 2 of 2

23A1024/23LC1024

8-Lead Plastic Small Outline (SN) - Narrow, 3.90 mm (.150 In.) Body [SOIC]

Note: For the most current package drawings, please see the Microchip Packaging Specification located at <http://www.microchip.com/packaging>

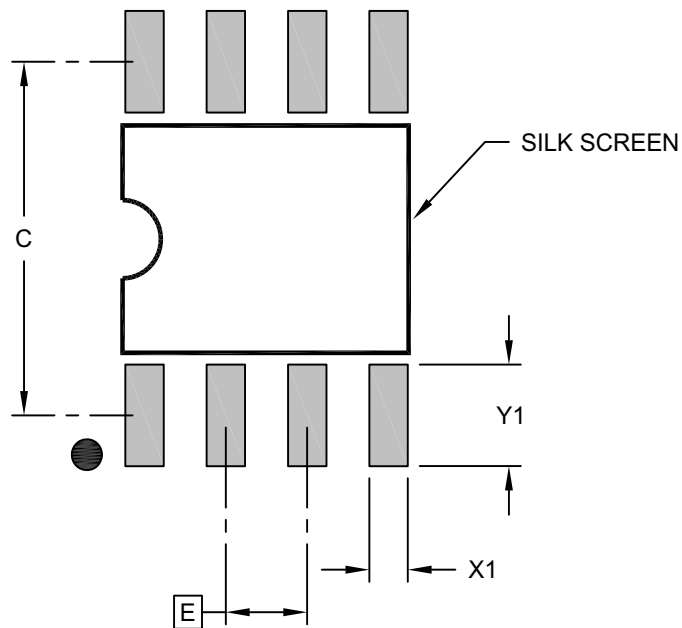

RECOMMENDED LAND PATTERN

Dimension Limits	Units	MILLIMETERS		
		MIN	NOM	MAX
Contact Pitch	E	1.27 BSC		
Contact Pad Spacing	C	5.40		
Contact Pad Width (X8)	X1			0.60
Contact Pad Length (X8)	Y1			1.55

Notes:

1. Dimensioning and tolerancing per ASME Y14.5M

BSC: Basic Dimension. Theoretically exact value shown without tolerances.

Microchip Technology Drawing C04-2057-SN Rev K

8-Lead Plastic Thin Shrink Small Outline (ST) - 4.4 mm Body [TSSOP]

Note: For the most current package drawings, please see the Microchip Packaging Specification located at <http://www.microchip.com/packaging>

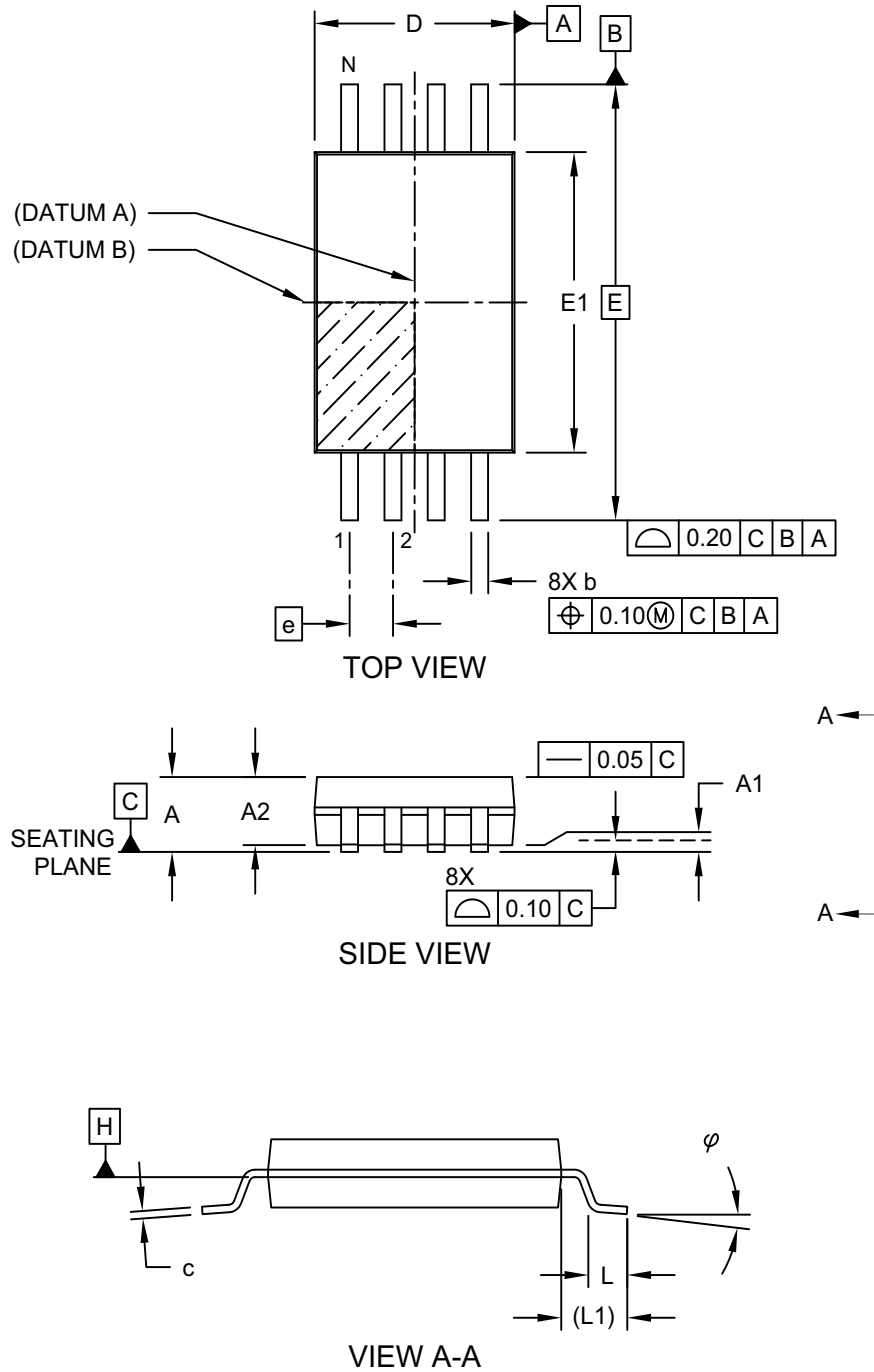

Microchip Technology Drawing C04-086 Rev C Sheet 1 of 2

23A1024/23LC1024

8-Lead Plastic Thin Shrink Small Outline (ST) - 4.4 mm Body [TSSOP]

Note: For the most current package drawings, please see the Microchip Packaging Specification located at <http://www.microchip.com/packaging>

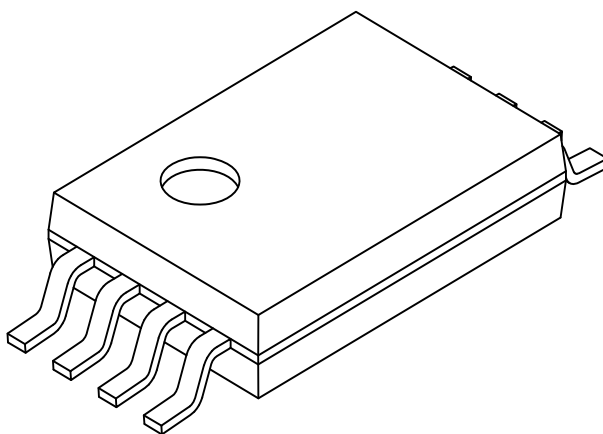

Dimension Limits	Units	MILLIMETERS		
		MIN	NOM	MAX
Number of Pins	N	8		
Pitch	e	0.65 BSC		
Overall Height	A	-	-	1.20
Molded Package Thickness	A2	0.80	1.00	1.05
Standoff	A1	0.05	-	-
Overall Width	E	6.40 BSC		
Molded Package Width	E1	4.30	4.40	4.50
Overall Length	D	2.90	3.00	3.10
Foot Length	L	0.45	0.60	0.75
Footprint	L1	1.00 REF		
Lead Thickness	c	0.09	-	0.25
Foot Angle	ϕ	0°	4°	8°
Lead Width	b	0.19	-	0.30

Notes:

1. Pin 1 visual index feature may vary, but must be located within the hatched area.
2. Dimensions D and E1 do not include mold flash or protrusions. Mold flash or protrusions shall not exceed 0.20mm per side.
3. Dimensioning and tolerancing per ASME Y14.5M

BSC: Basic Dimension. Theoretically exact value shown without tolerances.

REF: Reference Dimension, usually without tolerance, for information purposes only.

Microchip Technology Drawing C04-086 Rev C Sheet 2 of 2

8-Lead Plastic Thin Shrink Small Outline (ST) - 4.4 mm Body [TSSOP]

Note: For the most current package drawings, please see the Microchip Packaging Specification located at <http://www.microchip.com/packaging>

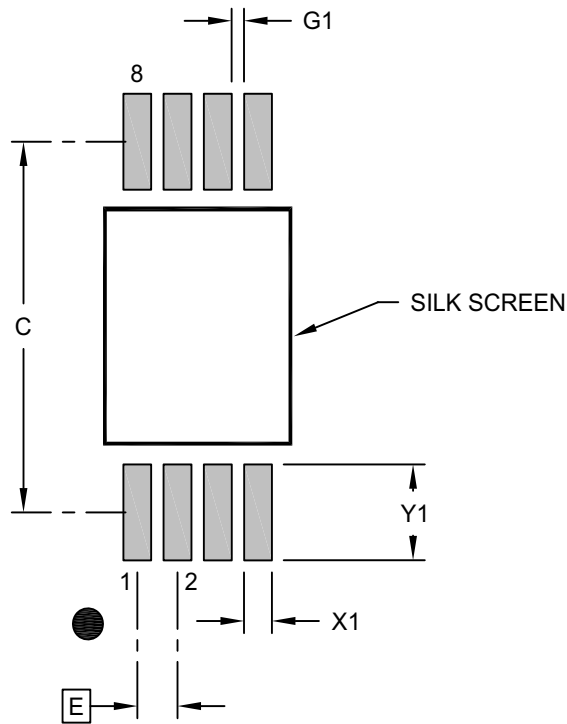

RECOMMENDED LAND PATTERN

Dimension Limits	Units	MILLIMETERS		
		MIN	NOM	MAX
Contact Pitch	E	0.65 BSC		
Contact Pad Spacing	C		5.80	
Contact Pad Width (X8)	X1			0.45
Contact Pad Length (X8)	Y1			1.50
Contact Pad to Center Pad (X6)	G1	0.20		

Notes:

1. Dimensioning and tolerancing per ASME Y14.5M
BSC: Basic Dimension. Theoretically exact value shown without tolerances.
2. For best soldering results, thermal vias, if used, should be filled or tented to avoid solder loss during reflow process

Microchip Technology Drawing C04-2086 Rev B

23A1024/23LC1024

APPENDIX A: REVISION HISTORY

Revision E (August 2023)

Updated section 3.6: Hold, Serial I/O 3 (HOLD/SIO3).

Revision D (July 2022)

- Replaced terminology “Master” and “Slave” with “Host” and “Client” respectively.
- Updated PDIP, SOIC and TSSOP package drawings.
- Added Automotive Product Identification System.

Revision C (January 2015)

- Updated Features section.
- Updated Description section.
- Updated Section 2.0, Functional Description.
- Updated Table 2-1.
- Updated Section 3.0, Pin Descriptions.
- Updated Table 3-1.
- Updated Section 4.0, Dual and Quad Serial Mode.
- Minor typographical corrections.

Revision B (November 2013)

Added E-temp specs.

Revision A (July 2012)

Initial release.

THE MICROCHIP WEBSITE

Microchip provides online support via our website at <https://www.microchip.com>. This website is used to make files and information easily available to customers. Some of the available content includes:

- **Product Support** – Data sheets and errata, application notes and sample programs, design resources, user's guides and hardware support documents, the latest software releases and archived software
- **General Technical Support** – Frequently Asked Questions (FAQs), technical support requests, online discussion groups and a Microchip design partner program member listing
- **Business of Microchip** – Product selector and ordering guides, the latest Microchip press releases, a listing of seminars and events, listings of Microchip sales offices, distributors and factory representatives

PRODUCT CHANGE NOTIFICATION SERVICE

Microchip's product change notification service helps keep customers current on Microchip products. Subscribers will receive email notifications whenever there are changes, updates, revisions or errata related to a specified product family or development tool of interest.

To register, go to <https://www.microchip.com/pcn> and follow the registration instructions.

CUSTOMER SUPPORT

Users of Microchip products can receive assistance through several channels:

- Distributor or Representative
- Local Sales Office
- Embedded Solutions Engineer (ESE)
- Technical Support

Customers should contact their distributor, representative or ESE for support. Local sales offices are also available to help customers. A listing of sales offices and locations is included in this document.

Technical support is available through the website at: <https://www.microchip.com/support>

23A1024/23LC1024

PRODUCT IDENTIFICATION SYSTEM (NON-AUTOMOTIVE)

To order or obtain information, e.g., on pricing or delivery, refer to the factory or the listed sales office.

<u>PART NO.</u>	<u>X⁽¹⁾</u>	<u>-X</u>	<u>XX</u>
Device	Tape and Reel Option	Temperature Range	Package
Device:	23A1024:	1-Mbit, 1.7V - 2.2V, SPI Serial SRAM	
	23LC1024:	1-Mbit, 2.5V - 5.5V, SPI Serial SRAM	
Tape and Reel:	Blank =	Standard packaging (tube)	
	T =	Tape and Reel ⁽¹⁾	
Temperature Range:	I =	-40°C to +85°C (Industrial)	
	E =	-40°C to +125°C (Extended)	
Package:	P =	Plastic PDIP (300 mil body), 8-lead	
	SN =	Plastic SOIC (3.90 mm body), 8-lead	
	ST =	Plastic TSSOP (4.4 mm body), 8-lead	

Examples:

- a) 23A1024-I/ST: 1-Mbit, 1.7V-2.2V Serial SRAM, Industrial temp., TSSOP package
- b) 23LC1024T-I/SN: 1-Mbit, 2.5V-5.5V Serial SRAM, Industrial temp., Tape and Reel, SOIC package
- c) 23LC1024-I/P: 1-Mbit, 2.5V-5.5V Serial SRAM, Industrial temp., PDIP package
- d) 23A1024-E/ST: 1-Mbit, 1.7V-2.2V Serial SRAM, Extended temp., TSSOP package
- e) 23LC1024T-E/SN: 1-Mbit, 2.5V-5.5V Serial SRAM, Extended temp., Tape and Reel, SOIC package
- f) 23LC1024-E/P: 1-Mbit, 2.5V-5.5V Serial SRAM, Extended temp., PDIP package

Note 1: Tape and Reel identifier only appears in the catalog part number description. This identifier is used for ordering purposes and is not printed on the device package. Check with your Microchip Sales Office for package availability with the Tape and Reel option.

PRODUCT IDENTIFICATION SYSTEM (AUTOMOTIVE)

To order or obtain information, e.g., on pricing or delivery, refer to the factory or the listed sales office.

<u>PART NO.</u>	X ⁽¹⁾	-X	/XX	XXX ^(2,3)	
Device	Tape and Reel Option	Temperature Range	Package	Variant	
Device:	23LC1024:	1-Mbit, 2.5V - 5.5V, SPI Serial SRAM			
Tape and Reel:	Blank =	Standard packaging (tube)			
	T =	Tape and Reel ⁽¹⁾			
Temperature Range:	I =	-40°C to +85°C (AEC-Q100 Grade 3)			
	E =	-40°C to +125°C (AEC-Q100 Grade 1)			
Package:	SN =	Plastic SOIC (3.90 mm body), 8-lead			
	ST =	Plastic TSSOP (4.4 mm body), 8-lead			
Variant^(2,3):	VAO =	Standard Automotive			
	VXX =	Customer Specific Automotive			

Examples:

- a) 23LC1024-I/SNVAO
- b) 23LC1024T-I/SNVAO
- c) 23LC1024T-E/SNVAO
- d) 23LC1024-E/STVAO

Note 1: Tape and Reel identifier only appears in the catalog part number description. This identifier is used for ordering purposes and is not printed on the device package. Check with your Microchip Sales Office for package availability with the Tape and Reel option.

2: The VAO/VXX automotive variants have been designed, manufactured, tested and qualified in accordance with AEC-Q100 requirements for automotive applications.

3: For customers requesting a PPAP, a customer-specific part number will be generated and provided. A PPAP is not provided for VAO part numbers.

Note the following details of the code protection feature on Microchip products:

- Microchip products meet the specifications contained in their particular Microchip Data Sheet.
- Microchip believes that its family of products is secure when used in the intended manner, within operating specifications, and under normal conditions.
- Microchip values and aggressively protects its intellectual property rights. Attempts to breach the code protection features of Microchip product is strictly prohibited and may violate the Digital Millennium Copyright Act.
- Neither Microchip nor any other semiconductor manufacturer can guarantee the security of its code. Code protection does not mean that we are guaranteeing the product is "unbreakable" Code protection is constantly evolving. Microchip is committed to continuously improving the code protection features of our products.

This publication and the information herein may be used only with Microchip products, including to design, test, and integrate Microchip products with your application. Use of this information in any other manner violates these terms. Information regarding device applications is provided only for your convenience and may be superseded by updates. It is your responsibility to ensure that your application meets with your specifications. Contact your local Microchip sales office for additional support or, obtain additional support at <https://www.microchip.com/en-us/support/design-help/client-support-services>.

THIS INFORMATION IS PROVIDED BY MICROCHIP "AS IS". MICROCHIP MAKES NO REPRESENTATIONS OR WARRANTIES OF ANY KIND WHETHER EXPRESS OR IMPLIED, WRITTEN OR ORAL, STATUTORY OR OTHERWISE, RELATED TO THE INFORMATION INCLUDING BUT NOT LIMITED TO ANY IMPLIED WARRANTIES OF NON-INFRINGEMENT, MERCHANTABILITY, AND FITNESS FOR A PARTICULAR PURPOSE, OR WARRANTIES RELATED TO ITS CONDITION, QUALITY, OR PERFORMANCE.

IN NO EVENT WILL MICROCHIP BE LIABLE FOR ANY INDIRECT, SPECIAL, PUNITIVE, INCIDENTAL, OR CONSEQUENTIAL LOSS, DAMAGE, COST, OR EXPENSE OF ANY KIND WHATSOEVER RELATED TO THE INFORMATION OR ITS USE, HOWEVER CAUSED, EVEN IF MICROCHIP HAS BEEN ADVISED OF THE POSSIBILITY OR THE DAMAGES ARE FORESEEABLE. TO THE FULLEST EXTENT ALLOWED BY LAW, MICROCHIP'S TOTAL LIABILITY ON ALL CLAIMS IN ANY WAY RELATED TO THE INFORMATION OR ITS USE WILL NOT EXCEED THE AMOUNT OF FEES, IF ANY, THAT YOU HAVE PAID DIRECTLY TO MICROCHIP FOR THE INFORMATION.

Use of Microchip devices in life support and/or safety applications is entirely at the buyer's risk, and the buyer agrees to defend, indemnify and hold harmless Microchip from any and all damages, claims, suits, or expenses resulting from such use. No licenses are conveyed, implicitly or otherwise, under any Microchip intellectual property rights unless otherwise stated.

For information regarding Microchip's Quality Management Systems, please visit www.microchip.com/quality.

Trademarks

The Microchip name and logo, the Microchip logo, Adaptec, AVR, AVR logo, AVR Freaks, BesTime, BitCloud, CryptoMemory, CryptoRF, dsPIC, flexPWR, HELDO, IGLOO, JukeBlox, KeeLoq, Kleer, LANCheck, LinkMD, maXStylus, maXTouch, MediaLB, megaAVR, Microsemi, Microsemi logo, MOST, MOST logo, MPLAB, OptoLyzer, PIC, picoPower, PICSTART, PIC32 logo, PolarFire, Prochip Designer, QTouch, SAM-BA, SenGenuity, SpyNIC, SST, SST Logo, SuperFlash, Symmetricom, SyncServer, Tachyon, TimeSource, tinyAVR, UNI/O, Vectron, and XMEGA are registered trademarks of Microchip Technology Incorporated in the U.S.A. and other countries.

AgileSwitch, ClockWorks, The Embedded Control Solutions Company, EtherSynch, Flashtec, Hyper Speed Control, HyperLight Load, Libero, motorBench, mTouch, Powermite 3, Precision Edge, ProASIC, ProASIC Plus, ProASIC Plus logo, Quiet-Wire, SmartFusion, SyncWorld, TimeCesium, TimeHub, TimePictra, TimeProvider, and ZL are registered trademarks of Microchip Technology Incorporated in the U.S.A.

Adjacent Key Suppression, AKS, Analog-for-the-Digital Age, Any Capacitor, AnyIn, AnyOut, Augmented Switching, BlueSky, BodyCom, Clockstudio, CodeGuard, CryptoAuthentication, CryptoAutomotive, CryptoCompanion, CryptoController, dsPICDEM, dsPICDEM.net, Dynamic Average Matching, DAM, ECAN, Espresso T1S, EtherGREEN, EyeOpen, GridTime, IdealBridge, IGA, In-Circuit Serial Programming, ICSP, INICnet, Intelligent Paralleling, IntelliMOS, Inter-Chip Connectivity, JitterBlocker, Knob-on-Display, MarginLink, maxCrypto, maxView, memBrain, Mindi, MiWi, MPASM, MPF, MPLAB Certified logo, MPLIB, MPLINK, mSIC, MultiTRAK, NetDetach, Omniscient Code Generation, PICDEM, PICDEM.net, PICkit, PICtail, Power MOS IV, Power MOS 7, PowerSmart, PureSilicon, QMatrix, REAL ICE, Ripple Blocker, RTAX, RTG4, SAM-ICE, Serial Quad I/O, simpleMAP, SimpliPHY, SmartBuffer, SmartHLS, SMART-I.S., storClad, SQL, SuperSwitcher, SuperSwitcher II, Switchtec, SynchroPHY, Total Endurance, Trusted Time, TSHARC, Turing, USBCheck, VariSense, VectorBlox, VeriPHY, ViewSpan, WiperLock, XpressConnect, and ZENA are trademarks of Microchip Technology Incorporated in the U.S.A. and other countries.

SQTP is a service mark of Microchip Technology Incorporated in the U.S.A.

The Adaptec logo, Frequency on Demand, Silicon Storage Technology, and Symmcom are registered trademarks of Microchip Technology Inc. in other countries.

GestIC is a registered trademark of Microchip Technology Germany II GmbH & Co. KG, a subsidiary of Microchip Technology Inc., in other countries.

All other trademarks mentioned herein are property of their respective companies.

© 2023, Microchip Technology Incorporated and its subsidiaries.

All Rights Reserved.

ISBN: 978-1-6683-3044-9



MICROCHIP

Worldwide Sales and Service

AMERICAS

Corporate Office
2355 West Chandler Blvd.
Chandler, AZ 85224-6199
Tel: 480-792-7200
Fax: 480-792-7277
Technical Support:
<http://www.microchip.com/support>
Web Address:
www.microchip.com

Atlanta

Duluth, GA
Tel: 678-957-9614
Fax: 678-957-1455

Austin, TX

Tel: 512-257-3370

Boston

Westborough, MA
Tel: 774-760-0087
Fax: 774-760-0088

Chicago

Itasca, IL
Tel: 630-285-0071
Fax: 630-285-0075

Dallas

Addison, TX
Tel: 972-818-7423
Fax: 972-818-2924

Detroit

Novi, MI
Tel: 248-848-4000

Houston, TX

Tel: 281-894-5983

Indianapolis

Noblesville, IN
Tel: 317-773-8323
Fax: 317-773-5453
Tel: 317-536-2380

Los Angeles

Mission Viejo, CA
Tel: 949-462-9523
Fax: 949-462-9608
Tel: 951-273-7800

Raleigh, NC

Tel: 919-844-7510

New York, NY

Tel: 631-435-6000

San Jose, CA

Tel: 408-735-9110
Tel: 408-436-4270

Canada - Toronto

Tel: 905-695-1980
Fax: 905-695-2078

ASIA/PACIFIC

Australia - Sydney
Tel: 61-2-9868-6733

China - Beijing
Tel: 86-10-8569-7000

China - Chengdu
Tel: 86-28-8665-5511

China - Chongqing
Tel: 86-23-8980-9588

China - Dongguan
Tel: 86-769-8702-9880

China - Guangzhou
Tel: 86-20-8755-8029

China - Hangzhou
Tel: 86-571-8792-8115

China - Hong Kong SAR
Tel: 852-2943-5100

China - Nanjing
Tel: 86-25-8473-2460

China - Qingdao
Tel: 86-532-8502-7355

China - Shanghai
Tel: 86-21-3326-8000

China - Shenyang
Tel: 86-24-2334-2829

China - Shenzhen
Tel: 86-755-8864-2200

China - Suzhou
Tel: 86-186-6233-1526

China - Wuhan
Tel: 86-27-5980-5300

China - Xian
Tel: 86-29-8833-7252

China - Xiamen
Tel: 86-592-2388138

China - Zhuhai
Tel: 86-756-3210040

ASIA/PACIFIC

India - Bangalore
Tel: 91-80-3090-4444

India - New Delhi
Tel: 91-11-4160-8631

India - Pune
Tel: 91-20-4121-0141

Japan - Osaka
Tel: 81-6-6152-7160

Japan - Tokyo
Tel: 81-3-6880-3770

Korea - Daegu
Tel: 82-53-744-4301

Korea - Seoul
Tel: 82-2-554-7200

Malaysia - Kuala Lumpur
Tel: 60-3-7651-7906

Malaysia - Penang
Tel: 60-4-227-8870

Philippines - Manila
Tel: 63-2-634-9065

Singapore
Tel: 65-6334-8870

Taiwan - Hsin Chu
Tel: 886-3-577-8366

Taiwan - Kaohsiung
Tel: 886-7-213-7830

Taiwan - Taipei
Tel: 886-2-2508-8600

Thailand - Bangkok
Tel: 66-2-694-1351

Vietnam - Ho Chi Minh
Tel: 84-28-5448-2100

EUROPE

Austria - Wels
Tel: 43-7242-2244-39
Fax: 43-7242-2244-393

Denmark - Copenhagen
Tel: 45-4485-5910
Fax: 45-4485-2829

Finland - Espoo
Tel: 358-9-4520-820

France - Paris
Tel: 33-1-69-53-63-20
Fax: 33-1-69-30-90-79

Germany - Garching
Tel: 49-8931-9700

Germany - Haan
Tel: 49-2129-3766400

Germany - Heilbronn
Tel: 49-7131-72400

Germany - Karlsruhe
Tel: 49-721-625370

Germany - Munich
Tel: 49-89-627-144-0
Fax: 49-89-627-144-44

Germany - Rosenheim
Tel: 49-8031-354-560

Israel - Ra'anana
Tel: 972-9-744-7705

Italy - Milan
Tel: 39-0331-742611
Fax: 39-0331-466781

Italy - Padova
Tel: 39-049-7625286

Netherlands - Drunen
Tel: 31-416-690399
Fax: 31-416-690340

Norway - Trondheim
Tel: 47-7288-4388

Poland - Warsaw
Tel: 48-22-3325737

Romania - Bucharest
Tel: 40-21-407-87-50

Spain - Madrid
Tel: 34-91-708-08-90
Fax: 34-91-708-08-91

Sweden - Gothenberg
Tel: 46-31-704-60-40

Sweden - Stockholm
Tel: 46-8-5090-4654

UK - Wokingham
Tel: 44-118-921-5800
Fax: 44-118-921-5820