

High-Voltage Input Integrated Switch Step-Down Regulator

Features

- Up to 96% Typical Efficiency
- Input Voltage Range:
 - 4.0V to 30V (**MCP16301**)
 - 4.7V to 36V (**MCP16301H**)
- Output Voltage Range: 2.0V to 15V
- 2% Output Voltage Accuracy
- Passes Automotive AEC-Q100 Reliability Testing
- Integrated N-Channel Buck Switch: 460 mΩ
- Minimum 600 mA Output Current Over All Input Voltage Range (See [Figure 2-6](#) for Maximum Output Current vs. V_{IN}):
 - Up to 1A output current at 3.3V, 5V and 12V V_{OUT} , SOT-23 package at +25°C ambient temperature
- 500 kHz Fixed Frequency
- Adjustable Output Voltage
- Low Device Shutdown Current
- Peak Current Mode Control
- Internal Soft-Start
- Internal Compensation
- Stable with Ceramic Capacitors
- Cycle-by-Cycle Peak Current Limit
- Undervoltage Lockout (UVLO): 3.5V
- Overtemperature Protection
- Available Package: SOT-23-6

Applications

- PIC[®] Microcontroller and dsPIC[®] Digital Signal Controller Bias Supply
- 24V Industrial Input DC-DC Conversion
- Set-Top Boxes
- DSL Cable Modems
- Automotive
- Wall Cube Regulation
- SLA Battery-Powered Devices
- AC-DC Digital Control Power Source
- Power Meters
- D² Package Linear Regulator Replacement
 - See [Figure 5-2](#)
- Consumer
- Medical and Health Care
- Distributed Power Supplies

General Description

The MCP16301/H devices are highly integrated, high-efficiency, fixed-frequency, step-down DC-DC converters in a popular 6-pin SOT-23 package, that operate from input voltage sources up to 36V. Integrated features include a high-side switch, fixed-frequency peak current mode control, internal compensation, peak current limit and overtemperature protection. Only a few external components are necessary to develop a complete step-down DC-DC converter power supply.

High converter efficiency is achieved by integrating the current-limited, low-resistance, high-speed N-Channel MOSFET and associated drive circuitry. High switching frequency minimizes the size of external filtering components, resulting in a small solution size.

The MCP16301/H devices can supply 600 mA of continuous current while regulating the output voltage from 2.0V to 15V. An integrated, high-performance peak current mode architecture keeps the output voltage tightly regulated, even during input voltage steps and output current transient conditions that are common in power systems.

The EN input is used to turn the device on and off. While turned off, only a few micro amps of current are consumed from the input for power shedding and load distribution applications.

Output voltage is set with an external resistor divider. The MCP16301/H devices are offered in a space-saving SOT-23-6 surface mount package.

Package Type

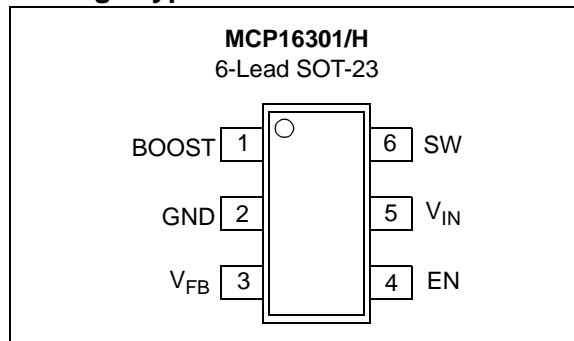

MCP16301/H

Typical Applications

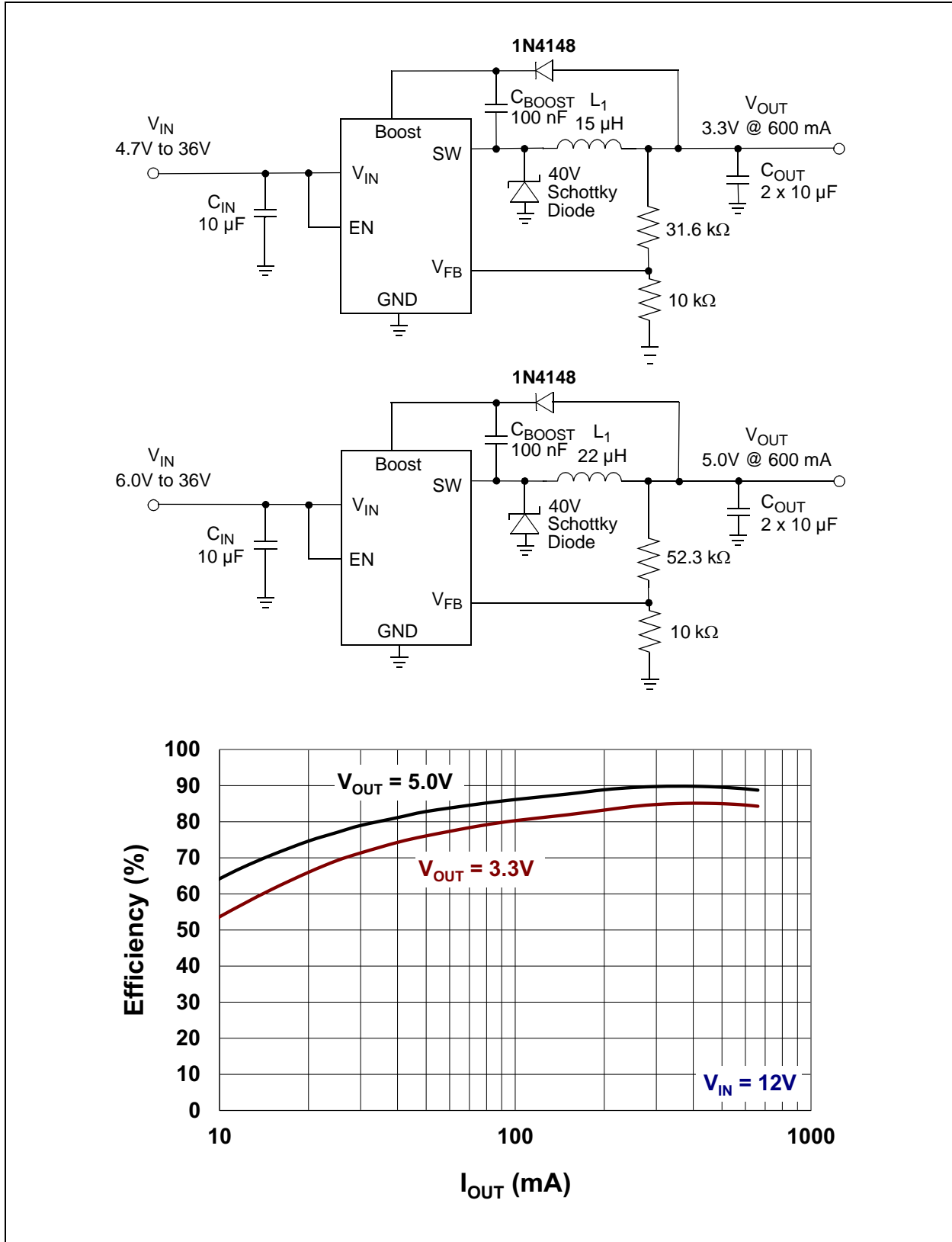

1.0 ELECTRICAL CHARACTERISTICS

Absolute Maximum Ratings †

$V_{IN, SW}$	-0.5V to 40V
BOOST – GND.....	-0.5V to 46V
BOOST – SW Voltage.....	-0.5V to 6.0V
V_{FB} Voltage.....	-0.5V to 6.0V
EN Voltage	-0.5V to ($V_{IN} + 0.3V$)
Output Short-Circuit Current	Continuous
Power Dissipation	Internally Limited
Storage Temperature	-65°C to +150°C
Ambient Temperature with Power Applied ...	-40°C to +125°C
Operating Junction Temperature.....	-40°C to +150°C
ESD Protection On All Pins:	
HBM.....	3 kV
MM.....	200V

† **Notice:** Stresses above those listed under “Maximum Ratings” may cause permanent damage to the device. This is a stress rating only and functional operation of the device at those or any other conditions above those indicated in the operational sections of this specification is not intended. Exposure to maximum rating conditions for extended periods may affect device reliability.

DC CHARACTERISTICS

Electrical Characteristics: Unless otherwise indicated, $T_A = +25^\circ\text{C}$, $V_{IN} = V_{EN} = 12V$, $V_{BOOST} - V_{SW} = 3.3V$, $V_{OUT} = 3.3V$, $I_{OUT} = 100\text{ mA}$, $L = 15\ \mu\text{H}$, $C_{OUT} = C_{IN} = 2 \times 10\ \mu\text{F}$ X7R ceramic capacitors.
Boldface specifications apply over the T_A range of -40°C to $+125^\circ\text{C}$.

Parameters	Sym.	Min.	Typ.	Max.	Units	Conditions
Input Voltage	V_{IN}	4	—	30	V	Note 1 (MCP16301)
		4.7	—	36	V	Note 1 (MCP16301H)
Feedback Voltage	V_{FB}	0.784	0.800	0.816	V	
Output Voltage Adjust Range	V_{OUT}	2.0	—	15.0	V	Note 2
Feedback Voltage Line Regulation	$(\Delta V_{FB}/V_{FB})/\Delta V_{IN}$	—	0.01	0.1	%/V	$V_{IN} = 12V$ to $30V$
Feedback Input Bias Current	I_{FB}	-250	± 10	+250	nA	
Undervoltage Lockout Start	$UVLO_{START}$	—	3.5	4.0	V	V_{IN} Rising (MCP16301)
		—	3.5	4.7	V	V_{IN} Rising (MCP16301H)
Undervoltage Lockout Stop	$UVLO_{STOP}$	2.4	3.0	—	V	V_{IN} Falling
Undervoltage Lockout Hysteresis	$UVLO_{HYS}$	—	0.5	—	V	
Switching Frequency	f_{SW}	425	500	550	kHz	$I_{OUT} = 200\text{ mA}$
Maximum Duty Cycle	DC_{MAX}	90	95	—	%	$V_{IN} = 5V$; $V_{FB} = 0.7V$; $I_{OUT} = 100\text{ mA}$
Minimum Duty Cycle	DC_{MIN}	—	1	—	%	
NMOS Switch On Resistance	$R_{DS(ON)}$	—	0.46	—	Ω	$V_{BOOST} - V_{SW} = 3.3V$
NMOS Switch Current Limit	$I_{N(MAX)}$	—	1.3	—	A	$V_{BOOST} - V_{SW} = 3.3V$
Quiescent Current	I_Q	—	2	7.5	mA	$V_{BOOST} = 3.3V$; Note 3
Quiescent Current - Shutdown	I_Q	—	7	10	μA	$V_{OUT} = EN = 0V$
Maximum Output Current	I_{OUT}	600	—	—	mA	Note 1
EN Input Logic High	V_{IH}	1.4	—	—	V	
EN Input Logic Low	V_{IL}	—	—	0.4	V	
EN Input Leakage Current	I_{ENLK}	—	0.05	1.0	μA	$V_{EN} = 12V$

Note 1: The input voltage should be $>$ output voltage + headroom voltage; higher load currents increase the input voltage necessary for regulation. See characterization graphs for typical input to output operating voltage range and $UVLO_{START}$ and $UVLO_{STOP}$ limits.

2: For $V_{IN} < V_{OUT}$, V_{OUT} will not remain in regulation.

3: V_{BOOST} supply is derived from V_{OUT} .

MCP16301/H

DC CHARACTERISTICS (CONTINUED)

Electrical Characteristics: Unless otherwise indicated, $T_A = +25^\circ\text{C}$, $V_{IN} = V_{EN} = 12\text{V}$, $V_{BOOST} - V_{SW} = 3.3\text{V}$, $V_{OUT} = 3.3\text{V}$, $I_{OUT} = 100\text{ mA}$, $L = 15\ \mu\text{H}$, $C_{OUT} = C_{IN} = 2 \times 10\ \mu\text{F}$ X7R ceramic capacitors.
Boldface specifications apply over the T_A range of -40°C to $+125^\circ\text{C}$.

Parameters	Sym.	Min.	Typ.	Max.	Units	Conditions
Soft-Start Time	t_{SS}	—	300	—	μs	EN Low to High, 90% of V_{OUT}
Thermal Shutdown Die Temperature	T_{SD}	—	150	—	$^\circ\text{C}$	
Die Temperature Hysteresis	T_{SDHYS}	—	30	—	$^\circ\text{C}$	

- Note 1:** The input voltage should be $>$ output voltage + headroom voltage; higher load currents increase the input voltage necessary for regulation. See characterization graphs for typical input to output operating voltage range and $UVLO_{START}$ and $UVLO_{STOP}$ limits.
- 2:** For $V_{IN} < V_{OUT}$, V_{OUT} will not remain in regulation.
- 3:** V_{BOOST} supply is derived from V_{OUT} .

TEMPERATURE SPECIFICATIONS

Electrical Specifications: Unless otherwise indicated, $T_A = +25^\circ\text{C}$, $V_{IN} = V_{EN} = 12\text{V}$, $V_{BOOST} - V_{SW} = 3.3\text{V}$, $V_{OUT} = 3.3\text{V}$

Parameters	Sym.	Min.	Typ.	Max.	Units	Conditions
Temperature Ranges						
Operating Junction Temperature Range	T_J	-40	—	+125	$^\circ\text{C}$	Steady State
Storage Temperature Range	T_A	-65	—	+150	$^\circ\text{C}$	
Maximum Junction Temperature	T_J	—	—	+150	$^\circ\text{C}$	Transient
Package Thermal Resistances						
Thermal Resistance, 6L-SOT-23	θ_{JA}	—	190.5	—	$^\circ\text{C/W}$	EIA/JESD51-3 Standard

2.0 TYPICAL PERFORMANCE CURVES

Note: The graphs and tables provided following this note are a statistical summary based on a limited number of samples and are provided for informational purposes only. The performance characteristics listed herein are not tested or guaranteed. In some graphs or tables, the data presented may be outside the specified operating range (e.g., outside specified power supply range) and therefore outside the warranted range.

Note: Unless otherwise indicated, $V_{IN} = EN = 12V$, $C_{OUT} = C_{IN} = 2 \times 10 \mu F$, $L = 15 \mu H$, $V_{OUT} = 3.3V$, $I_{LOAD} = 200 \text{ mA}$, $T_A = +25^\circ C$.

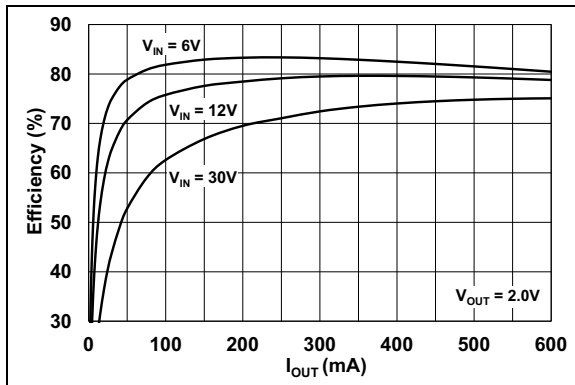

FIGURE 2-1: 2.0V V_{OUT} Efficiency vs. I_{OUT} .

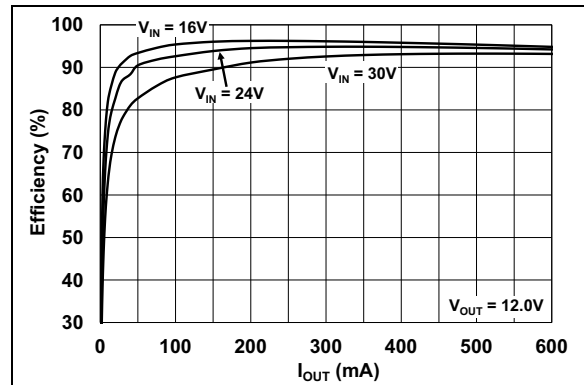

FIGURE 2-4: 12V V_{OUT} Efficiency vs. I_{OUT} .

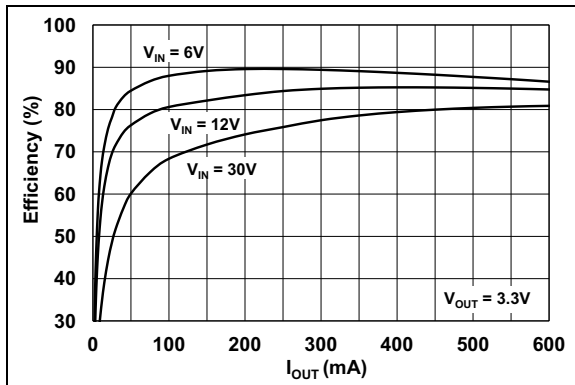

FIGURE 2-2: 3.3V V_{OUT} Efficiency vs. I_{OUT} .

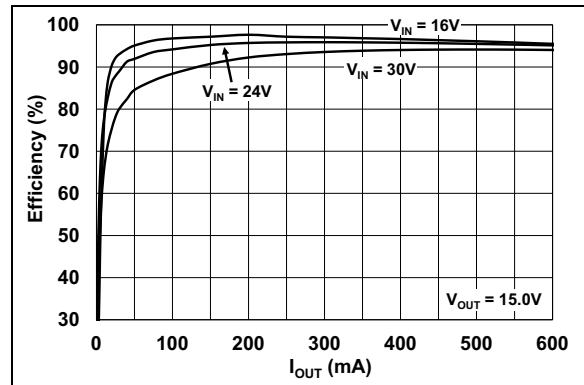

FIGURE 2-5: 15V V_{OUT} Efficiency vs. I_{OUT} .

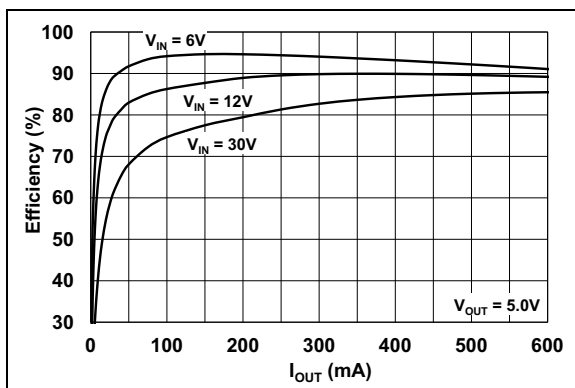

FIGURE 2-3: 5.0V V_{OUT} Efficiency vs. I_{OUT} .

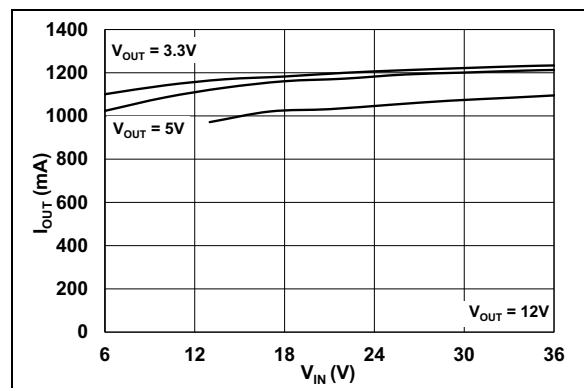

FIGURE 2-6: Maximum Output Current vs. V_{IN} .

MCP16301/H

Note: Unless otherwise indicated, $V_{IN} = EN = 12V$, $C_{OUT} = C_{IN} = 2 \times 10 \mu F$, $L = 15 \mu H$, $V_{OUT} = 3.3V$, $I_{LOAD} = 200 \text{ mA}$, $T_A = +25^\circ C$.

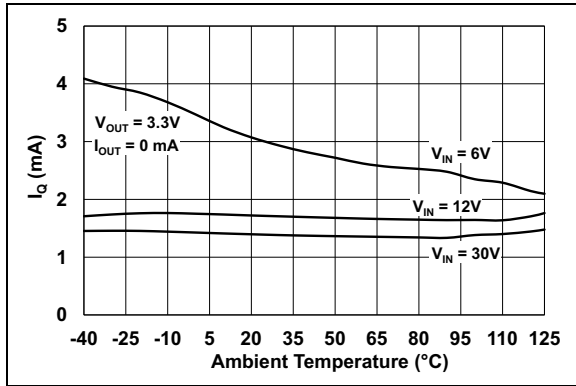

FIGURE 2-7: Input Quiescent Current vs. Temperature.

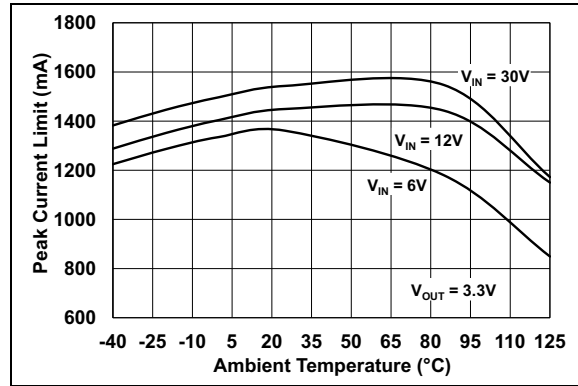

FIGURE 2-10: Peak Current Limit vs. Temperature; $V_{OUT} = 3.3V$.

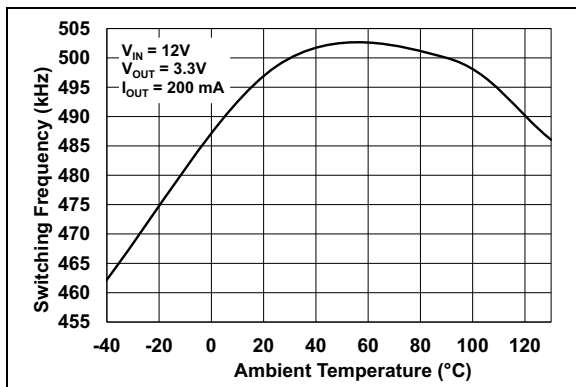

FIGURE 2-8: Switching Frequency vs. Temperature; $V_{OUT} = 3.3V$.

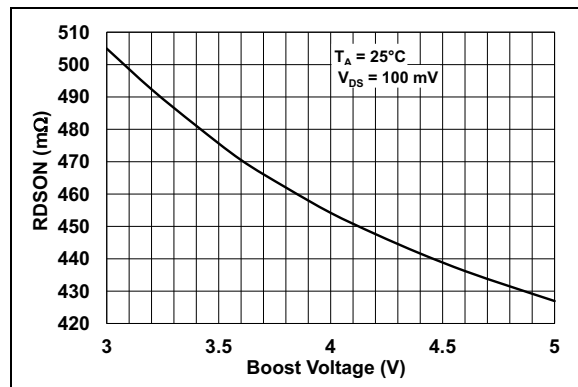

FIGURE 2-11: Switch $R_{DS(on)}$ vs. V_{BOOST} .

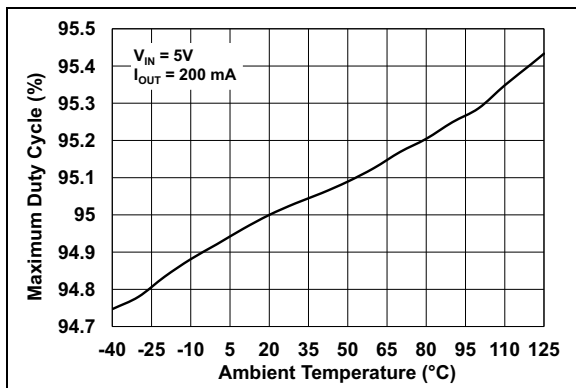

FIGURE 2-9: Maximum Duty Cycle vs. Ambient Temperature; $V_{OUT} = 5.0V$.

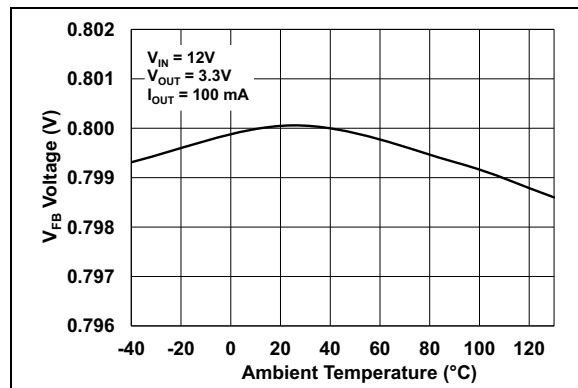

FIGURE 2-12: V_{FB} vs. Temperature; $V_{OUT} = 3.3V$.

Note: Unless otherwise indicated, $V_{IN} = EN = 12V$, $C_{OUT} = C_{IN} = 2 \times 10 \mu F$, $L = 15 \mu H$, $V_{OUT} = 3.3V$, $I_{LOAD} = 200 \text{ mA}$, $T_A = +25^\circ C$.

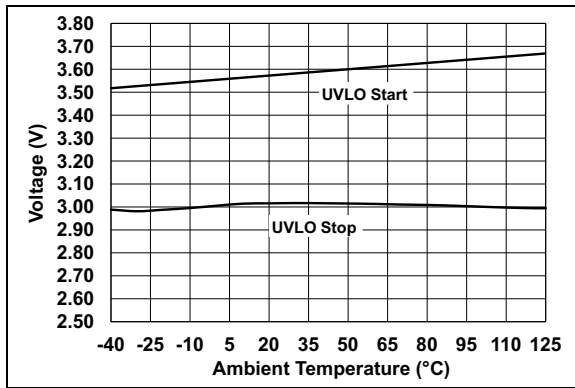

FIGURE 2-13: Undervoltage Lockout vs. Temperature.

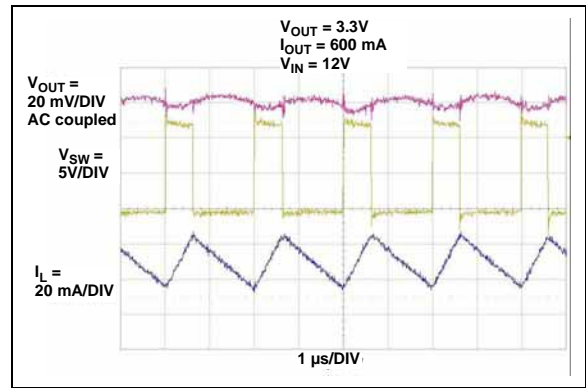

FIGURE 2-16: Heavy Load Switching Waveforms.

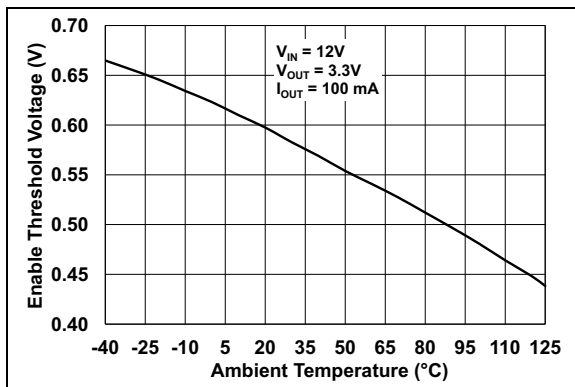

FIGURE 2-14: EN Threshold Voltage vs. Temperature.

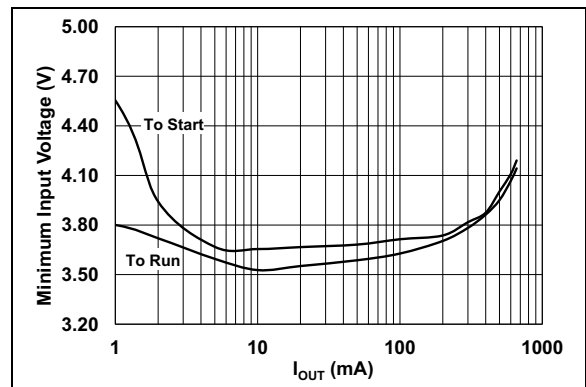

FIGURE 2-17: Typical Minimum Input Voltage vs. Output Current.

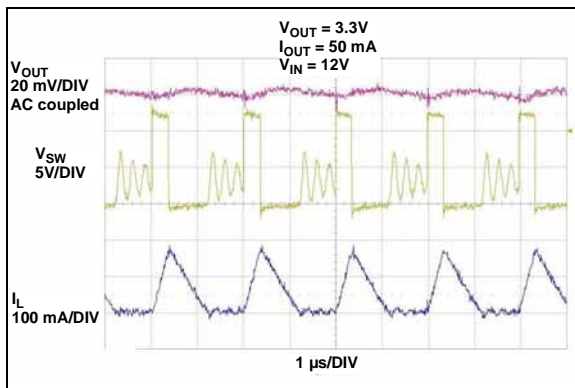

FIGURE 2-15: Light Load Switching Waveforms.

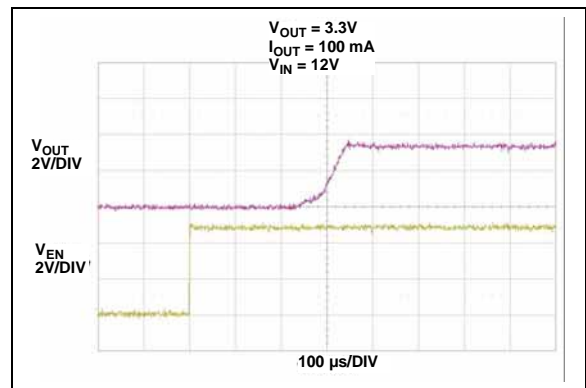

FIGURE 2-18: Start-Up From Enable.

MCP16301/H

Note: Unless otherwise indicated, $V_{IN} = EN = 12V$, $C_{OUT} = C_{IN} = 2 \times 10 \mu F$, $L = 15 \mu H$, $V_{OUT} = 3.3V$, $I_{LOAD} = 200 \text{ mA}$, $T_A = +25^\circ C$.

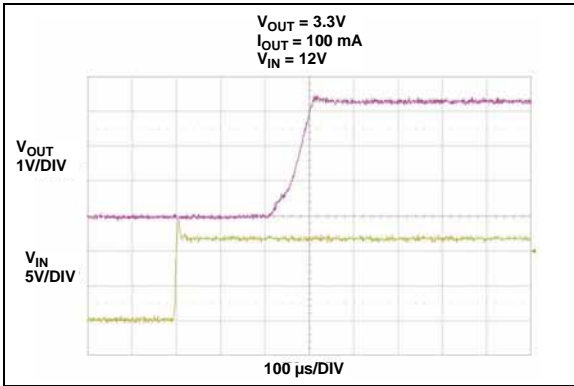

FIGURE 2-19: Start-Up from V_{IN} .

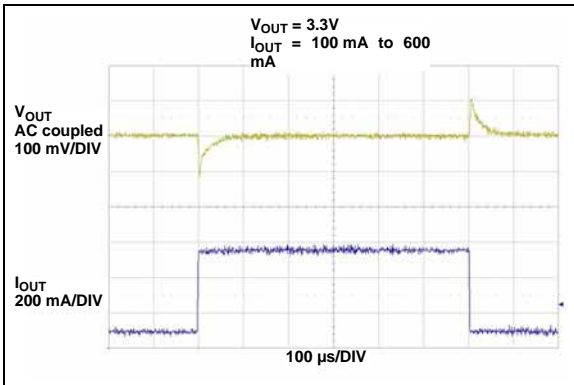

FIGURE 2-20: Load Transient Response.

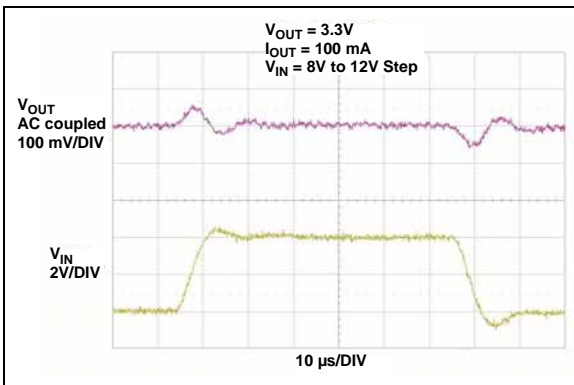

FIGURE 2-21: Line Transient Response.

3.0 PIN DESCRIPTIONS

The descriptions of the pins are listed in [Table 3-1](#).

TABLE 3-1: PIN FUNCTION TABLE

MCP16301/H SOT-23	Symbol	Description
1	BOOST	Boost voltage that drives the internal NMOS control switch. A bootstrap capacitor is connected between the BOOST and SW pins.
2	GND	Ground pin.
3	V _{FB}	Output voltage feedback pin. Connect V _{FB} to an external resistor divider to set the output voltage.
4	EN	Enable pin. Logic high enables the operation. Do not allow this pin to float.
5	V _{IN}	Input supply voltage pin for power and internal biasing.
6	SW	Output switch node. This pin connects to the inductor, the freewheeling diode and the bootstrap capacitor.

3.1 Boost Pin (BOOST)

The high side of the floating supply, used to turn the integrated N-Channel MOSFET on and off, is connected to the boost pin.

3.2 Ground Pin (GND)

The ground or return pin is used for circuit ground connection. The length of the trace from the input capacitor return, output capacitor return and GND pin should be made as short as possible, in order to minimize the noise on the GND pin.

3.3 Feedback Voltage Pin (V_{FB})

The V_{FB} pin is used to provide output voltage regulation by using a resistor divider. The V_{FB} voltage will be 0.800V typical, with the output voltage in regulation.

3.4 Enable Pin (EN)

The EN pin is a logic-level input used to enable or disable device switching and to lower the quiescent current while disabled. A logic high (> 1.4V) will enable the regulator's output; a logic low (< 0.4V) will ensure that the regulator is disabled.

3.5 Power Supply Input Voltage Pin (V_{IN})

Connect the input voltage source to V_{IN}. The input source should be decoupled to GND with a 4.7 μF (up to 20 μF) capacitor, depending on the impedance of the source and the output current. The input capacitor provides AC current for the power switch and a stable voltage source for the internal device power. This capacitor should be connected as close as possible to the V_{IN} and GND pins. For light load applications, a 1 μF X7R (or X5R, for limited temperature range, -40 to +85°C) ceramic capacitor can be used.

3.6 Switch Pin (SW)

The Switch Node pin is connected internally to the N-Channel switch and externally to the SW node consisting of the inductor and Schottky diode. The SW node can rise very fast, as a result of the internal switch turning on. The external Schottky diode should be connected close to the SW node and GND.

MCP16301/H

NOTES:

4.0 DETAILED DESCRIPTION

4.1 Device Overview

The MCP16301/H devices are high-input voltage step-down regulators, capable of supplying 600 mA to a regulated output voltage from 2.0V to 15V. Internally, the trimmed 500 kHz oscillator provides a fixed frequency, while the peak current mode control architecture varies the duty cycle for output voltage regulation. An internal floating driver is used to turn the high-side integrated N-Channel MOSFET on and off. The power for this driver is derived from an external boost capacitor whose energy is supplied from a fixed voltage ranging from 3.0V to 5.5V, typically the input or output voltage of the converter. For applications with an output voltage outside of this range, such as 12V, the boost capacitor bias can be derived from the output, using a simple Zener diode regulator.

4.1.1 INTERNAL REFERENCE VOLTAGE (V_{REF})

An integrated precise 0.8V reference combined with an external resistor divider sets the desired converter's output voltage. The resistor divider range can vary without affecting the control system gain. High-value resistors consume less current, but are more susceptible to noise.

4.1.2 INTERNAL COMPENSATION

All control system components necessary for stable operation over the entire device operating range are integrated, including the error amplifier and inductor current slope compensation. To add the proper amount of slope compensation, the inductor value changes along with the output voltage (see [Table 5-1](#)).

4.1.3 EXTERNAL COMPONENTS

External components consist of:

- input capacitor
- output filter (inductor and capacitor)
- freewheeling diode
- boost capacitor
- boost blocking diode
- resistor divider

The selection of the external inductor, output capacitor, input capacitor and freewheeling diode is dependent upon the output voltage and the maximum output current.

4.1.4 ENABLE INPUT

Enable input (EN), is used to enable and disable the device. If disabled, the MCP16301/H devices consume a minimal amount of current from the input. Once enabled, the internal soft start controls the output voltage rate of rise, preventing high-inrush current and output voltage overshoot.

4.1.5 SOFT START

The internal reference voltage rate of rise is controlled during start-up, minimizing the output voltage overshoot and the inrush current.

4.1.6 UNDERVOLTAGE LOCKOUT

An integrated Undervoltage Lockout (UVLO) prevents the converter from starting until the input voltage is high enough for normal operation. The converter will typically start at 3.5V and operate down to 3.0V. Hysteresis is added to prevent starting and stopping during start-up, as a result of loading the input voltage source.

4.1.7 OVERTEMPERATURE PROTECTION

Overtemperature protection limits the silicon die temperature to +150°C by turning the converter off. The normal switching resumes at +120°C.

MCP16301/H

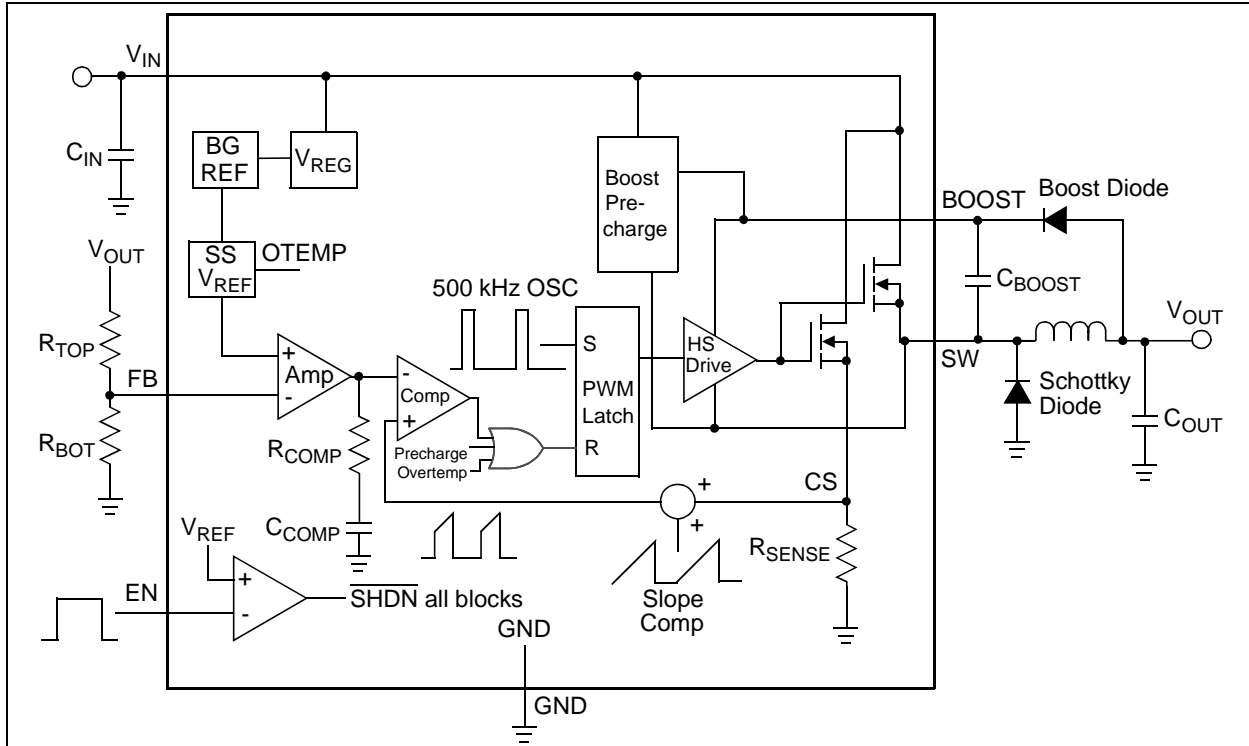

FIGURE 4-1: MCP16301/H Block Diagram.

4.2 Functional Description

4.2.1 STEP-DOWN OR BUCK CONVERTER

The MCP16301/H devices are non-synchronous step-down or buck converters, capable of stepping input voltages ranging from 4V to 30V (MCP16301) or 36V (MCP16301H) down to 2.0V to 15V, for $V_{IN} > V_{OUT}$.

The integrated high-side switch is used to chop or modulate the input voltage using a controlled duty cycle for output voltage regulation. High efficiency is achieved by using low-resistance integrated switch, low forward drop diode (Schottky rectifier), low equivalent series resistance (ESR) capacitors and low DC impedance (DCR) inductor. When the switch is turned on, a DC voltage is applied to the inductor ($V_{IN} - V_{OUT}$), resulting in a positive linear ramp of inductor current. When the switch turns off, the applied inductor voltage is equal to $-V_{OUT}$, resulting in a negative linear ramp of inductor current (ignoring the forward drop of the Schottky diode).

For steady-state, continuous inductor current operation, the positive inductor current slope must be identical to the negative current slope. While operating in steady state, the switch duty cycle must be equal to the relationship of V_{OUT}/V_{IN} for constant output voltage regulation, under the condition that the inductor current is continuous or never reaches zero. For discontinuous inductor current operation, the steady-state duty cycle will be less than V_{OUT}/V_{IN} to maintain voltage

regulation. The average of the chopped input voltage or SW node voltage is equal to the output voltage, while the average of the inductor current is equal to the output current.

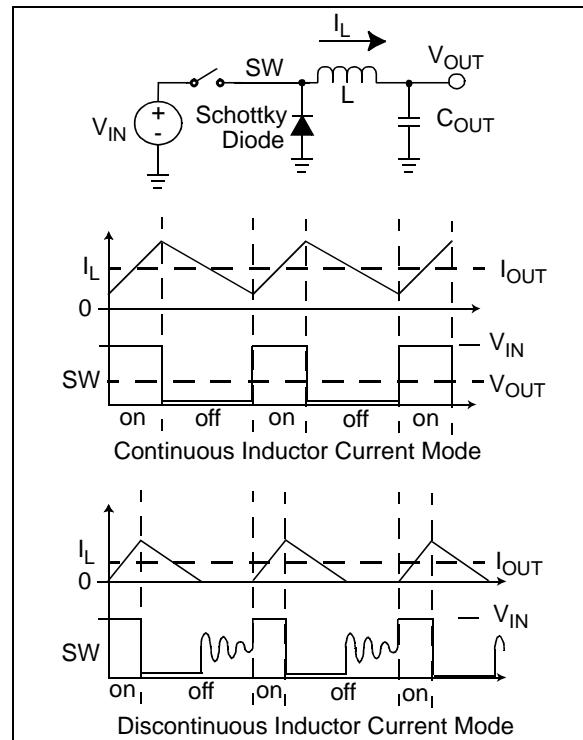

FIGURE 4-2: Step-Down Converter.

4.2.2 PEAK CURRENT MODE CONTROL

The MCP16301/H devices integrate a Peak Current Mode Control architecture, resulting in superior AC regulation while minimizing the number of voltage loop compensation components and their size, for integration. Peak Current Mode Control takes a small portion of the inductor current, replicates it, and compares this replicated current sense signal to the output of the integrated error voltage. In practice, the inductor current and the internal switch current are equal during the switch-on time. By adding this peak current sense to the system control, the step-down power train system is reduced from a 2nd order to a 1st order. This reduces the system complexity and increases its dynamic performance.

For Pulse-Width Modulation (PWM) duty cycles that exceed 50%, the control system can become bimodal where a wide pulse followed by a short pulse repeats instead of the desired fixed pulse width. To prevent this mode of operation, an internal compensating ramp is added to the current information, as shown in [Figure 4-1](#).

4.2.3 PULSE-WIDTH MODULATION (PWM)

The internal oscillator periodically starts the switching period, which, for MCP16301, occurs every 2 μ s (or with a frequency of 500 kHz). With the integrated switch turned on, the inductor current ramps up until the sum of the current sense and slope compensation ramp exceeds the integrated error amplifier output. The error amplifier output slews up or down to increase or decrease the inductor peak current feeding into the output LC filter. If the regulated output voltage is lower than its target, the inverting error amplifier output rises. This results in an increase in the inductor current to correct the errors in the output voltage.

The fixed-frequency duty cycle is terminated when the sensed inductor peak current, summed with the internal slope compensation, exceeds the output voltage of the error amplifier. The PWM latch is reset by turning off the internal switch and prevents it from turning on until the beginning of the next cycle. An overtemperature signal, or boost capacitor undervoltage, can also reset the PWM latch to asynchronously terminate the cycle.

4.2.4 HIGH-SIDE DRIVE

The MCP16301/H devices feature an integrated high-side N-Channel MOSFET for high-efficiency step-down power conversion; an N-Channel MOSFET is preferred for its low resistance and size (instead of a P-Channel MOSFET). The N-Channel MOSFET gate must be driven above its source to fully turn on the transistor. Therefore, a gate-drive voltage above the input is necessary to turn on the high-side N-Channel. The high-side drive voltage should be between 3.0V and 5.5V; the N-Channel source is connected to the inductor and Schottky diode, or switch node.

When the switch is off, the inductor current flows through the Schottky diode, providing a path to recharge the boost capacitor from the boost voltage source: typically, the output voltage for 3.0V to 5.0V output applications. A boost-blocking diode is used to prevent current flow from the boost capacitor back into the output during the internal switch-on time. Prior to start-up, the boost cap has no stored charge to drive the switch; an internal regulator is used to precharge the boost cap.

Once precharged, the switch is turned on and the inductor current flows. When the switch turns off, the inductor current free-wheels through the Schottky diode, providing a path to recharge the boost capacitor. Worst-case conditions for recharge occur when the switch turns on for a very short duty cycle at light load, limiting the inductor current ramp. In this case, there is a small amount of time for the boost capacitor to recharge. For high input voltages there is enough pre-charge current to replenish the boost capacitor charge. For input voltages above 5.5V typical, the MCP16301/H devices will regulate the output voltage with no load. After starting, the MCP16301/H devices will regulate the output voltage until the input voltage decreases below 4V. See [Figure 2-17](#) for device range of operation over input voltage, output voltage and load.

4.2.5 ALTERNATIVE BOOST BIAS

For 3.0V to 5.0V output voltage applications, the boost supply is typically the output voltage. For applications with the output voltage lower than 3V or higher than 5V, an alternative boost supply can be used.

Alternative boost supplies can be directly used from the input, input derived, output derived or an auxiliary system voltage.

For low voltage output applications with unregulated input voltage, a shunt regulator derived from the input can be used to obtain the boost supply. For applications with high output voltage or regulated high input voltage, a series regulator can be used to derive the boost supply.

MCP16301/H

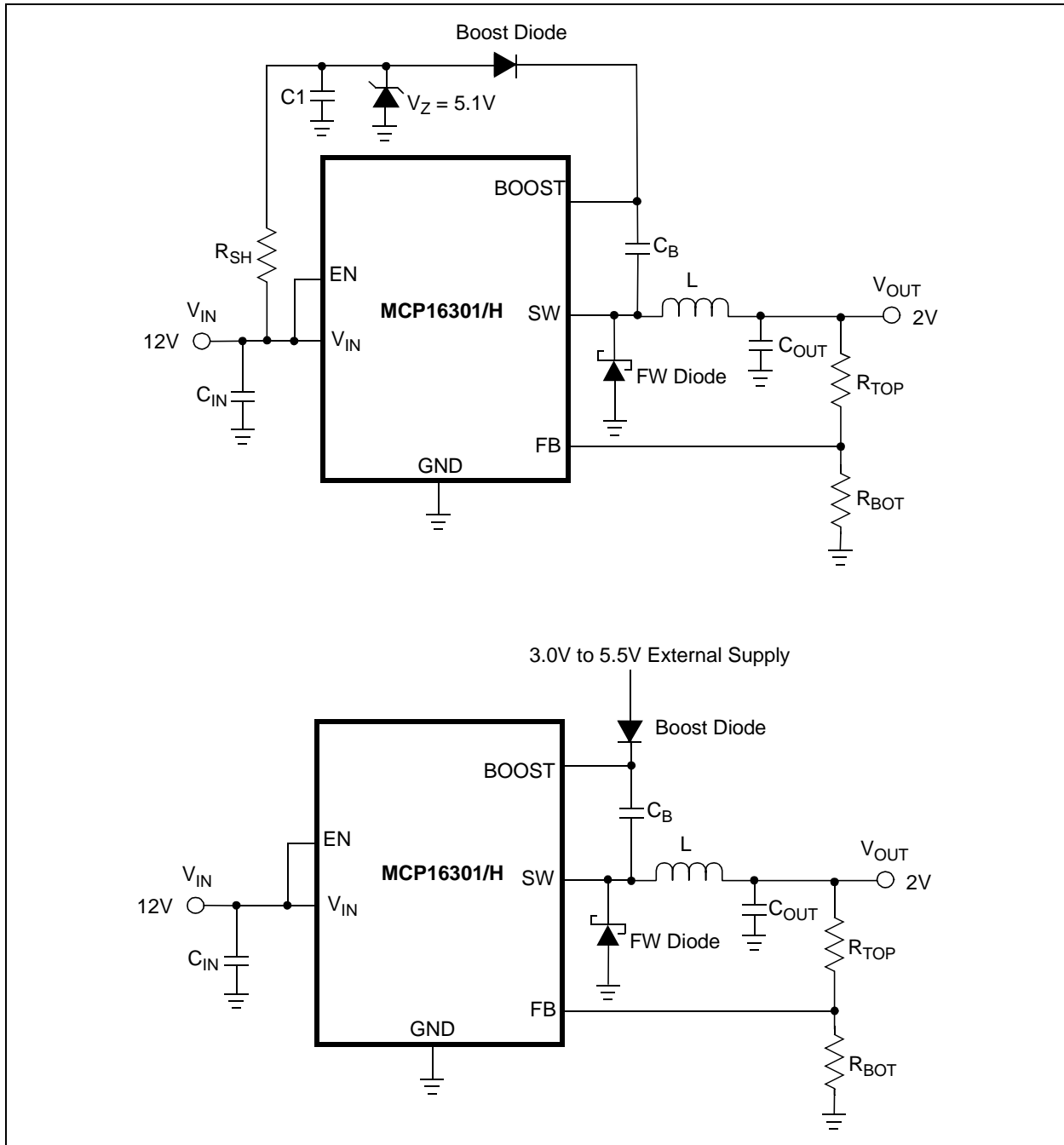

FIGURE 4-3: MCP16301/H Shunt and External Boost Supply.

Shunt Boost Supply Regulation is used for low-output voltage converters operating from a wide ranging input source. A regulated 3.0V to 5.5V supply is needed to provide high-side drive bias. The shunt uses a Zener diode to clamp the voltage within the 3.0V to 5.5V range using the R_{SH} resistor shown in [Figure 4-3](#).

To calculate the R_{SH} resistor value, the boost drive current needs to be estimated first using [Equation 4-1](#).

I_{BOOST_TYP} for 3.3V Boost Supply = 0.6 mA

I_{BOOST_TYP} for 5.0V Boost Supply = 0.8 mA

EQUATION 4-1: BOOST CURRENT

$$I_{BOOST} = I_{BOOST_TYP} \times 1.5 \text{ mA}$$

To calculate the R_{SH} resistor value, the maximum I_{BOOST} and I_Z currents are used at the minimum input voltage (Equation 4-2).

EQUATION 4-2: SHUNT RESISTANCE

$$R_{SH} = \frac{V_{INMIN} - V_Z}{I_{Boost} + I_Z}$$

V_Z and I_Z can be found on the Zener diode manufacturer's data sheet. Typically, $I_Z = 1 \text{ mA}$.

Series regulator applications use a Zener diode to drop the excess voltage. The series regulator bias source can be input or output voltage derived, as shown in Figure 4-4. For proper circuit operation, the boost supply must remain between 3.0V and 5.5V at all times.

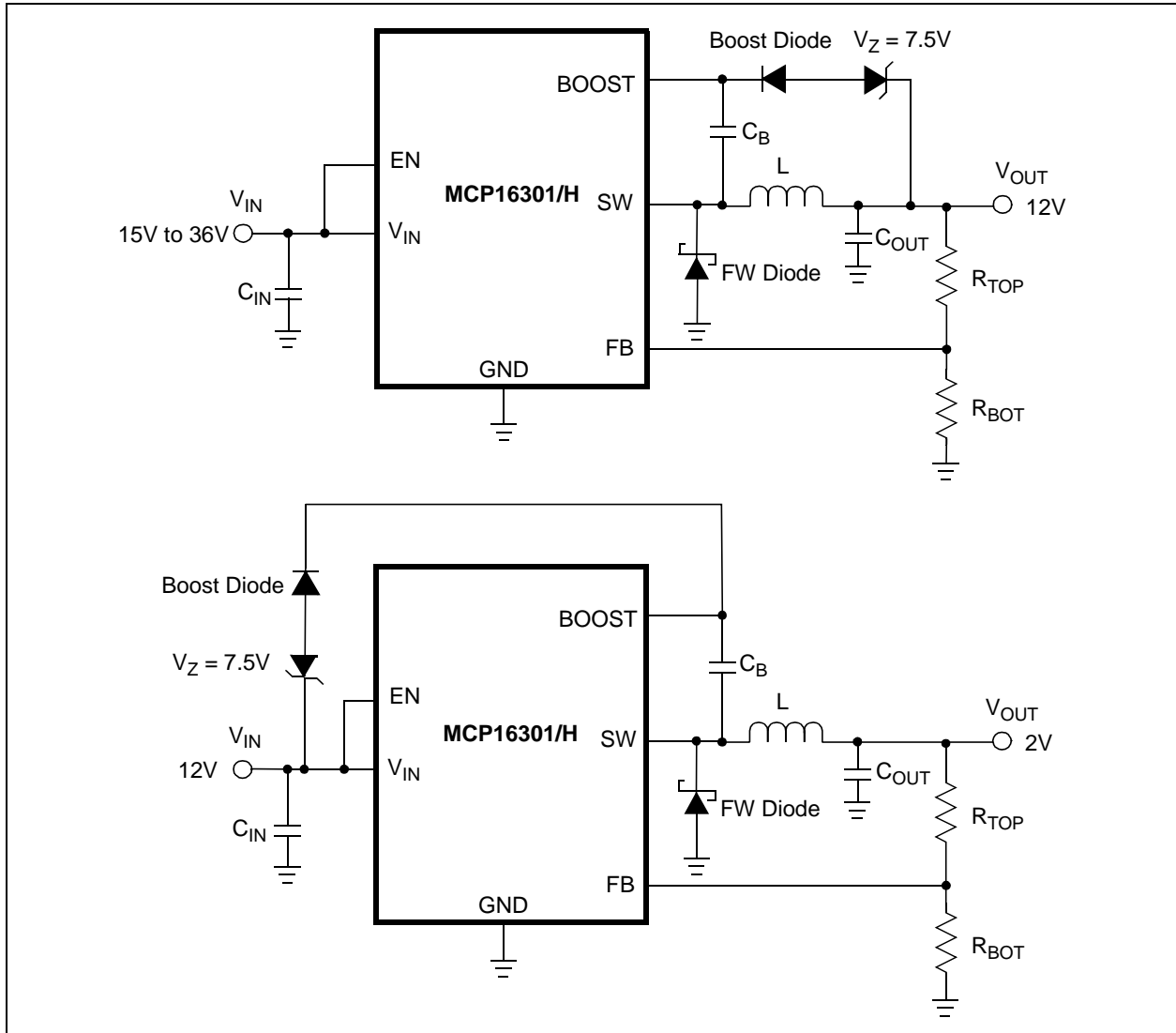

FIGURE 4-4: MCP16301/H Series Regulator Boost Supply.

MCP16301/H

NOTES:

5.0 APPLICATION INFORMATION

5.1 Typical Applications

The MCP16301/H step-down converters operate over a wide input voltage range, up to 36V maximum. Typical applications include generating a bias or V_{DD} voltage for the PIC® microcontroller product line, digital control system bias supply for AC-DC converters, 24V industrial input and similar applications.

5.2 Adjustable Output Voltage Calculations

To calculate the resistor divider values for the MCP16301/H devices, Equation 5-1 can be used. R_{TOP} is connected to V_{OUT} , R_{BOT} is connected to GND and both are connected to the V_{FB} input pin.

EQUATION 5-1:

$$R_{TOP} = R_{BOT} \times \left(\frac{V_{OUT}}{V_{FB}} - 1 \right)$$

EXAMPLE 5-1:

$$\begin{aligned} V_{OUT} &= 3.3V \\ V_{FB} &= 0.8V \\ R_{BOT} &= 10 \text{ k}\Omega \\ R_{TOP} &= 31.25 \text{ k}\Omega \text{ (standard value = 31.6 k}\Omega\text{)} \\ V_{OUT} &= 3.328V \text{ (using standard value)} \end{aligned}$$

EXAMPLE 5-2:

$$\begin{aligned} V_{OUT} &= 5.0V \\ V_{FB} &= 0.8V \\ R_{BOT} &= 10 \text{ k}\Omega \\ R_{TOP} &= 52.5 \text{ k}\Omega \text{ (standard value = 52.3 k}\Omega\text{)} \\ V_{OUT} &= 4.98V \text{ (using standard value)} \end{aligned}$$

The transconductance error amplifier gain is controlled by its internal impedance. The external resistor dividers have no effect on system gain, so a wide range of values can be used. A 10 k Ω bottom resistor is recommended as a good trade-off for quiescent current and noise immunity.

5.3 General Design Equations

The step-down converter duty cycle can be estimated using Equation 5-2 while operating in Continuous Inductor Current mode. This equation also counts the forward drop of the freewheeling diode and internal N-Channel MOSFET switch voltage drop. As the load current increases, the switch voltage drop and diode voltage drop increase, requiring a larger PWM duty cycle to maintain the output voltage regulation. Switch voltage drop is estimated by multiplying the switch current times the switch resistance (or $R_{DS(ON)}$).

EQUATION 5-2: CONTINUOUS INDUCTOR CURRENT DUTY CYCLE

$$D = \frac{(V_{OUT} + V_{Diode})}{(V_{IN} - (I_{SW} \times R_{DS(ON)})}$$

The MCP16301/H devices feature an integrated slope compensation to prevent the bimodal operation of the PWM duty cycle. Internally, half of the inductor current down slope is summed with the internal current sense signal. For the proper amount of slope compensation, it is recommended to keep the inductor down-slope current constant by varying the inductance with V_{OUT} , where $K = 0.22V/\mu H$.

EQUATION 5-3:

$$K = V_{OUT}/L$$

For $V_{OUT} = 3.3V$, an inductance of 15 μH is recommended.

TABLE 5-1: RECOMMENDED INDUCTOR VALUES

V_{OUT}	K	$L_{STANDARD}$
2.0V	0.20	10 μH
3.3V	0.22	15 μH
5.0V	0.23	22 μH
12V	0.21	56 μH
15V	0.22	68 μH

MCP16301/H

5.4 Input Capacitor Selection

The input capacitor of the step-down converter must filter the high input ripple current as a result of pulsing or chopping the input voltage. The input voltage pin of the MCP16301/H devices is used to supply voltage for the power train and as a source for internal bias. A low equivalent series resistance (ESR), preferably a ceramic capacitor, is recommended. The necessary capacitance is dependent upon the maximum load current and source impedance. Three capacitor parameters to keep in mind are the voltage rating, equivalent series resistance and the temperature rating. For wide temperature range applications, a multi-layer X7R dielectric is mandatory, while for applications with limited temperature range, a multi-layer X5R dielectric is acceptable. Typically, input capacitance between 4.7 μF and 10 μF is sufficient for most applications. For applications with 100 mA to 200 mA load, a 1 μF X7R capacitor can be used, depending on the input source and its impedance.

The input capacitor voltage rating should be a minimum of V_{IN} plus margin. [Table 5-2](#) contains the recommended range for the input capacitor value.

5.5 Output Capacitor Selection

The output capacitor helps in providing a stable output voltage during sudden load transients, and reduces the output voltage ripple. As with the input capacitor, X5R and X7R ceramic capacitors are well suited for this application.

The output capacitor value, type and equivalent series resistance will have a significant effect on the output ripple voltage and system stability. The range of the output capacitance is limited due to the integrated compensation of the MCP16301/H devices.

The output capacitor voltage rating should be a minimum of V_{OUT} plus margin. [Table 5-2](#) contains the recommended range for the input and output capacitor value:

TABLE 5-2: CAPACITOR VALUE RANGE

Parameter	Min	Max
C_{IN}	2.2 μF	none
C_{OUT}	20 μF	none

5.6 Inductor Selection

The MCP16301/H devices are designed to be used with small surface mount (SMT/SMD) inductors. Several specifications should be considered prior to selecting an inductor. To optimize system performance, the inductance value is determined based on the output voltage ([Table 5-1](#)), so the inductor ripple current is somehow constant over the output voltage range and can be calculated using [Equation 5-4](#).

EQUATION 5-4: INDUCTOR RIPPLE CURRENT

$$\Delta I_L = \frac{V_{\text{IN}} - V_{\text{OUT}}}{L} \times t_{\text{ON}}$$

EXAMPLE 5-3:

$$\begin{aligned} V_{\text{IN}} &= 12\text{V} \\ V_{\text{OUT}} &= 3.3\text{V} \\ I_{\text{OUT}} &= 600\text{ mA} \end{aligned}$$

Based on the inductor ripple current, the inductor peak current can be calculated using [Equation 5-5](#).

EQUATION 5-5: INDUCTOR PEAK CURRENT

$$I_{\text{LPK}} = \frac{\Delta I_L}{2} + I_{\text{OUT}}$$

$$\begin{aligned} \text{Inductor ripple current} &= 319\text{ mA} \\ \text{Inductor peak current} &= 760\text{ mA} \end{aligned}$$

In case of the aforementioned example, an inductor saturation rating higher than 760 mA is recommended. Low DCR inductors result in higher system efficiency. A trade-off between size, cost and efficiency should be made to achieve the desired results.

TABLE 5-3: MCP16301/H RECOMMENDED 3.3V INDUCTORS

Part Number	Value (µH)	DCR (Ω)	I _{SAT} (A)	Size WxLxH (mm)
Coilcraft®				
ME3220-153	15	0.52	0.90	3.2x2.5x2.0
LPS4414-153	15	0.440	0.92	4.3x4.3x1.4
LPS6235-153	15	0.125	2.00	6.0x6.0x3.5
MSS6132-153	15	0.135	1.56	6.1x6.1x3.2
MSS7341-153	15	0.057	1.78	7.3x7.3x4.1
ME3220-153	15	0.520	0.8	2.8x3.2x2.0
LPS3015-153	15	0.700	0.61	3.0x3.0x1.4
Würth Elektronik Group®				
74408942150	15	0.245	1.6	4.8x4.8x2.8
74438356150	15	0.230	2.1	4.1x4.1x2.1
74437324150	15	0.375	2.1	4.06x4.45x1.8
744025150	15	0.400	0.900	2.8x2.8x2.8
744031150	15	0.255	0.450	3.8x3.8x1.65
744042150	15	0.175	0.75	4.8x4.8x1.8
TDK-EPCOS®				
VLS3012HBX-150M	15	0.636	1.52	3.0x3.0x1.2
VLS3015CX-150M-H	15	0.428	0.57	3.0x3.0x1.5
VLS5045EX-150M	15	0.143	2.2	5.0x5.0x4.5
B82462G4153M000	15	0.097	1.05	6.0x6.0x2.2
Eaton				
SD12-150-R	15	0.48	0.692	5.2x5.2x1.2
SD18-150-R	15	0.266	0.831	5.2x5.2x1.8
SD20-150-R	15	0.193	0.718	5.2x5.2x2.0
SD3118-150-R	15	0.51	0.75	3.2x3.2x1.8
SD52-150-R	15	0.189	0.88	5.2x5.5.2.0
Sumida® Corporation				
CDPH4D19F	15	0.075	0.66	5.2x5.2x2.0
CDRH3D28	15	0.170	0.9	4.0x4.0x3.0

5.7 Freewheeling Diode

The freewheeling diode creates a path for inductor current flow after the internal switch is turned off. The average diode current is dependent upon output load current at duty cycle (D). The efficiency of the converter is a function of the forward drop and speed of the freewheeling diode. A low forward drop Schottky diode is recommended. The current rating and voltage rating of the diode are application dependent. The diode voltage rating should be a higher than V_{IN} plus margin. For example, a diode rating of 40V should be used for an application with a maximum input of 30V. The average diode current can be calculated using Equation 5-6.

EQUATION 5-6: DIODE AVERAGE CURRENT

$$I_{D1AVG} = (1 - D) \times I_{OUT}$$

EXAMPLE 5-4:

I _{OUT}	=	0.5A
V _{IN}	=	15V
V _{OUT}	=	5V
D	=	5/15
I _{D1AVG}	=	333 mA

A 0.5A to 1A diode is recommended and a list of recommended freewheeling diodes is shown in Table 5-4, below.

TABLE 5-4: FREEWHEELING DIODES

App	Manufacturer	Part Number	Rating
12 V _{IN} 600 mA	Diodes Incorporated®	DFLS120L-7	20V, 1A
24 V _{IN} 100 mA	Diodes Incorporated	B0540WS-7	40V, 0.5A
18 V _{IN} 600 mA	Diodes Incorporated	B130L-13-F	30V, 1A

5.8 Boost Diode

The boost diode is used to provide a charging path from the low-voltage gate drive source, while the switch node is low. The boost diode blocks the high voltage of the switch node from feeding back into the output voltage when the switch is turned on, forcing the switch node high.

A standard 1N4148 ultra-fast diode is recommended for its recovery speed, high voltage blocking capability, availability and cost. The voltage rating required for the boost diode is V_{IN}.

MCP16301/H

For low boost voltage applications, a small Schottky diode with the appropriately rated voltage can be used to lower the forward drop, while increasing the boost supply for gate drive.

5.9 Boost Capacitor

The boost capacitor is used to supply current for the internal high-side drive circuitry that is above the input voltage. The boost capacitor must store enough energy to completely drive the high-side switch on and off. A 0.1 μF X5R or X7R capacitor is recommended for all applications. The boost capacitor maximum voltage is 5.5V, so a 6.3V or 10V rated capacitor is recommended. In case of a noise-sensitive application, an additional resistor, connected in series with the boost capacitor, that will reduce the high-frequency noise associated with switching power supplies, can be added. A typical value for the resistor is 82 Ω .

5.10 Thermal Calculations

The MCP16301/H devices are available in a SOT-23-6 package. By calculating the power dissipation and applying the package thermal resistance (θ_{JA}), the junction temperature is estimated. The maximum continuous junction temperature rating for the MCP16301/H devices is +125°C.

To quickly estimate the internal power dissipation for the step-down switching regulator, an empirical calculation using measured efficiency can be used. Given the measured efficiency, the internal power dissipation is estimated by Equation 5-7. This power dissipation includes all internal and external component losses. For a quick internal estimate, subtract the estimated Schottky diode loss and inductor DCR loss from the P_{DIS} calculation in Equation 5-7.

EQUATION 5-7: TOTAL POWER DISSIPATION ESTIMATE

$$\left(\frac{V_{OUT} \times I_{OUT}}{\text{Efficiency}}\right) - (V_{OUT} \times I_{OUT}) = P_{Dis}$$

The difference between the first term, input power, and the second term, power delivered, is the total system power dissipation. The freewheeling Schottky diode losses are determined by calculating the average diode current and multiplying it by the diode forward drop. The inductor losses are estimated by $P_L = I_{OUT}^2 \times L_{DCR}$.

EQUATION 5-8: DIODE POWER DISSIPATION ESTIMATE

$$P_{Diode} = V_F \times ((1 - D) \times I_{OUT})$$

EXAMPLE 5-5:

V_{IN}	=	10V
V_{OUT}	=	5V
I_{OUT}	=	0.4A
Efficiency	=	90%
Total System Dissipation	=	222 mW
L_{DCR}	=	0.15 Ω
P_L	=	24 mW
Diode V_F	=	0.50
D	=	50%
P_{Diode}	=	125 mW

MCP16301/H internal power dissipation estimate:

$$P_{DIS} - P_L - P_{DIODE} = 73 \text{ mW}$$

θ_{JA}	=	198°C/W
Estimated Junction Temperature Rise	=	+14.5°C

5.11 PCB Layout Information

Good printed circuit board layout techniques are important to any switching circuitry, and switching power supplies are no different. When wiring the switching high-current paths, short and wide traces should be used. Therefore, it is important that the input and output capacitors should be placed as close as possible to the MCP16301/H devices, to minimize the loop area.

The feedback resistors and feedback signal should be routed away from the switching node and the switching current loop. When possible, ground planes and traces should be used to help shield the feedback signal and minimize noise and magnetic interference.

A good MCP16301/H layout starts with C_{IN} placement. C_{IN} supplies current to the input of the circuit when the switch is turned on. In addition to supplying high-frequency switch current, C_{IN} also provides a stable voltage source for the internal MCP16301/H circuitry. Unstable PWM operation can result if there are excessive transients or ringing on the V_{IN} pin of the MCP16301/H devices. In Figure 5-1, C_{IN} is placed close to pin 5. A ground plane on the bottom of the board provides a low resistive and inductive path for the return current. The next priority in placement is the freewheeling current loop formed by D1, C_{OUT} and L, while strategically placing C_{OUT} return close to C_{IN} return. Next, C_B and D_B should be placed between the boost pin and the switch node pin, SW. This leaves space close to the V_{FB} pin of the MCP16301/H devices to place R_{TOP} and R_{BOT} . R_{TOP} and R_{BOT} are routed away from the switch node, so noise is not coupled into the high-impedance V_{FB} input.

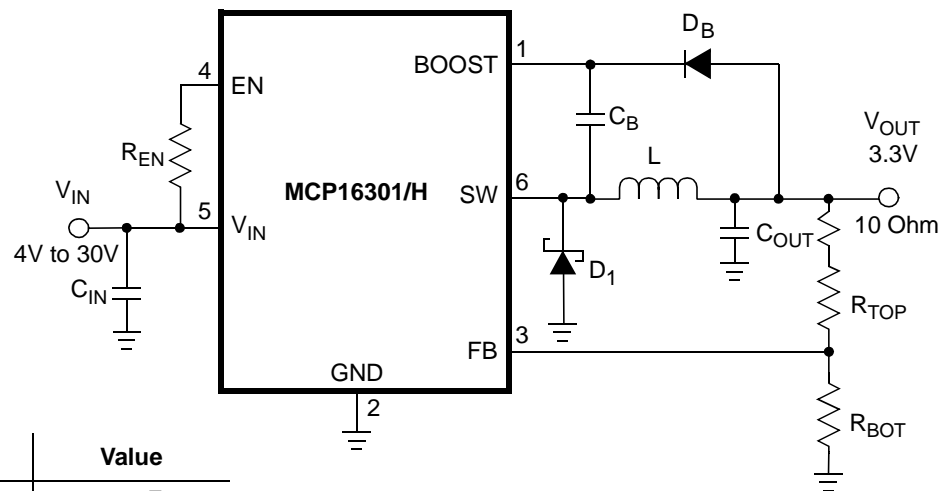
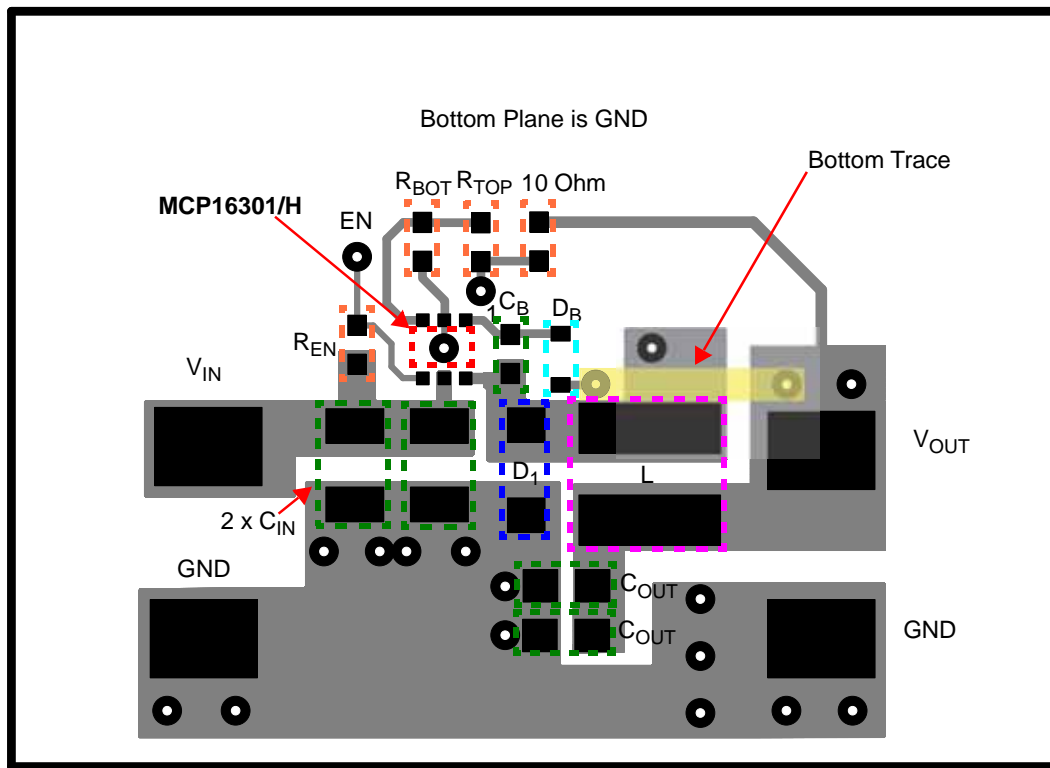

Component	Value
C_{IN}	10 μ F
C_{OUT}	2 x 10 μ F
L	15 μ H
R_{TOP}	31.6 k Ω
R_{BOT}	10 k Ω
D_1	B140
D_B	1N4148
C_B	100 nF

***Note:** The 10 Ω resistor is used at signal injection for network analyzer, to measure system gain and phase.

FIGURE 5-1: MCP16301/H SOT-23-6 Recommended Layout, 600 mA Design.

MCP16301/H

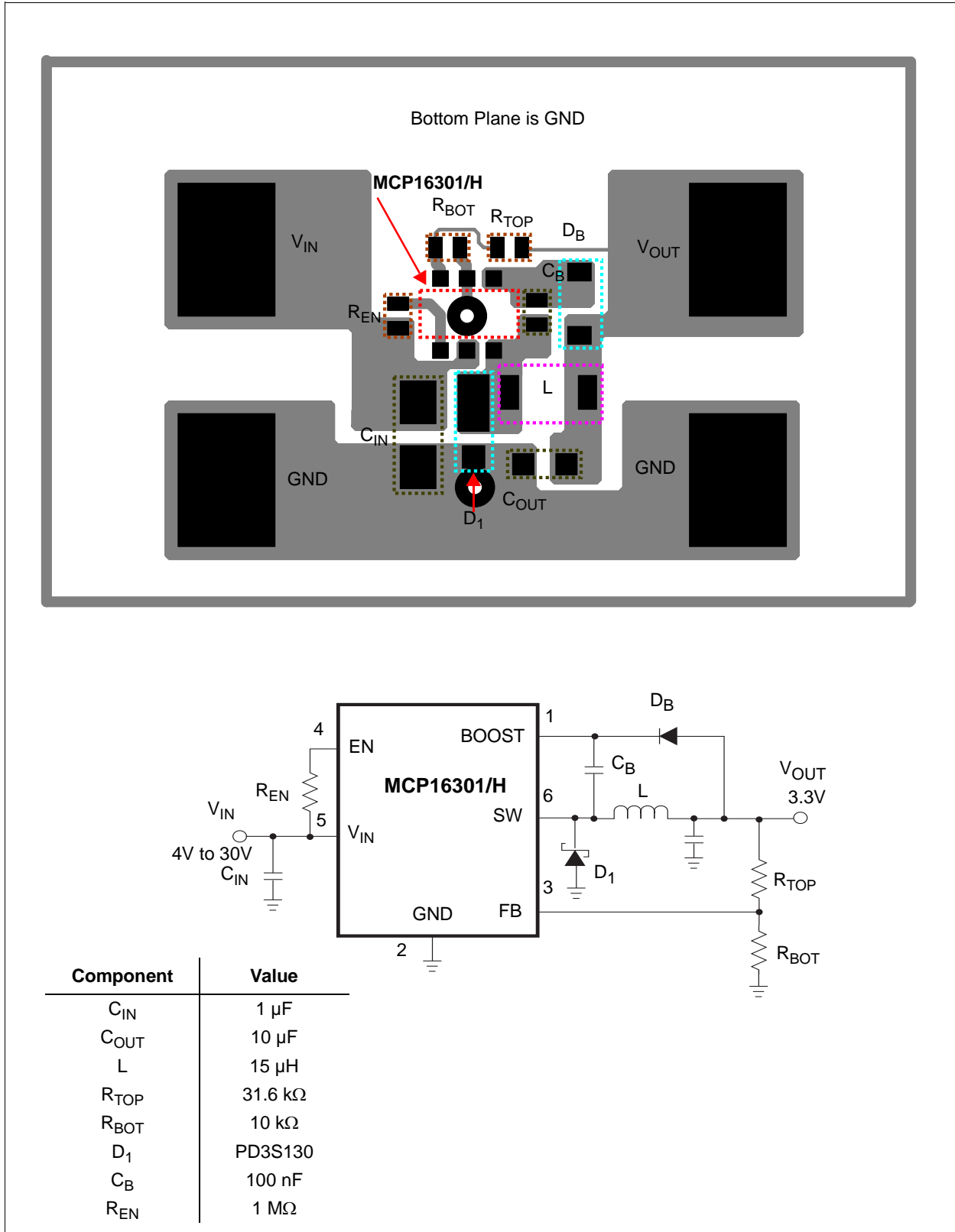

FIGURE 5-2: MCP16301/H SOT-23-6 Recommended Layout, 200 mA Design.

6.0 TYPICAL APPLICATION CIRCUITS

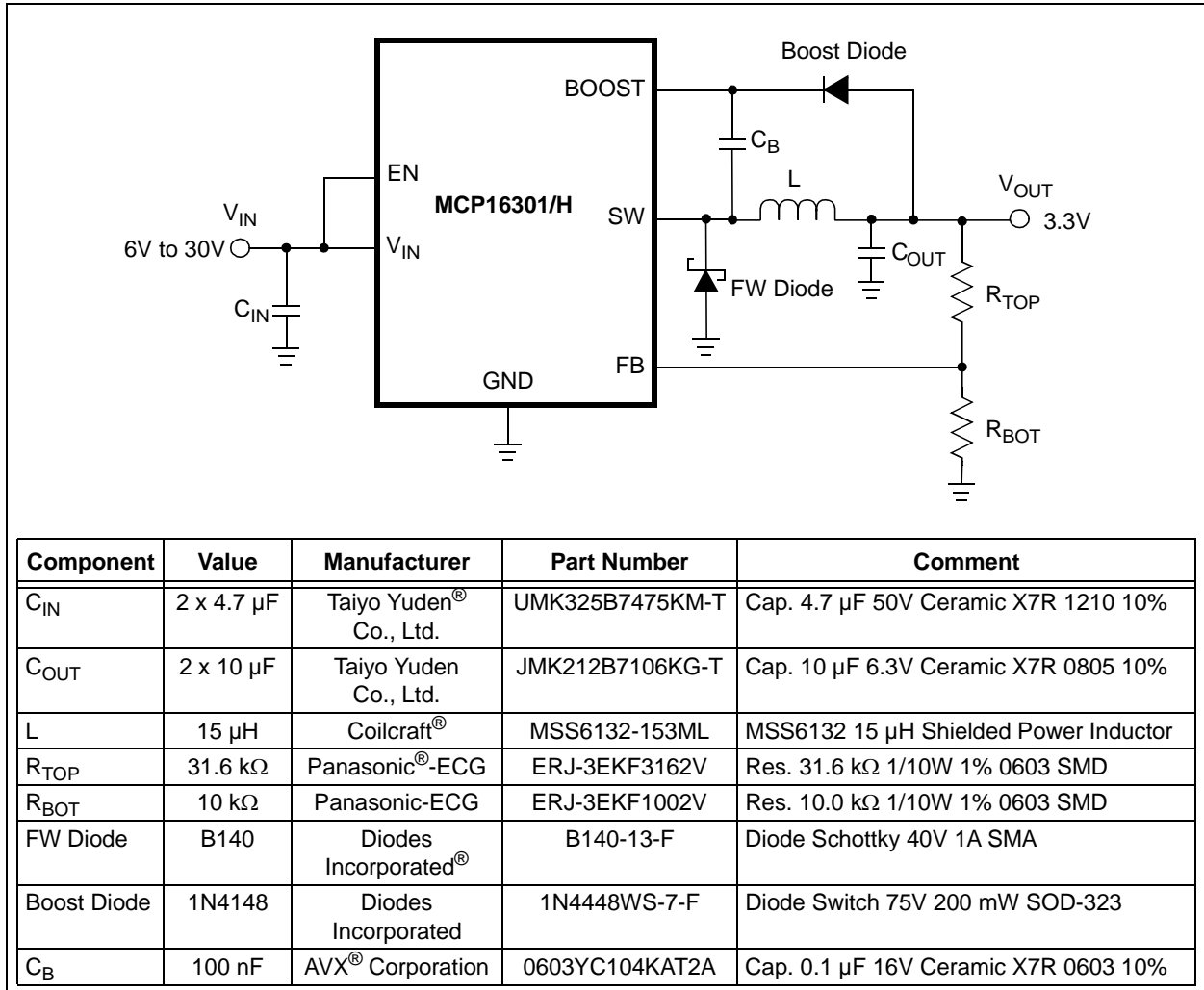
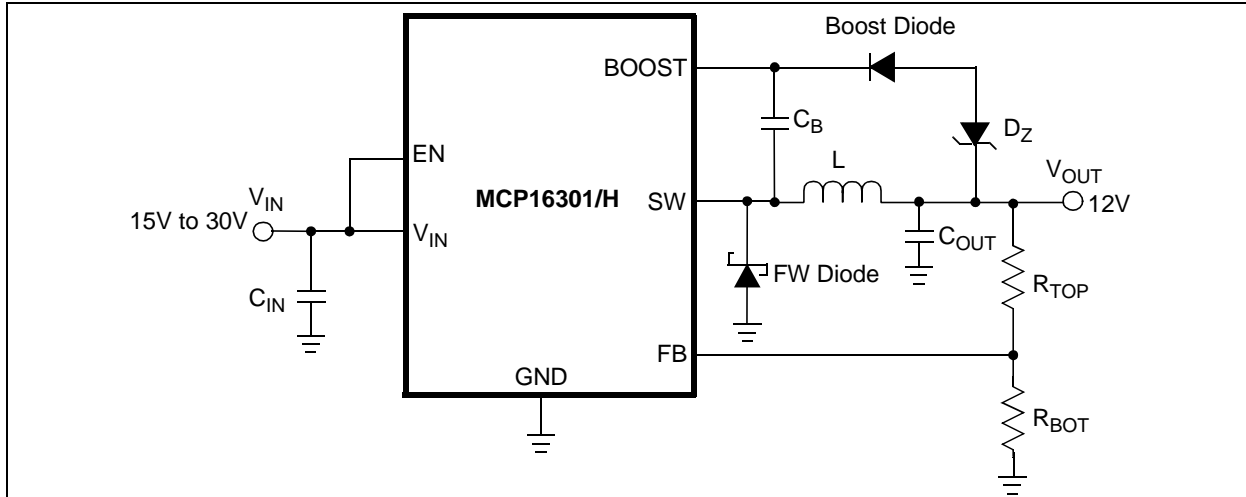

FIGURE 6-1: Typical Application 6V – 30V V_{IN} to 3.3V V_{OUT} .

MCP16301/H



Component	Value	Manufacturer	Part Number	Comment
C _{IN}	2 x 4.7 μF	Taiyo Yuden [®] Co., Ltd.	UMK325B7475KM-T	Cap. 4.7 uF 50V Ceramic X7R 1210 10%
C _{OUT}	2 x 10 μF	Taiyo Yuden Co., Ltd.	JMK212B7106KG-T	Cap. Ceramic 10 μF 25V X7R 10% 1206
L	56 μH	Coilcraft [®]	MSS6132-153ML	MSS7341 56 μH Shielded Power Inductor
R _{TOP}	140 kΩ	Panasonic [®] -ECG	ERJ-3EKF3162V	Res. 140 kΩ 1/10W 1% 0603 SMD
R _{BOT}	10 kΩ	Panasonic-ECG	ERJ-3EKF1002V	Res. 10.0 kΩ 1/10W 1% 0603 SMD
FW Diode	B140	Diodes Incorporated [®]	B140-13-F	Diode Schottky 40V 1A SMA
Boost Diode	1N4148	Diodes Incorporated	1N4448WS-7-F	Diode Switch 75V 200 mW SOD-323
C _B	100 nF	AVX [®] Corporation	0603YC104KAT2A	Cap. 0.1 μF 16V Ceramic X7R 0603 10%
D _Z	7.5V Zener	Diodes Incorporated	MMSZ5236BS-7-F	Diode Zener 7.5V 200 mW SOD-323

FIGURE 6-2: Typical Application 15V – 30V Input; 12V Output.

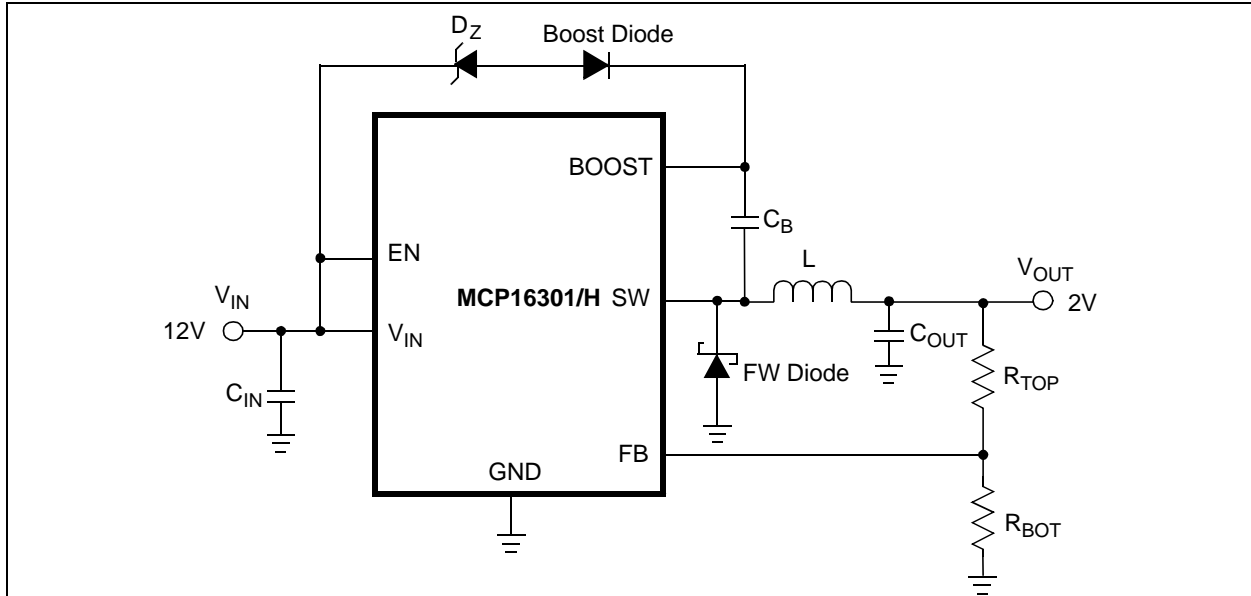

Component	Value	Manufacturer	Part Number	Comment
C _{IN}	10 μ F	Taiyo Yuden [®] Co., Ltd.	EMK316B7106KL-TD	Cap. Ceramic 10 μ F 16V X7R 10% 1206
C _{OUT}	22 μ F	Taiyo Yuden Co., Ltd.	JMK316B7226ML-T	Cap. Ceramic 22 μ F 6.3V X7R 1206
L	10 μ H	Coilcraft [®]	MSS4020-103ML	10 μ H Shielded Power Inductor
R _{TOP}	15 k Ω	Panasonic [®] -ECG	ERJ-3EKF1502V	Res. 15.0 k Ω 1/10W 1% 0603 SMD
R _{BOT}	10 k Ω	Panasonic-ECG	ERJ-3EKF1002V	Res. 10.0 k Ω 1/10W 1% 0603 SMD
FW Diode	PD3S	Diodes Incorporated [®]	PD3S120L-7	Diode Schottky 1A 20V POWERDI323
Boost Diode	1N4148	Diodes Incorporated	1N4448WS-7-F	Diode Switch 75V 200 mW SOD-323
C _B	100 nF	AVX [®] Corporation	0603YC104KAT2A	Cap. 0.1 μ F 16V Ceramic X7R 0603 10%
D _Z	7.5V Zener	Diodes Incorporated	MMSZ5236BS-7-F	Diode Zener 7.5V 200 mW SOD-323

FIGURE 6-3: Typical Application 12V Input; 2V Output at 600 mA.

MCP16301/H

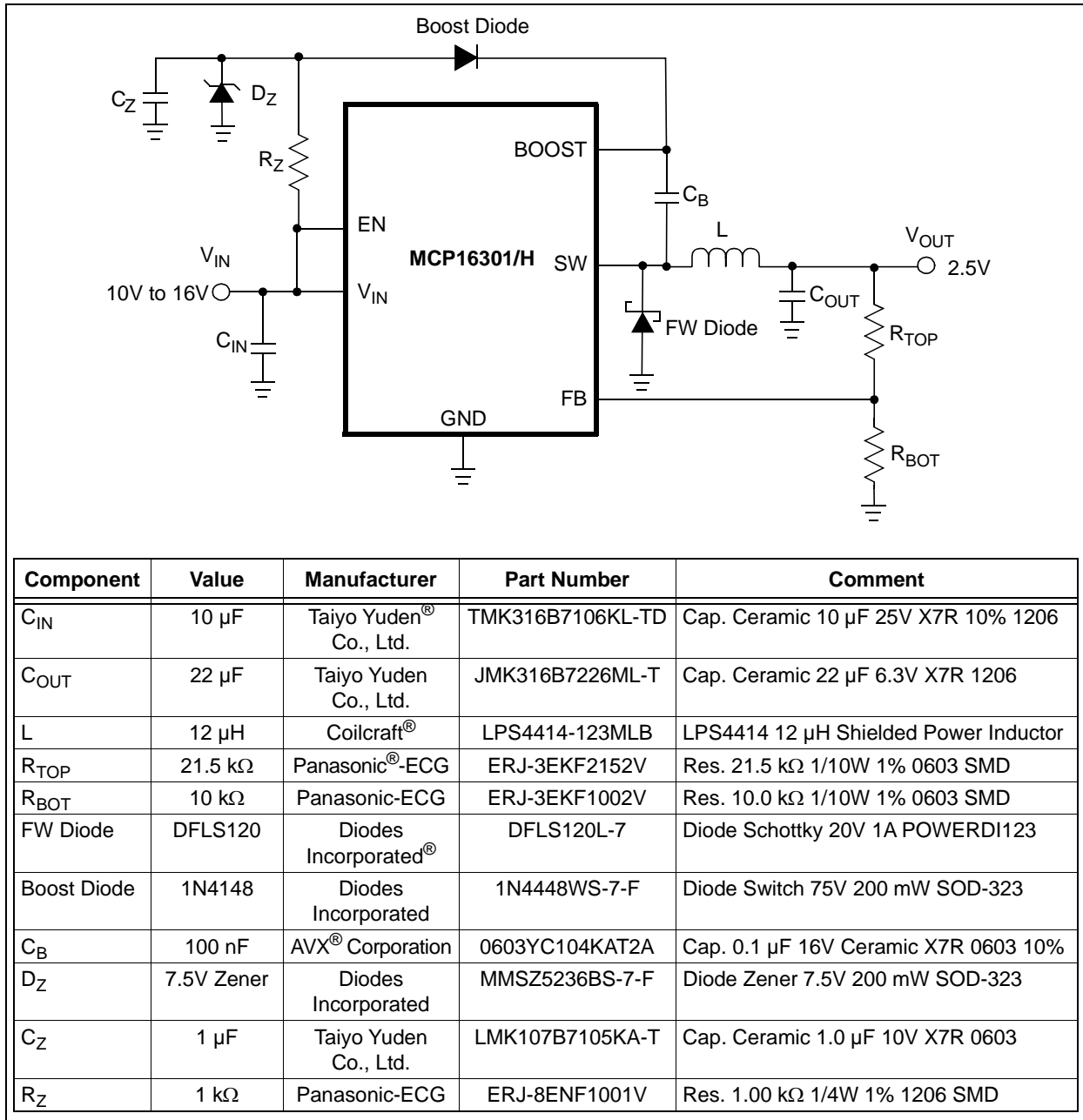
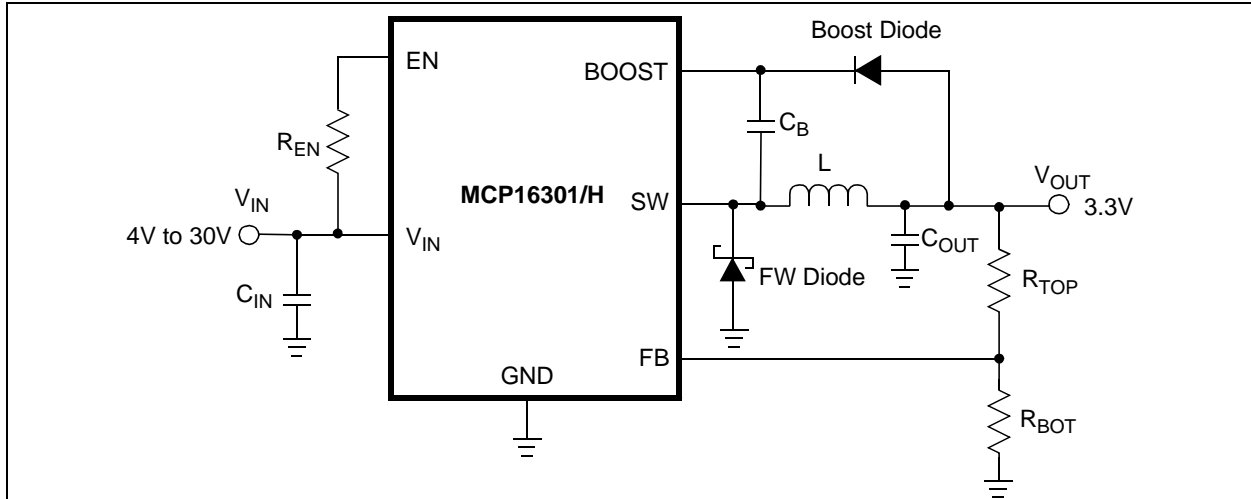

FIGURE 6-4: Typical Application 10V to 16V V_{IN} to 2.5V V_{OUT} .



Component	Value	Manufacturer	Part Number	Comment
C _{IN}	1 μF	Taiyo Yuden [®] Co., Ltd.	GMK212B7105KG-T	Cap. Ceramic 1.0 μF 35V X7R 0805
C _{OUT}	10 μF	Taiyo Yuden Co., Ltd.	JMK107BJ106MA-T	Cap. Ceramic 10 μF 6.3V X5R 0603
L	15 μH	Coilcraft [®]	LPS3015-153MLB	Inductor Power 15 μH 0.61A SMD
R _{TOP}	31.6 kΩ	Panasonic [®] -ECG	ERJ-2RKF3162X	Res. 31.6 kΩ 1/10W 1% 0402 SMD
R _{BOT}	10 kΩ	Panasonic-ECG	ERJ-3EKF1002V	Res. 10.0 kΩ 1/10W 1% 0603 SMD
FW Diode	B0540	Diodes Incorporated [®]	B0540WS-7	Diode Schottky 0.5A 40V SOD323
Boost Diode	1N4148	Diodes Incorporated	1N4448WS-7-F	Diode Switch 75V 200 mW SOD-323
C _B	100 nF	TDK [®] Corporation	C1005X5R0J104M	Cap. Ceramic 0.10 μF 6.3V X5R 0402
R _{EN}	10 MΩ	Panasonic-ECG	ERJ-2RKF1004X	Res. 1.00 MΩ 1/10W 1% 0402 SMD

FIGURE 6-5: Typical Application 4V to 30V V_{IN} to 3.3V V_{OUT} at 150 mA.

MCP16301/H

NOTES:

7.0 PACKAGING INFORMATION

7.1 Package Marking Information

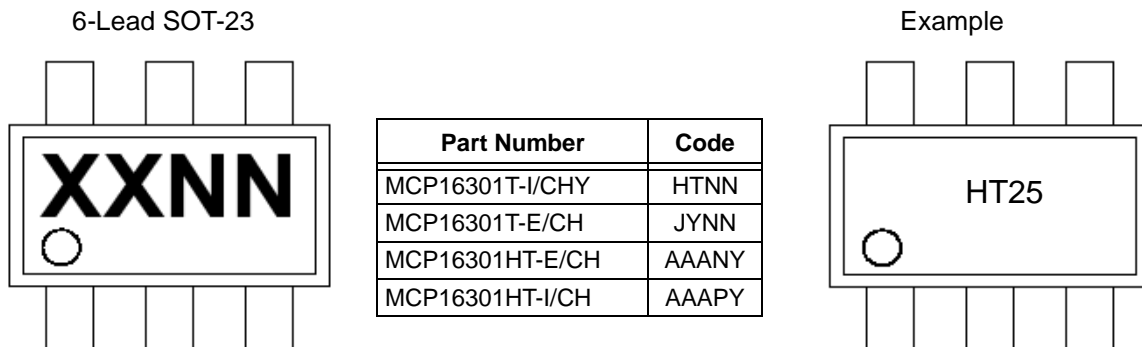

Legend:	XX...X	Customer-specific information
	Y	Year code (last digit of calendar year)
	YY	Year code (last 2 digits of calendar year)
	WW	Week code (week of January 1 is week '01')
	NNN	Alphanumeric traceability code
	(e3)	Pb-free JEDEC® designator for Matte Tin (Sn)
	*	This package is Pb-free. The Pb-free JEDEC designator (e3) can be found on the outer packaging for this package.
Note:	In the event the full Microchip part number cannot be marked on one line, it will be carried over to the next line, thus limiting the number of available characters for customer-specific information.	

MCP16301/H

6-Lead Plastic Small Outline Transistor (CH, CHY) [SOT-23]

Note: For the most current package drawings, please see the Microchip Packaging Specification located at <http://www.microchip.com/packaging>

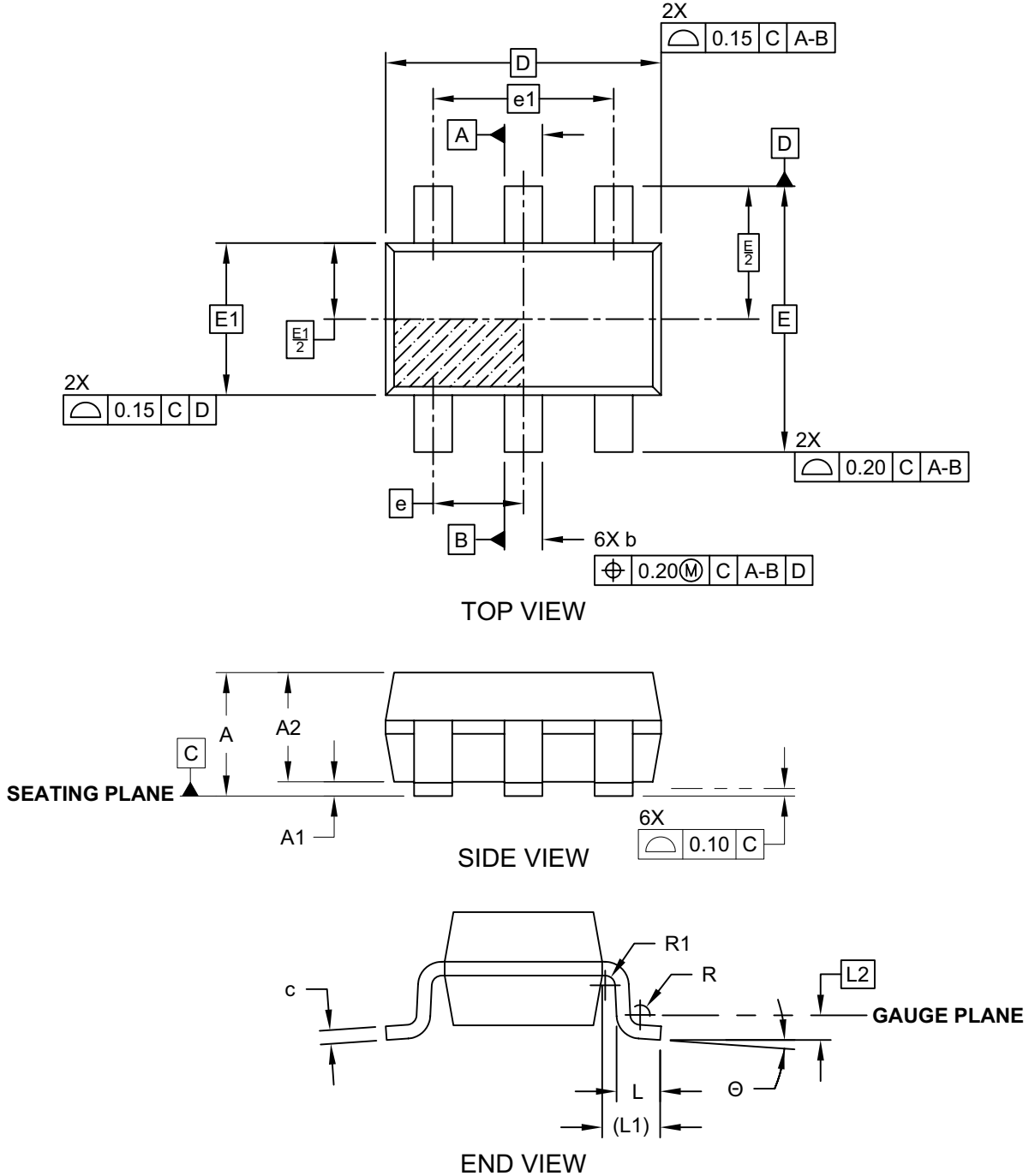

Microchip Technology Drawing C04-028C (CH) Sheet 1 of 2

6-Lead Plastic Small Outline Transistor (CH, CHY) [SOT-23]

Note: For the most current package drawings, please see the Microchip Packaging Specification located at <http://www.microchip.com/packaging>

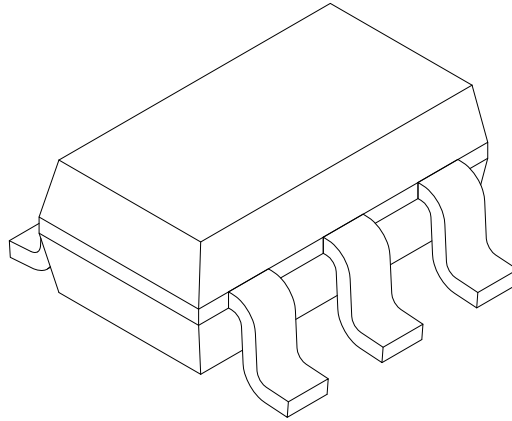

Dimension Limits	Units	MILLIMETERS		
		MIN	NOM	MAX
Number of Leads	N	6		
Pitch	e	0.95 BSC		
Outside lead pitch	e1	1.90 BSC		
Overall Height	A	0.90	-	1.45
Molded Package Thickness	A2	0.89	1.15	1.30
Standoff	A1	0.00	-	0.15
Overall Width	E	2.80 BSC		
Molded Package Width	E1	1.60 BSC		
Overall Length	D	2.90 BSC		
Foot Length	L	0.30	0.45	0.60
Footprint	L1	0.60 REF		
Seating Plane to Gauge Plane	L1	0.25 BSC		
Foot Angle	φ	0°	-	10°
Lead Thickness	c	0.08	-	0.26
Lead Width	b	0.20	-	0.51

Notes:

- Dimensions D and E1 do not include mold flash or protrusions. Mold flash or protrusions shall not exceed 0.25mm per side.
- Dimensioning and tolerancing per ASME Y14.5M
 BSC: Basic Dimension. Theoretically exact value shown without tolerances.
 REF: Reference Dimension, usually without tolerance, for information purposes only.

Microchip Technology Drawing C04-028C (CH) Sheet 2 of 2

MCP16301/H

6-Lead Plastic Small Outline Transistor (CH, CHY) [SOT-23]

Note: For the most current package drawings, please see the Microchip Packaging Specification located at <http://www.microchip.com/packaging>

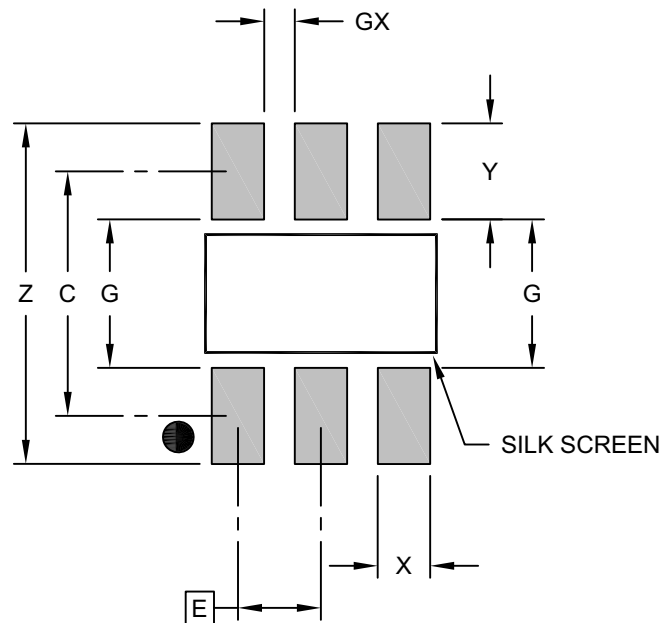

RECOMMENDED LAND PATTERN

Dimension Limits	Units	MILLIMETERS		
		MIN	NOM	MAX
Contact Pitch	E	0.95 BSC		
Contact Pad Spacing	C		2.80	
Contact Pad Width (X3)	X			0.60
Contact Pad Length (X3)	Y			1.10
Distance Between Pads	G	1.70		
Distance Between Pads	GX	0.35		
Overall Width	Z			3.90

Notes:

1. Dimensioning and tolerancing per ASME Y14.5M

BSC: Basic Dimension. Theoretically exact value shown without tolerances.

Microchip Technology Drawing No. C04-2028B (CH)

APPENDIX A: REVISION HISTORY

Revision E (January 2021)

The following is the list of modifications:

1. Added AEC-Q100 Qualification.
2. Updated the **Features** section.
3. Updated the **General Description** section.
4. Updated **Section 3.0, Pin Descriptions**.
5. Updated **Section 4.0, Detailed Description**.
6. Updated **Section 5.0, Application Information**.
7. Updated **Section 6.0, Typical Application Circuits**.
8. Updated the **Product Identification System** section.

Revision D (April 2015)

The following is the list of modifications:

1. Updated the **Features** section.
2. Updated the input voltage and resistor values in the **Typical Applications** section.
3. Added **Figure 2-6**.
4. Updated **Example 5-1** and **Example 5-2**.
5. Updated the R_{TOP} value in **Figures 5-1, 5-2, 6-1** and **6-5**.

Revision C (November 2013)

The following is the list of modifications:

1. Added new device to the family (MCP16301H) and related information throughout the document.
2. Added package markings and drawings for the MCP16301H device.
3. Updated the **Product Identification System** section.

Revision B (November 2012)

The following is the list of modifications:

1. Added Extended Temperature characteristic.
2. Added 6-lead SOT-23 package version (CH code).
3. Updated the following characterization charts: **Figures 2-7, 2-8, 2-9, 2-10, 2-12, 2-13** and **2-14**.
4. Updated **Section 7.0, Packaging Information**.
5. Updated the **Product Identification System** section.

Revision A (May 2011)

- Original Release of this Document.

MCP16301/H

NOTES:

PRODUCT IDENTIFICATION SYSTEM

To order or obtain information, e.g., on pricing or delivery, refer to the factory or the listed sales office.

<u>PART NO.</u>	<u>X</u>	<u>-X</u>	<u>/XXX</u>	<u>XXX</u>	Examples:																																																						
Device	Tape and Reel	Temperature Range	Package	Qualification																																																							
<table border="1"> <tr> <td>Device:</td> <td>MCP16301T:</td> <td>High-Voltage Step-Down Regulator, Tape and Reel</td> <td></td> <td></td> <td></td> </tr> <tr> <td></td> <td>MCP16301HT:</td> <td>High-Voltage Step-Down Regulator, Tape and Reel</td> <td></td> <td></td> <td></td> </tr> <tr> <td>Temperature Range:</td> <td>E</td> <td>= -40°C to +125°C (Extended)</td> <td></td> <td></td> <td></td> </tr> <tr> <td></td> <td>I</td> <td>= -40°C to +85°C (Industrial)</td> <td></td> <td></td> <td></td> </tr> <tr> <td>Package:</td> <td>CH</td> <td>= Plastic Small Outline Transistor (SOT-23), 6-lead</td> <td></td> <td></td> <td></td> </tr> <tr> <td></td> <td>CHY*</td> <td>= Plastic Small Outline Transistor (SOT-23), 6-lead</td> <td></td> <td></td> <td></td> </tr> <tr> <td></td> <td>*Y</td> <td>= Nickel palladium gold manufacturing designator.</td> <td></td> <td></td> <td></td> </tr> <tr> <td>Qualification:</td> <td>(Blank)</td> <td>= Standard Qualification</td> <td></td> <td></td> <td></td> </tr> <tr> <td></td> <td>VAO</td> <td>= AEC-Q100 Automotive Qualification</td> <td></td> <td></td> <td></td> </tr> </table>					Device:	MCP16301T:	High-Voltage Step-Down Regulator, Tape and Reel					MCP16301HT:	High-Voltage Step-Down Regulator, Tape and Reel				Temperature Range:	E	= -40°C to +125°C (Extended)					I	= -40°C to +85°C (Industrial)				Package:	CH	= Plastic Small Outline Transistor (SOT-23), 6-lead					CHY*	= Plastic Small Outline Transistor (SOT-23), 6-lead					*Y	= Nickel palladium gold manufacturing designator.				Qualification:	(Blank)	= Standard Qualification					VAO	= AEC-Q100 Automotive Qualification				
Device:	MCP16301T:	High-Voltage Step-Down Regulator, Tape and Reel																																																									
	MCP16301HT:	High-Voltage Step-Down Regulator, Tape and Reel																																																									
Temperature Range:	E	= -40°C to +125°C (Extended)																																																									
	I	= -40°C to +85°C (Industrial)																																																									
Package:	CH	= Plastic Small Outline Transistor (SOT-23), 6-lead																																																									
	CHY*	= Plastic Small Outline Transistor (SOT-23), 6-lead																																																									
	*Y	= Nickel palladium gold manufacturing designator.																																																									
Qualification:	(Blank)	= Standard Qualification																																																									
	VAO	= AEC-Q100 Automotive Qualification																																																									
					a) MCP16301T-I/CHY: Step-Down Regulator, Tape and Reel, Industrial Temperature, 6LD SOT-23 package																																																						
					b) MCP16301T-E/CH: Step-Down Regulator, Tape and Reel, Extended Temperature, 6LD SOT-23 package																																																						
					c) MCP16301HT-E/CH: Step-Down Regulator, Tape and Reel, Extended Temperature, 6LD SOT-23 package																																																						
					d) MCP16301HT-E/CHVAO: Step-Down Regulator, Tape and Reel, Extended Temperature, 6LD SOT-23 package Automotive Qualified																																																						
					e) MCP16301T-E/CHVAO: Step-Down Regulator, Tape and Reel, Extended Temperature, 6LD SOT-23 package Automotive Qualified																																																						
					Note 1: Tape and Reel identifier only appears in the catalog part number description. This identifier is used for ordering purposes and is not printed on the device package. Check with your Microchip Sales Office for package availability with the Tape and Reel option.																																																						

MCP16301/H

NOTES:

Note the following details of the code protection feature on Microchip devices:

- Microchip products meet the specifications contained in their particular Microchip Data Sheet.
- Microchip believes that its family of products is secure when used in the intended manner and under normal conditions.
- There are dishonest and possibly illegal methods being used in attempts to breach the code protection features of the Microchip devices. We believe that these methods require using the Microchip products in a manner outside the operating specifications contained in Microchip's Data Sheets. Attempts to breach these code protection features, most likely, cannot be accomplished without violating Microchip's intellectual property rights.
- Microchip is willing to work with any customer who is concerned about the integrity of its code.
- Neither Microchip nor any other semiconductor manufacturer can guarantee the security of its code. Code protection does not mean that we are guaranteeing the product is "unbreakable." Code protection is constantly evolving. We at Microchip are committed to continuously improving the code protection features of our products. Attempts to break Microchip's code protection feature may be a violation of the Digital Millennium Copyright Act. If such acts allow unauthorized access to your software or other copyrighted work, you may have a right to sue for relief under that Act.

Information contained in this publication is provided for the sole purpose of designing with and using Microchip products. Information regarding device applications and the like is provided only for your convenience and may be superseded by updates. It is your responsibility to ensure that your application meets with your specifications.

THIS INFORMATION IS PROVIDED BY MICROCHIP "AS IS". MICROCHIP MAKES NO REPRESENTATIONS OR WARRANTIES OF ANY KIND WHETHER EXPRESS OR IMPLIED, WRITTEN OR ORAL, STATUTORY OR OTHERWISE, RELATED TO THE INFORMATION INCLUDING BUT NOT LIMITED TO ANY IMPLIED WARRANTIES OF NON-INFRINGEMENT, MERCHANTABILITY, AND FITNESS FOR A PARTICULAR PURPOSE OR WARRANTIES RELATED TO ITS CONDITION, QUALITY, OR PERFORMANCE.

IN NO EVENT WILL MICROCHIP BE LIABLE FOR ANY INDIRECT, SPECIAL, PUNITIVE, INCIDENTAL OR CONSEQUENTIAL LOSS, DAMAGE, COST OR EXPENSE OF ANY KIND WHATSOEVER RELATED TO THE INFORMATION OR ITS USE, HOWEVER CAUSED, EVEN IF MICROCHIP HAS BEEN ADVISED OF THE POSSIBILITY OR THE DAMAGES ARE FORESEEABLE. TO THE FULLEST EXTENT ALLOWED BY LAW, MICROCHIP'S TOTAL LIABILITY ON ALL CLAIMS IN ANY WAY RELATED TO THE INFORMATION OR ITS USE WILL NOT EXCEED THE AMOUNT OF FEES, IF ANY, THAT YOU HAVE PAID DIRECTLY TO MICROCHIP FOR THE INFORMATION. Use of Microchip devices in life support and/or safety applications is entirely at the buyer's risk, and the buyer agrees to defend, indemnify and hold harmless Microchip from any and all damages, claims, suits, or expenses resulting from such use. No licenses are conveyed, implicitly or otherwise, under any Microchip intellectual property rights unless otherwise stated.

Trademarks

The Microchip name and logo, the Microchip logo, Adaptec, AnyRate, AVR, AVR logo, AVR Freaks, BesTime, BitCloud, chipKIT, chipKIT logo, CryptoMemory, CryptoRF, dsPIC, FlashFlex, flexPWR, HELDO, IGL00, JukeBlox, KeeLoq, Kleer, LANCheck, LinkMD, maXStylus, maXTouch, MediaLB, megaAVR, Microsemi, Microsemi logo, MOST, MOST logo, MPLAB, OptoLyzr, PackeTime, PIC, picoPower, PICSTART, PIC32 logo, PolarFire, Prochip Designer, QTouch, SAM-BA, SenGenuity, SpyNIC, SST, SST Logo, SuperFlash, Symmetricom, SyncServer, Tachyon, TimeSource, tinyAVR, UNI/O, Vectron, and XMEGA are registered trademarks of Microchip Technology Incorporated in the U.S.A. and other countries.

AgileSwitch, APT, ClockWorks, The Embedded Control Solutions Company, EtherSynch, FlashTec, Hyper Speed Control, HyperLight Load, IntelliMOS, Libero, motorBench, mTouch, Powermite 3, Precision Edge, ProASIC, ProASIC Plus, ProASIC Plus logo, Quiet-Wire, SmartFusion, SyncWorld, Temux, TimeCesium, TimeHub, TimePictra, TimeProvider, WinPath, and ZL are registered trademarks of Microchip Technology Incorporated in the U.S.A.

Adjacent Key Suppression, AKS, Analog-for-the-Digital Age, Any Capacitor, AnyIn, AnyOut, Augmented Switching, BlueSky, BodyCom, CodeGuard, CryptoAuthentication, CryptoAutomotive, CryptoCompanion, CryptoController, dsPICDEM, dsPICDEM.net, Dynamic Average Matching, DAM, ECAN, Espresso T1S, EtherGREEN, IdealBridge, In-Circuit Serial Programming, ICSP, INICnet, Intelligent Paralleling, Inter-Chip Connectivity, JitterBlocker, maxCrypto, maxView, memBrain, Mindi, MiWi, MPASM, MPF, MPLAB Certified logo, MPLIB, MPLINK, MultiTRAK, NetDetach, Omniscient Code Generation, PICDEM, PICDEM.net, PICkit, PICtail, PowerSmart, PureSilicon, QMatrix, REAL ICE, Ripple Blocker, RTAX, RTG4, SAM-ICE, Serial Quad I/O, simpleMAP, SimpliPHY, SmartBuffer, SMART-I.S., storClad, SQI, SuperSwitcher, SuperSwitcher II, Switchtec, SynchroPHY, Total Endurance, TSHARC, USBCheck, VariSense, VectorBlox, VeriPHY, ViewSpan, WiperLock, XpressConnect, and ZENA are trademarks of Microchip Technology Incorporated in the U.S.A. and other countries.

SQTP is a service mark of Microchip Technology Incorporated in the U.S.A.

The Adaptec logo, Frequency on Demand, Silicon Storage Technology, and Symmcom are registered trademarks of Microchip Technology Inc. in other countries.

GestIC is a registered trademark of Microchip Technology Germany II GmbH & Co. KG, a subsidiary of Microchip Technology Inc., in other countries.

All other trademarks mentioned herein are property of their respective companies.

© 2011-2021, Microchip Technology Incorporated, All Rights Reserved.

ISBN: 978-1-5224-7315-2

For information regarding Microchip's Quality Management Systems, please visit www.microchip.com/quality.



MICROCHIP

Worldwide Sales and Service

AMERICAS

Corporate Office
2355 West Chandler Blvd.
Chandler, AZ 85224-6199
Tel: 480-792-7200
Fax: 480-792-7277
Technical Support:
[http://www.microchip.com/
support](http://www.microchip.com/support)
Web Address:
www.microchip.com

Atlanta

Duluth, GA
Tel: 678-957-9614
Fax: 678-957-1455

Austin, TX

Tel: 512-257-3370

Boston

Westborough, MA
Tel: 774-760-0087
Fax: 774-760-0088

Chicago

Itasca, IL
Tel: 630-285-0071
Fax: 630-285-0075

Dallas

Addison, TX
Tel: 972-818-7423
Fax: 972-818-2924

Detroit

Novi, MI
Tel: 248-848-4000

Houston, TX

Tel: 281-894-5983

Indianapolis

Noblesville, IN
Tel: 317-773-8323
Fax: 317-773-5453
Tel: 317-536-2380

Los Angeles

Mission Viejo, CA
Tel: 949-462-9523
Fax: 949-462-9608
Tel: 951-273-7800

Raleigh, NC

Tel: 919-844-7510

New York, NY

Tel: 631-435-6000

San Jose, CA

Tel: 408-735-9110
Tel: 408-436-4270

Canada - Toronto

Tel: 905-695-1980
Fax: 905-695-2078

ASIA/PACIFIC

Australia - Sydney
Tel: 61-2-9868-6733

China - Beijing
Tel: 86-10-8569-7000

China - Chengdu
Tel: 86-28-8665-5511

China - Chongqing
Tel: 86-23-8980-9588

China - Dongguan
Tel: 86-769-8702-9880

China - Guangzhou
Tel: 86-20-8755-8029

China - Hangzhou
Tel: 86-571-8792-8115

China - Hong Kong SAR
Tel: 852-2943-5100

China - Nanjing
Tel: 86-25-8473-2460

China - Qingdao
Tel: 86-532-8502-7355

China - Shanghai
Tel: 86-21-3326-8000

China - Shenyang
Tel: 86-24-2334-2829

China - Shenzhen
Tel: 86-755-8864-2200

China - Suzhou
Tel: 86-186-6233-1526

China - Wuhan
Tel: 86-27-5980-5300

China - Xian
Tel: 86-29-8833-7252

China - Xiamen
Tel: 86-592-2388138

China - Zhuhai
Tel: 86-756-3210040

ASIA/PACIFIC

India - Bangalore
Tel: 91-80-3090-4444

India - New Delhi
Tel: 91-11-4160-8631

India - Pune
Tel: 91-20-4121-0141

Japan - Osaka
Tel: 81-6-6152-7160

Japan - Tokyo
Tel: 81-3-6880-3770

Korea - Daegu
Tel: 82-53-744-4301

Korea - Seoul
Tel: 82-2-554-7200

Malaysia - Kuala Lumpur
Tel: 60-3-7651-7906

Malaysia - Penang
Tel: 60-4-227-8870

Philippines - Manila
Tel: 63-2-634-9065

Singapore
Tel: 65-6334-8870

Taiwan - Hsin Chu
Tel: 886-3-577-8366

Taiwan - Kaohsiung
Tel: 886-7-213-7830

Taiwan - Taipei
Tel: 886-2-2508-8600

Thailand - Bangkok
Tel: 66-2-694-1351

Vietnam - Ho Chi Minh
Tel: 84-28-5448-2100

EUROPE

Austria - Wels
Tel: 43-7242-2244-39
Fax: 43-7242-2244-393

Denmark - Copenhagen
Tel: 45-4485-5910
Fax: 45-4485-2829

Finland - Espoo
Tel: 358-9-4520-820

France - Paris
Tel: 33-1-69-53-63-20
Fax: 33-1-69-30-90-79

Germany - Garching
Tel: 49-8931-9700

Germany - Haan
Tel: 49-2129-3766400

Germany - Heilbronn
Tel: 49-7131-72400

Germany - Karlsruhe
Tel: 49-721-625370

Germany - Munich
Tel: 49-89-627-144-0
Fax: 49-89-627-144-44

Germany - Rosenheim
Tel: 49-8031-354-560

Israel - Ra'anana
Tel: 972-9-744-7705

Italy - Milan
Tel: 39-0331-742611
Fax: 39-0331-466781

Italy - Padova
Tel: 39-049-7625286

Netherlands - Drunen
Tel: 31-416-690399
Fax: 31-416-690340

Norway - Trondheim
Tel: 47-7288-4388

Poland - Warsaw
Tel: 48-22-3325737

Romania - Bucharest
Tel: 40-21-407-87-50

Spain - Madrid
Tel: 34-91-708-08-90
Fax: 34-91-708-08-91

Sweden - Gothenberg
Tel: 46-31-704-60-40

Sweden - Stockholm
Tel: 46-8-5090-4654

UK - Wokingham
Tel: 44-118-921-5800
Fax: 44-118-921-5820