

## Ambient Light Sensor Surface - Mount ALS-PT19-315C/L177/TR8

### Features

- Close responsively to the human eye spectrum
- Light to Current, analog output
- Good output linearity across wide illumination range
- Low sensitivity variation across various light sources
- Guaranteed temperature performance, -40°C to 85°C
- Wide supply voltage range, 2.5V to 5.5V
- Size : 1.7mm(L)\*0.8mm(W)\*0.6mm(H)
- The product itself will remain within RoHS compliant version
- Compliance with EU REACH
- Compliance Halogen Free(Br < 900ppm, Cl < 900ppm, Br+Cl < 1500ppm)



### Description

The ALS-PT19-315C/L177/TR8 is a low cost ambient light sensor, consisting of phototransistor in miniature SMD. EVERLIGHT ALS series product are a good effective solution to the power saving of display backlighting of mobile appliances, such as the mobile phones, NB and PDAs. Due to the high rejection ratio of infrared radiation, the spectral response of the ambient light sensor is close to that of human eyes.

### Applications

- Detection of ambient light to control display backlighting
  - Mobile devices – mobile phones, PDAs
  - Computing device – TFT LCD monitor for Notebook computer
  - Consumer device – TFT LCD TV, plasma TV, video camera, digital camera, toys
- Automatic residential and commercial management
- Automatic contrast enhancement for electronic signboard
- Ambient light monitoring device for daylight and artificial light
  - Street light, CCD/CCTV

**Package Dimensions**

**Top View**

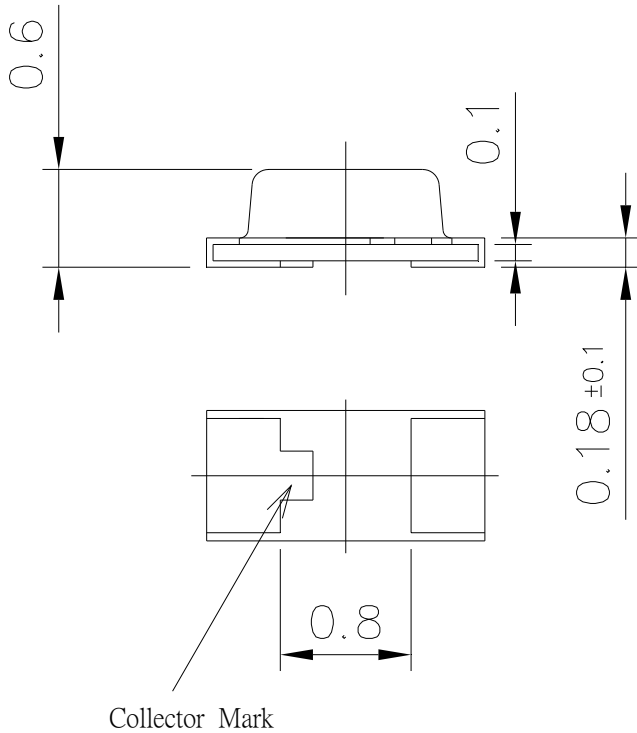
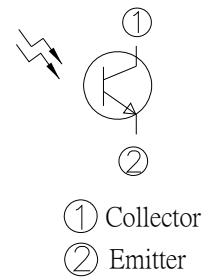
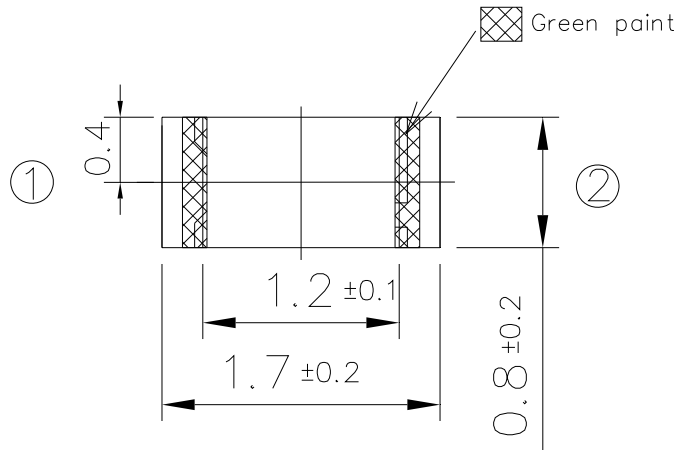

**Bottom View**

For reflow soldering (proposal)

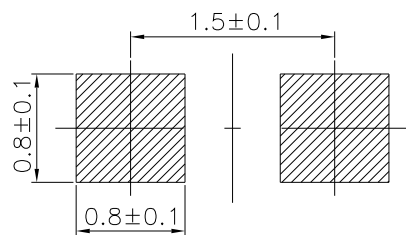

**Unit : mm**  
**Tolerances : ±0.1mm**

### Absolute Maximum Ratings

Parameter	Symbol	Rating	Unit
Supply Voltage	V <sub>cc</sub>	-0.5~6.0	V
Operating Temperature Range	T <sub>opr</sub>	-40 ~ +85	°C
Storage Temperature Range	T <sub>stg</sub>	-40 ~ +100	°C
Soldering Temperature Range <a href="#">[Note1]</a>	T <sub>sol</sub>	260 ± 10	°C

**Note1:** For detail reflow time and the recommended temperature profile, please refer to page 8.

### Recommended Operating Conditions

Parameter	Symbol	Min.	Max.	Unit
Operating Temperature	T <sub>opr</sub>	-40	+85	°C
Supply Voltage	V <sub>cc</sub>	2.5	5.5	V

Electrical and Optical Characteristics ( $T_a=25^{\circ}\text{C}$ )

Parameter	Symbol	MIN.	TYP.	MAX.	Unit	Test Condition
Dark Current	$I_{\text{CEO}}$	---	---	0.1	$\mu\text{A}$	$V_{\text{CE}}=10\text{V}$ , $E_v=0\text{Lux}$
Collector-Emitter Saturation Voltage	$V_{\text{CE(sat)}}$	---	---	0.4	V	$I_c=2\text{mA}$ , $E_v=1000\text{Lux}$
Light Current	$I_{\text{PH1}}$	5	15	---	$\mu\text{A}$	$V_{\text{CE}}=5\text{V}$ , $E_v=100\text{Lx}$ [Note1]
	$I_{\text{PH2}}$	50	150	---	$\mu\text{A}$	$V_{\text{CE}}=5\text{V}$ , $E_v=1000\text{Lx}$ [Note1]
	$I_{\text{PH3}}$	140	520	---	$\mu\text{A}$	$V_{\text{CE}}=5\text{V}$ , $E_v=1000\text{Lx}$ [Note2]
Photocurrent Ratio	$I_{\text{PH3}} / I_{\text{PH2}}$	---	3.5	---	---	$V_{\text{CE}}=5\text{V}$ , $E_v=1000\text{Lx}$
Saturation Output Voltage	$V_o$	4.5	4.6	---	V	$V_{\text{CC}}=5\text{V}$ , $E_v=1000\text{Lx}$ $R_L=75\text{K}$ [Note2]
Peak Sensitivity Wavelength	$\lambda_p$	---	630	---	nm	---
Sensitivity Wavelength Range	$\lambda$	390	---	700	nm	---
Rise time	$t_r$	---	0.11	---	ms	$V_{\text{CC}} = 5\text{V}$ $R_L = 7.5\text{K}\Omega$
Fall time	$t_f$	---	0.22	---	ms	

Note:

1. White Fluorescent light (Color Temperature = 6500K) is used as light source. However, White LED is substituted in mass production.
2. Illuminance by CIE standard illuminant-A / 2856K, incandescent lamp.

Typical Electrical and Optical Characteristics Curves

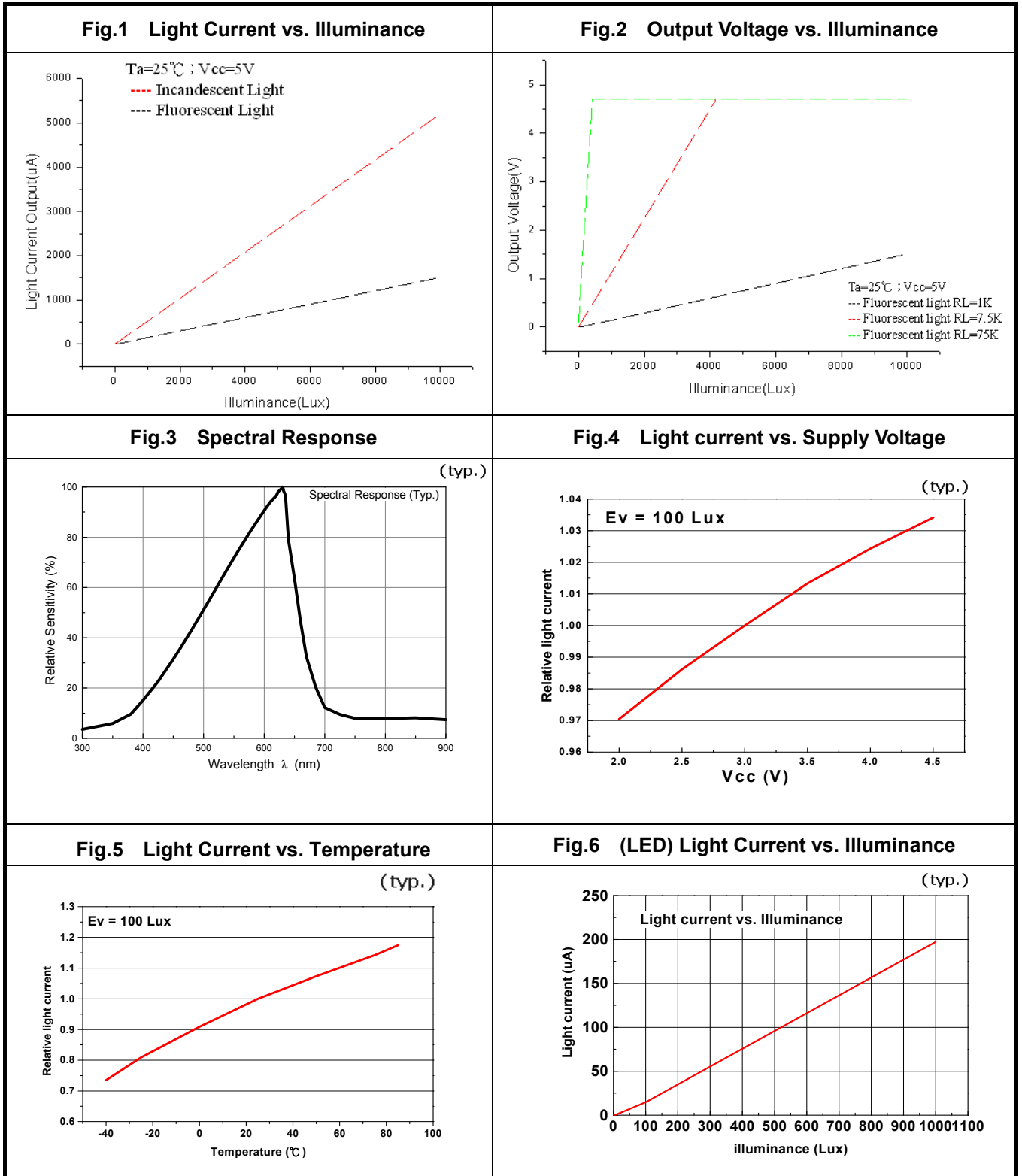

## Converting Photocurrent to Voltage

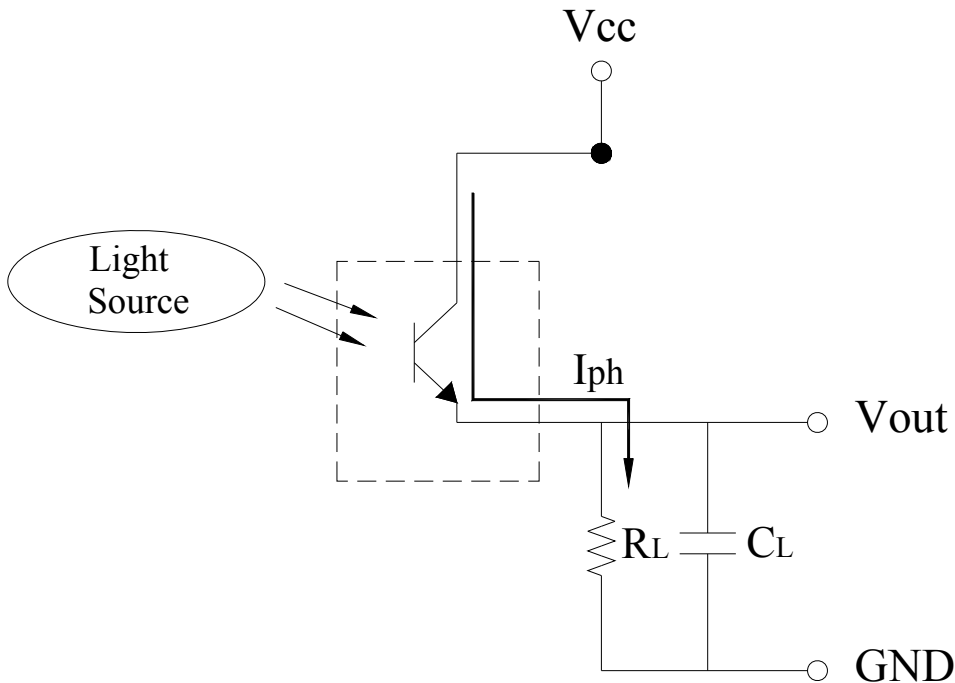

### Note:

1. The output voltage ( $V_{out}$ ) is the product of photocurrent ( $I_{PH}$ ) and loading resistor ( $R_L$ )
2. A right loading resistor shall be chosen to meet the requirement of maximum ambient light, and output saturation voltage:

$$V_{out(max.)} = I_{PH(max.)} \times R_L \leq V_{out(saturation)} = V_{cc} - 0.4V$$

$$R_L \times C_L \geq 0.5 \quad (\text{empirical data})$$

## **Recommended method of storage**

1. Do not open moisture proof bag before devices are ready to use.
2. Shelf life in sealed bag from the bag seal date: 18 months at 10°C~30°C and < 90% RH.
3. After opening the package, the devices must be stored at 10°C~30°C and ≤ 60%RH, and used within 168 hours (floor life).
4. If the moisture absorbent material (desiccant material) has faded or unopened bag has exceeded the shelf life or devices (out of bag) have exceeded the floor life, baking treatment is required.
5. If baking is required, refer to IPC/JEDEC J-STD-033 for bake procedure or recommend the following conditions:
  - 192 hours at 40°C +5/-0°C and < 5 % RH (reeled/tubed/loose units) or
  - 96 hours at 60°C ± 5°C and < 5 % RH (reeled/tubed/loose units) or
  - 24 hours at 125°C ± 5°C, not suitable for reel or tubes.

## **ESD Precaution:**

Proper storage and handling procedures should be followed to prevent ESD damage to the devices especially when they are removed from the Anti-static bag. Electro-Static Sensitive Devices warning labels are on the packing.

## Recommended Solder Profile

### 1. Soldering Condition

#### 1.1 (A) Maximum Body Case Temperature Profile for evaluation of Reflow Profile

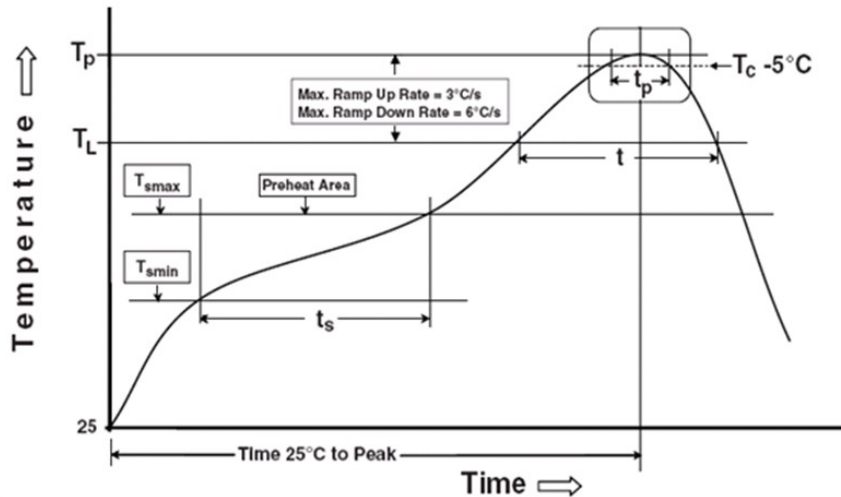

Note:

Reference: IPC/JEDEC J-STD-020D

#### Preheat

Temperature min ( $T_{smin}$ )	150 °C
Temperature max ( $T_{smax}$ )	200°C
Time ( $T_{smin}$ to $T_{smax}$ ) ( $t_s$ )	60-120 seconds
Average ramp-up rate ( $T_{smax}$ to $T_p$ )	3 °C/second max

#### Other

Liquidus Temperature ( $T_L$ )	217 °C
Time above Liquidus Temperature ( $t_L$ )	60-100 sec
Peak Temperature ( $T_p$ )	260°C
Time within 5 °C of Actual Peak Temperature: $T_p - 5^\circ\text{C}$	30 s
Ramp- Down Rate from Peak Temperature	6°C /second max.
Time 25°C to peak temperature	8 minutes max.
Reflow times	3 times

Notice:

- (1) When soldering, do not put stress on the devices during heating.
- (2) After soldering, do not warp the circuit board.

## Soldering Iron

Each terminal is to go to the tip of soldering iron temperature less than 350°C for 3 seconds within once in less than the soldering iron capacity 25W. Leave two seconds and more intervals, and do soldering of each terminal. Be careful because the damage of the product is often started at the time of the hand solder.

## Repairing

Repair should not be done after the device have been soldered. When repairing is unavoidable, a double-head soldering iron should be used (as below figure). It should be confirmed beforehand whether the characteristics of the device will or will not be damaged by repairing.

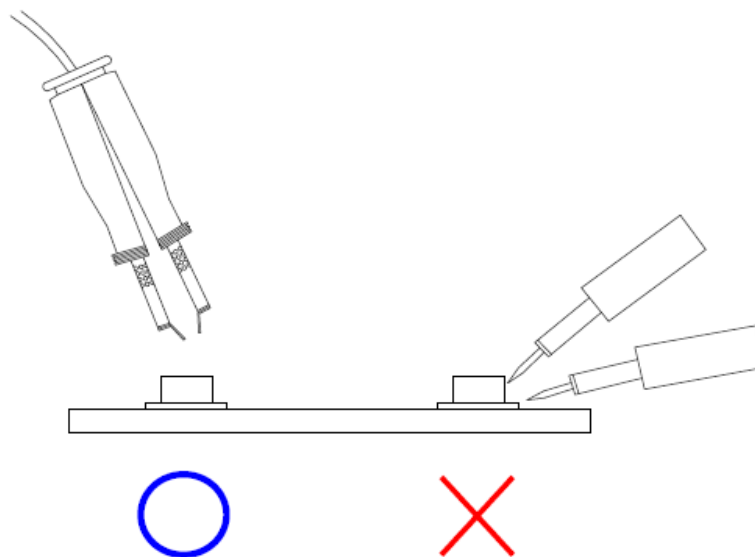

### Packing Quantity Specification

4000 PCS/ 1 Reel

### Label Format

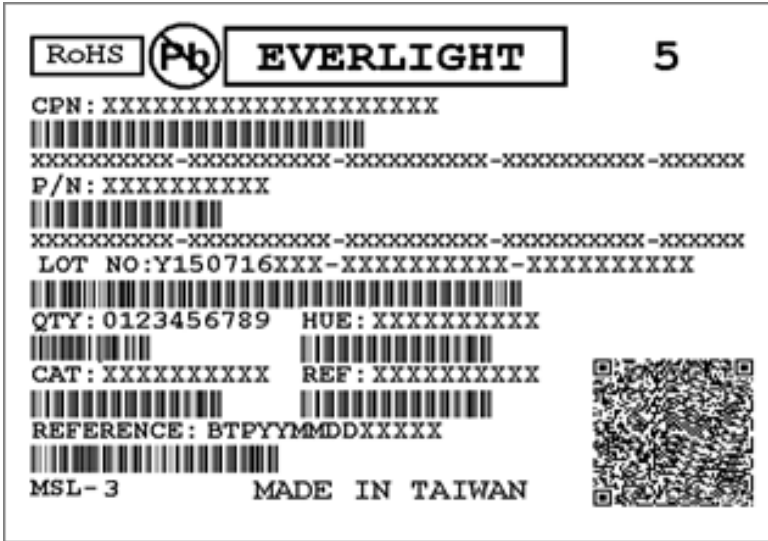

**Reel Dimensions**

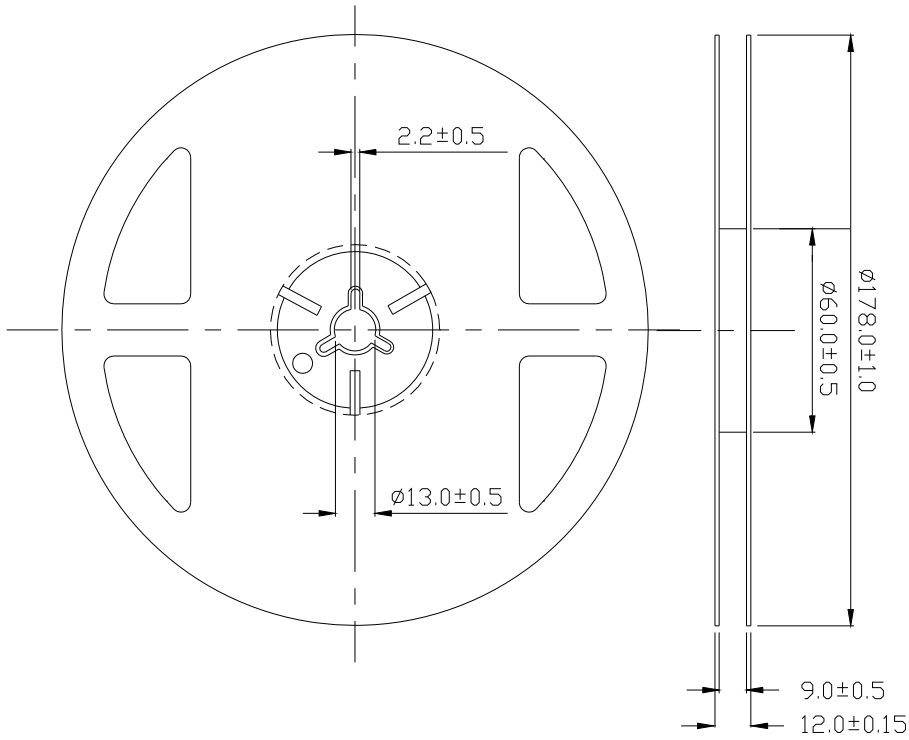

Unit: mm  
 Tolerance:  $\pm 0.1$ mm

**Tape Dimensions**

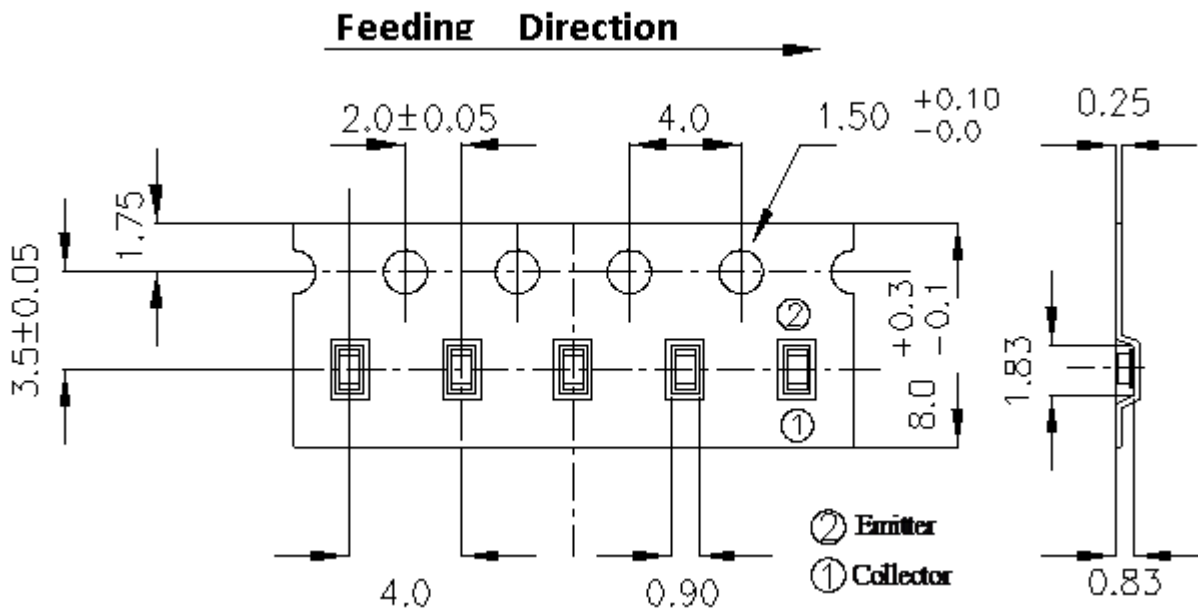

Unit: mm  
 Tolerance:  $\pm 0.1$ mm

## **DISCLAIMER**

1. EVERLIGHT reserves the right(s) on the adjustment of product material mix for the specification.
2. The product meets EVERLIGHT published specification for a period of twelve (12) months from date of shipment.
3. The graphs shown in this datasheet are representing typical data only and do not show guaranteed values.
4. When using this product, please observe the absolute maximum ratings and the instructions for using outlined in these specification sheets. EVERLIGHT assumes no responsibility for any damage resulting from the use of the product which does not comply with the absolute maximum ratings and the instructions included in these specification sheets.
5. These specification sheets include materials protected under copyright of EVERLIGHT. Reproduction in any form is prohibited without obtaining EVERLIGHT's prior consent.
6. This product is not intended to be used for military, aircraft, automotive, medical, life sustaining or life saving applications or any other application which can result in human injury or death. Please contact authorized Everlight sales agent for special application request.