



11AA010/11LC010    11AA080/11LC080  
 11AA020/11LC020    11AA160/11LC160  
 11AA040/11LC040    11AA161/11LC161

# 1-Kbit to 16-Kbit UNI/O<sup>®</sup> Serial EEPROM Family Data Sheet

## Features

- Single I/O, UNI/O<sup>®</sup> Serial Interface Bus
- Low-Power CMOS Technology:
  - 1 mA active current, typical
  - 1  $\mu$ A standby current (max.) (I-temp)
- 128 x 8 through 2,048 x 8 Bit Organizations
- Schmitt Trigger Inputs for Noise Suppression
- Output Slope Control to Eliminate Ground Bounce
- 100 kbps Max. Bit Rate – Equivalent to 100 kHz Clock Frequency
- Self-Timed Write Cycle (including Auto-Erase)
- Page-Write Buffer for up to 16 Bytes
- STATUS Register for Added Control:
  - Write enable latch bit
  - Write-In-Progress bit
- Block Write Protection:
  - Protect none, 1/4, 1/2 or all of array
- Built-in Write Protection:
  - Power-on/off data protection circuitry
  - Write enable latch
- High Reliability:
  - Endurance: 1,000,000 erase/write cycles
  - Data retention: > 200 years
  - ESD protection: > 4,000V
- RoHS Compliant
- Available Temperature Ranges:
  - Industrial (I): -40°C to +85°C
  - Extended (E): -40°C to +125°C
- Automotive AEC-Q100 Qualified

## Packages

- 3-lead SOT-23 and TO-92 Packages
- 4-lead Chip Scale Package
- 8-lead PDIP, SOIC, MSOP and TDFN Packages

## Pin Function Table

Name	Function
SCIO	Serial Clock, Data Input/Output
Vss	Ground
Vcc	Supply Voltage

## Description

The Microchip Technology Inc. 11AAXXX/11LCXXX (11XX<sup>(1)</sup>) devices are a family of 1-Kbit through 16-Kbit Serial Electrically Erasable PROMs. The devices are organized in blocks of x8-bit memory and support the patented<sup>(2)</sup> single I/O UNI/O<sup>®</sup> serial bus. By using Manchester encoding techniques, the clock and data are combined into a single, serial bit stream (SCIO), where the clock signal is extracted by the receiver to correctly decode the timing and value of each bit.

Low-voltage design permits operation down to 1.8V (for 11AAXXX devices), with standby and active currents of only 1  $\mu$ A and 1 mA, respectively.

**Note 1:** 11XX is used in this document as a generic part number for the 11 series devices.

**2:** Microchip's UNI/O<sup>®</sup> Bus products are covered by some or all of the following patents issued in the U.S.A.: 7,376,020 & 7,788,430.

## Package Types (not to scale)

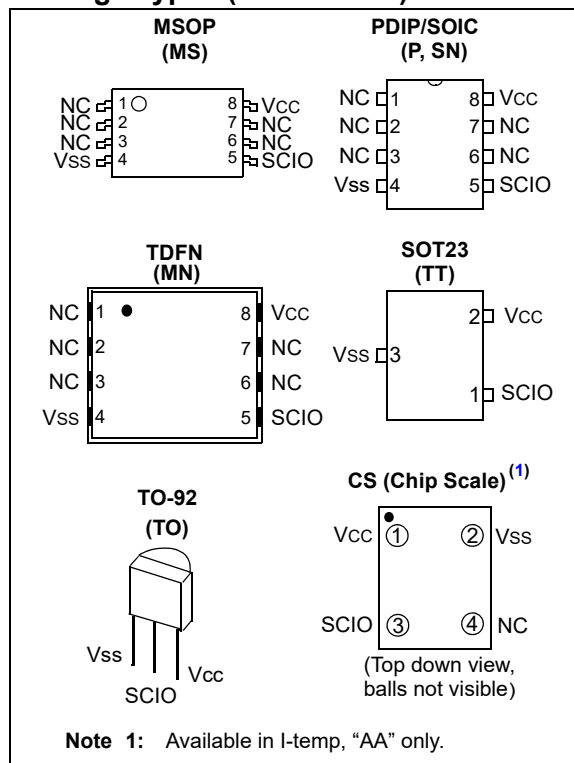

# 11AAXX/11LCXX

## DEVICE SELECTION TABLE

Part Number	Density (bits)	Organization	Vcc Range	Page Size (Bytes)	Temp. Ranges	Device Address	Packages
11LC010	1 Kbit	128 x 8	2.5V-5.5V	16	I,E	0xA0	P, SN, MS, MN, TO, TT
11AA010	1 Kbit	128 x 8	1.8V-5.5V	16	I	0xA0	P, SN, MS, MN, TO, TT, CS
11LC020	2 Kbit	256 x 8	2.5V-5.5V	16	I,E	0xA0	P, SN, MS, MN, TO, TT
11AA020	2 Kbit	256 x 8	1.8V-5.5V	16	I	0xA0	P, SN, MS, MN, TO, TT, CS
11LC040	4 Kbit	512 x 8	2.5V-5.5V	16	I,E	0xA0	P, SN, MS, MN, TO, TT
11AA040	4 Kbit	512 x 8	1.8V-5.5V	16	I	0xA0	P, SN, MS, MN, TO, TT, CS
11LC080	8 Kbit	1,024 x 8	2.5V-5.5V	16	I,E	0xA0	P, SN, MS, MN, TO, TT
11AA080	8 Kbit	1,024 x 8	1.8V-5.5V	16	I	0xA0	P, SN, MS, MN, TO, TT, CS
11LC160	16 Kbit	2,048 x 8	2.5V-5.5V	16	I,E	0xA0	P, SN, MS, MN, TO, TT
11AA160	16 Kbit	2,048 x 8	1.8V-5.5V	16	I	0xA0	P, SN, MS, MN, TO, TT,CS
11LC161	16 Kbit	2,048 x 8	2.5V-5.5V	16	I, E	0xA1	P, SN, MS, MN, TO, TT
11AA161	16 Kbit	2,048 x 8	1.8V-5.5V	16	I	0xA1	P, SN, MS, MN, TO, TT, CS

## 1.0 ELECTRICAL CHARACTERISTICS

### Absolute Maximum Ratings (†)

V <sub>CC</sub> .....	6.5V
SCIO w.r.t. V <sub>SS</sub> .....	-0.6V to V <sub>CC</sub> +1.0V
Storage temperature .....	-65°C to 150°C
Ambient temperature under bias.....	-40°C to 125°C
ESD protection on all pins.....	4 kV

† NOTICE: Stresses above those listed under ‘Absolute Maximum Ratings’ may cause permanent damage to the device. This is a stress rating only and functional operation of the device at those or any other conditions above those indicated in the operational listings of this specification is not implied. Exposure to maximum rating conditions for an extended period of time may affect device reliability.

**TABLE 1-1: DC CHARACTERISTICS**

DC CHARACTERISTICS			Electrical Characteristics:			
			Industrial (I):		Extended (E):	
Param. No.	Sym.	Characteristic	Min.	Max.	Units	Test Conditions
D1	V <sub>IH</sub>	High-level input voltage	0.7*V <sub>CC</sub>	V <sub>CC</sub> +1	V	—
D2	V <sub>IL</sub>	Low-level input voltage	-0.3	0.3*V <sub>CC</sub>	V	V <sub>CC</sub> ≥ 2.5V
			-0.3	0.2*V <sub>CC</sub>	V	V <sub>CC</sub> < 2.5V
D3	V <sub>HYS</sub>	Hysteresis of Schmitt Trigger inputs (SCIO)	0.05*V <sub>CC</sub>	—	V	V <sub>CC</sub> ≥ 2.5V ( <b>Note 1</b> )
D4	V <sub>OH</sub>	High-level output voltage	V <sub>CC</sub> -0.5	—	V	I <sub>OH</sub> = -300 μA, V <sub>CC</sub> = 5.5V
			V <sub>CC</sub> -0.5	—	V	I <sub>OH</sub> = -200 μA, V <sub>CC</sub> = 2.5V
D5	V <sub>OL</sub>	Low-level output voltage	—	0.4	V	I <sub>OL</sub> = 300 μA, V <sub>CC</sub> = 5.5V
			—	0.4	V	I <sub>OL</sub> = 200 μA, V <sub>CC</sub> = 2.5V
D6	I <sub>O</sub>	Output current limit ( <b>Note 2</b> )	—	±4	mA	V <sub>CC</sub> = 5.5V ( <b>Note 1</b> )
			—	±3	mA	V <sub>CC</sub> = 2.5V ( <b>Note 1</b> )
D7	I <sub>LI</sub>	Input leakage current (SCIO)	—	±1	μA	V <sub>IN</sub> = V <sub>SS</sub> or V <sub>CC</sub>
D8	C <sub>INT</sub>	Internal Capacitance (all inputs and outputs)	—	7	pF	T <sub>A</sub> = 25°C, F <sub>CLK</sub> = 1 MHz, V <sub>CC</sub> = 5.0V ( <b>Note 1</b> )
D9	I <sub>CC</sub> Read	Read Operating Current	—	3	mA	V <sub>CC</sub> =5.5V; F <sub>BUS</sub> =100 kHz, C <sub>B</sub> =100 pF
			—	1	mA	V <sub>CC</sub> =2.5V; F <sub>BUS</sub> =100 kHz, C <sub>B</sub> =100 pF
D10	I <sub>CC</sub> Write	Write Operating Current	—	5	mA	V <sub>CC</sub> = 5.5V
			—	3	mA	V <sub>CC</sub> = 2.5V
D11	I <sub>CCS</sub>	Standby Current	—	5	μA	V <sub>CC</sub> = 5.5V T <sub>A</sub> = 125°C
			—	1	μA	V <sub>CC</sub> = 5.5V T <sub>A</sub> = 85°C
D12	I <sub>CCI</sub>	Idle Mode Current	—	50	μA	V <sub>CC</sub> = 5.5V

**Note 1:** This parameter is periodically sampled and is not 100% tested.

**2:** The SCIO output driver impedance will vary to ensure I<sub>O</sub> is not exceeded.

# 11AAXX/11LCXX

**TABLE 1-2: AC CHARACTERISTICS**

AC CHARACTERISTICS			Electrical Characteristics:			
			Industrial (I):		VCC = 2.5V to 5.5V	TA = -40°C to +85°C
					VCC = 1.8V to 2.5V	TA = -20°C to +85°C
			Extended (E):		VCC = 2.5V to 5.5V	TA = -40°C to +125°C
Param. No.	Sym.	Characteristic	Min.	Max.	Units	Test Conditions
1	FBUS	Serial bus frequency	10	100	kHz	—
2	TE	Bit period	10	100	μs	—
3	TIJIT	Input edge jitter tolerance	—	±0.06	UI	(Note 2)
4	FDRIFT	Serial bus frequency drift rate tolerance	—	±0.50	% per byte	—
5	FDEV	Serial bus frequency drift limit	—	±5	% per command	—
6	TOJIT	Output edge jitter	—	±0.25	UI	(Note 2)
7	TR	SCIO input rise time (Note 1)	—	100	ns	—
8	TF	SCIO input fall time (Note 1)	—	100	ns	—
9	TSTBY	Standby pulse time	600	—	μs	—
10	TSS	Start header setup time	10	—	μs	—
11	THDR	Start header low pulse time	5	—	μs	—
12	TSP	Input filter spike suppression (SCIO)	—	50	ns	(Note 1)
13	TWC	Write cycle time (byte or page)	—	5	m	Write, WRSR commands
			—	10	ms	ERAL, SETAL commands
14	—	Endurance (per page)	1M	—	cycles	25°C, VCC = 5.5V

**Note 1:** This parameter is periodically sampled and is not 100% tested.

**Note 2:** A Unit Interval (UI) is equal to 1-bit period (TE) at the current bus frequency.

**Note 3:** This parameter is not tested but ensured by characterization.

**TABLE 1-3: AC TEST CONDITIONS**

AC Waveform:	
VLO = 0.2V	
VHI = VCC - 0.2V	
CL = 100 pF	
Timing Measurement Reference Level	
Input	0.5 VCC
Output	0.5 VCC

**FIGURE 1-1: BUS TIMING – START HEADER**

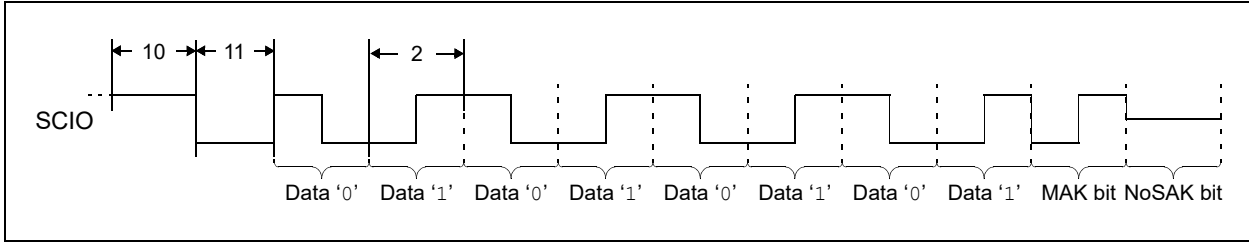

**FIGURE 1-2: BUS TIMING – DATA**

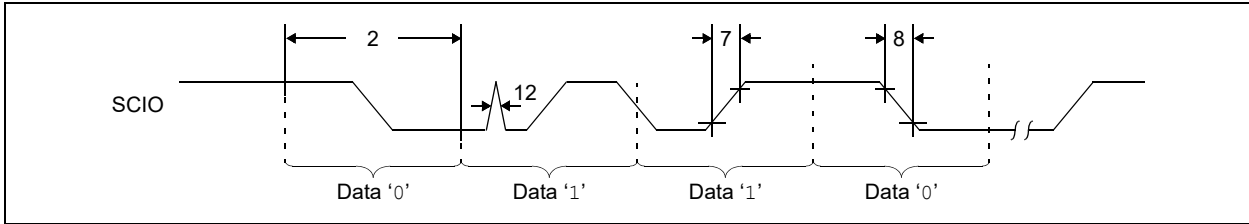

**FIGURE 1-3: BUS TIMING – STANDBY PULSE**

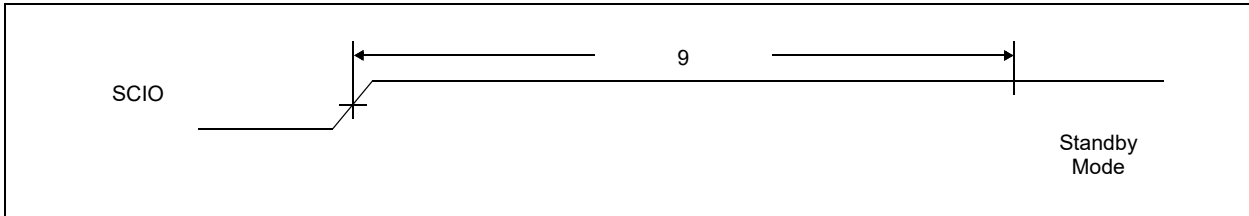

**FIGURE 1-4: BUS TIMING – JITTER**

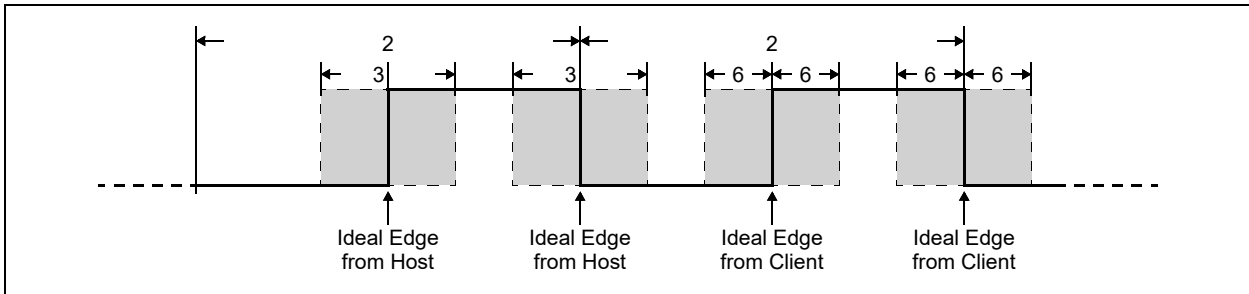

# 11AAXX/11LCXX

---

---

## 2.0 PIN DESCRIPTIONS

The descriptions of the pins are listed in [Table 2-1](#).

**TABLE 2-1: PIN FUNCTION TABLE**

Name	3-pin SOT-23	3-pin TO-92	4-pin CS	8-pin PDIP/SOIC/ MSOP/TDFN	Description
SCIO	1	2	3	5	Serial Clock, Data Input/Output
Vcc	2	3	1	8	Supply Voltage
Vss	3	1	2	4	Ground
NC	—	—	4	1,2,3,6,7	No Internal Connection

### 2.1 Serial Clock, Data Input/Output (SCIO)

SCIO is a bidirectional pin used to transfer commands and addresses into, as well as data into and out of, the device. The serial clock is embedded into the data stream through Manchester encoding. Each bit is represented by a signal transition at the middle of the bit period.

## 3.0 FUNCTIONAL DESCRIPTION

### 3.1 Principles of Operation

The 11AAXXX/11LCXXX family of serial EEPROMs support the UNI/O<sup>®</sup> protocol. They can be interfaced with microcontrollers, including Microchip's PIC<sup>®</sup> microcontrollers, ASICs, or any other device with an available discrete I/O line that can be configured properly to match the UNI/O protocol.

The 11AAXXX/11LCXXX devices contain an 8-bit instruction register. The devices are accessed via the SCIO pin.

Table 5-1 contains a list of the possible instruction bytes and format for device operation. All instructions, addresses, and data are transferred MSb first, LSB last.

Data is embedded into the I/O stream through Manchester encoding. The bus is controlled by a host device which determines the clock period, controls the bus access and initiates all operations, while the 11AAXXX/11LCXXX works as client. Both host and client can operate as transmitter or receiver, but the host device determines which mode is active.

**FIGURE 3-1: BLOCK DIAGRAM**

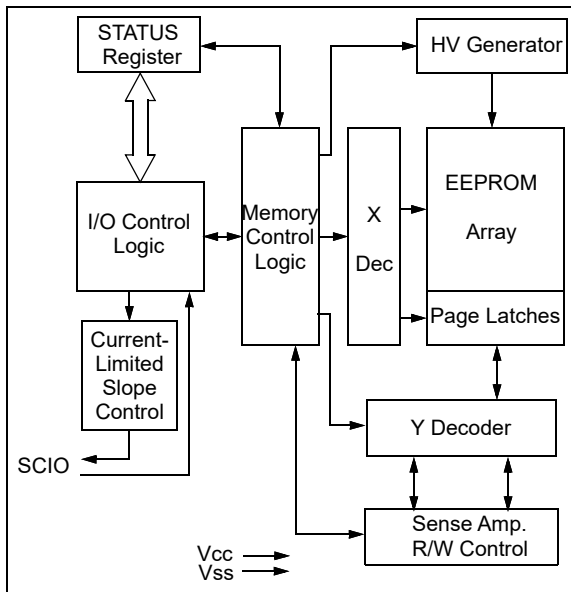

# 11AAXX/11LCXX

## 4.0 BUS CHARACTERISTICS

### 4.1 Standby Pulse

When the host has control of SCIO, a standby pulse can be generated by holding SCIO high for TSTBY. At this time, the 11AAXX/11LCXX will reset and return to Standby mode. Subsequently, a high-to-low transition on SCIO (the first low pulse of the header) will return the device to the active state.

Once a command is terminated satisfactorily (i.e., via a NoMAK/SAK combination during the Acknowledge sequence), performing a standby pulse is not required to begin a new command as long as the device to be selected is the same device selected during the previous command. However, a period of TSS must be observed after the end of the command and before the beginning of the start header. After TSS, the start header (including THDR low pulse) can be transmitted in order to begin the new command.

If a command is terminated in any manner other than a NoMAK/SAK combination, then the host must perform a standby pulse before beginning a new command, regardless of which device is to be selected.

**Note:** After a POR/BOR event occurs, a low-to-high transition on SCIO must be generated before proceeding with communication, including a standby pulse.

An example of two consecutive commands is shown in Figure 4-1. Note that the device address is the same for both commands, indicating that the same device is being selected both times.

A standby pulse cannot be generated while the client has control of SCIO. In this situation, the host must wait for the client to finish transmitting and to release SCIO before the pulse can be generated.

If, at any point during a command, an error is detected by the host, a standby pulse should be generated and the command should be performed again.

**FIGURE 4-1: CONSECUTIVE COMMANDS EXAMPLE**

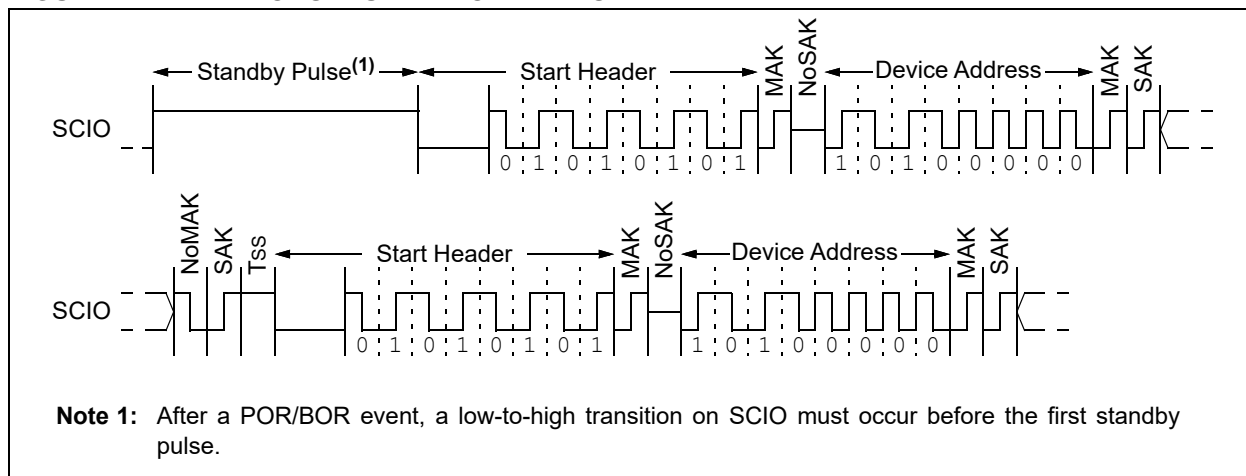

### 4.2 Start Data Transfer

All operations must be preceded by a start header. The start header consists of holding SCIO low for a period of THDR, followed by transmitting an 8-bit '01010101' code. This code is used to synchronize the client's internal clock period with the host's clock period, so accurate timing is very important.

When a standby pulse is not required (i.e., between successive commands to the same device), a period of TSS must be observed at the end of the command and before the beginning of the start header.

Figure 4-2 shows the waveform for the start header, including the required Acknowledge sequence at the end of the byte.

**FIGURE 4-2: START HEADER**

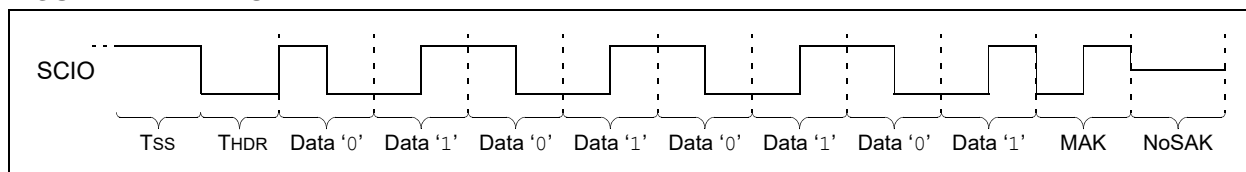

## 4.3 Acknowledge

An Acknowledge routine occurs after each byte is transmitted, including the start header. This routine consists of two bits. The first bit is transmitted by the host, and the second bit is transmitted by the client.

**Note:** A MAK must always be transmitted following the start header.

The Host Acknowledge, or MAK, is signified by transmitting a '1', and informs the client that the current operation is to be continued. Conversely, a Not Acknowledge, or NoMAK, is signified by transmitting a '0', and is used to end the current operation (and initiate the write cycle for write operations).

**Note:** When a NoMAK is used to end a WRITE or WRSR instruction, the write cycle is not initiated if no bytes of data have been received.

The Client Acknowledge, or SAK, is also signified by transmitting a '1', and confirms proper communication. However, unlike the NoMAK, the NoSAK is signified by the lack of a middle edge during the bit period.

**Note:** To guard against bus contention, a NoSAK will occur after the start header.

A NoSAK will occur for the following events:

- Following the start header
- Following the device address, if no client on the bus matches the transmitted address
- Following the command byte, if the command is invalid, including Read, CRRD, Write, WRSR, SETAL and ERAL during a write cycle.
- If the client becomes out of sync with the host
- If a command is terminated prematurely by using a NoMAK, with the exception of immediately after the device address.

See [Figure 4-3](#) and [Figure 4-4](#) for details.

If a NoSAK is received from the client after any byte (except the start header), an error has occurred. The host should then perform a standby pulse and begin the desired command again.

**FIGURE 4-3: ACKNOWLEDGE ROUTINE**

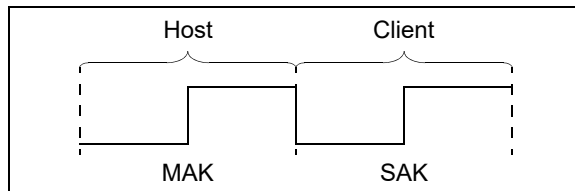

**FIGURE 4-4: ACKNOWLEDGE BITS**

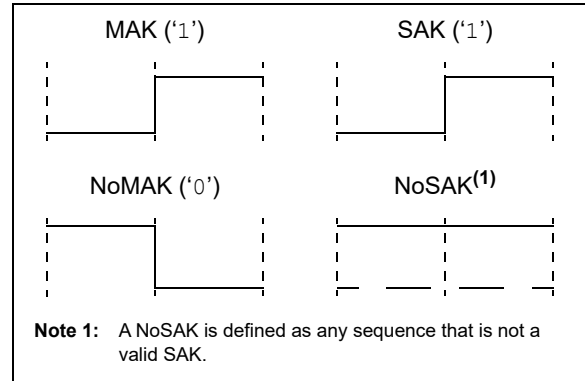

## 4.4 Device Addressing

A device address byte is the first byte received from the host device following the start header. The device address byte consists of a four-bit family code. For the 11AAXXX/11LCXXX, this is set as '1010'. The last four bits of the device address byte are the device code, which is hardwired to '0000' on the 11XXXX0 devices.

The device code on 11XXXX1 devices is hardwired to '0001'. This allows both 11XXXX0 and 11XXXX1 devices to be used on the same bus without address conflicts.

**FIGURE 4-5: DEVICE ADDRESS BYTE ALLOCATION**

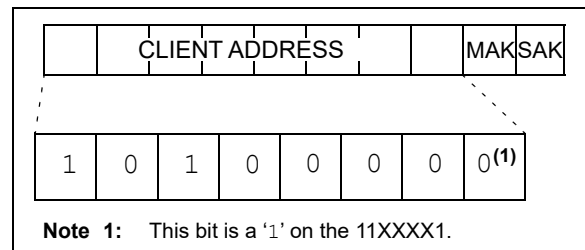

## 4.5 Bus Conflict Protection

To help guard against high current conditions arising from bus conflicts, the 11AAXXX/11LCXXX features a current-limited output driver. The IOL and IOH specifications describe the maximum current that can be sunk or sourced, respectively, by the SCIO pin. The 11AAXXX/11LCXXX will vary the output driver impedance to ensure that the maximum current level is not exceeded.

# 11AAXXX/11LCXXX

## 4.6 Device Standby

The 11AAXXX/11LCXXX features a low-power Standby mode during which the device is waiting to begin a new command. A high-to-low transition on SCIO will exit low-power mode and prepare the device for receiving the start header.

Standby mode will be entered upon the following conditions:

- A NoMAK followed by a SAK (i.e., valid termination of a command)
- Reception of a standby pulse

**Note:** In the case of the WRITE, WRSR, SETAL or ERAL commands, the write cycle is initiated upon receipt of the NoMAK, assuming all other write requirements have been met.

## 4.7 Device Idle

The 11AAXXX/11LCXXX features an Idle mode during which all serial data is ignored until a standby pulse occurs. Idle mode will be entered upon the following conditions:

- Invalid device address
- Invalid command byte, including Read, CRRD, Write, WRSR, SETAL and ERAL during a write cycle.
- Missed edge transition
- Reception of a MAK following a WREN, WRDI, SETAL or ERAL command byte
- Reception of a MAK following the data byte of a WRSR command

An invalid start header will indirectly cause the device to enter Idle mode. Whether or not the start header is invalid cannot be detected by the client, but will prevent the client from synchronizing properly with the host. If the client is not synchronized with the host, an edge transition will be missed, thus causing the device to enter Idle mode.

## 4.8 Synchronization

At the beginning of every command, the 11AAXXX/11LCXXX utilizes the start header to determine the host's bus clock period. This period is then used as a reference for all subsequent communication within that command.

The 11AAXXX/11LCXXX features re-synchronization circuitry, which will monitor the position of the middle data edge during each MAK bit and will subsequently adjust the internal time reference to remain synchronized with the host.

There are two variables which can cause the 11AAXXX/11LCXXX to lose synchronization. The first is frequency drift, defined as a change in the bit period,

TE. The second is edge jitter, which is a single occurrence change in the position of an edge within a bit period, while the bit period itself remains constant.

### 4.8.1 FREQUENCY DRIFT

Within a system, there is a possibility that frequencies can drift due to changes in voltage, temperature, etc. The re-synchronization circuitry provides some tolerance for such frequency drift. The tolerance range is specified by two parameters, FDRIFT and FDEV. FDRIFT specifies the maximum tolerable change in bus frequency per byte. FDEV specifies the overall limit in frequency deviation within an operation (i.e., from the end of the start header until communication is terminated for that operation). The start header at the beginning of the next operation will reset the re-synchronization circuitry and allow for another FDEV amount of frequency drift.

### 4.8.2 EDGE JITTER

Ensuring that edge transitions from the host always occur exactly in the middle or end of the bit period is not always possible. Therefore, the re-synchronization circuitry is designed to provide some tolerance for edge jitter.

The 11XX adjusts its phase every MAK bit, so TJIT specifies the maximum allowable peak-to-peak jitter relative to the previous MAK bit. Since the position of the previous MAK bit would be difficult to measure by the host, the minimum and maximum jitter values for a system should be considered the worst-case. These values will be based on the execution time for different branch paths in software, jitter due to thermal noise, etc.

The difference between the minimum and maximum values, as a percentage of the bit period, should be calculated and then compared against TJIT to determine jitter compliance.

**Note:** Because the 11AAXXX/11LCXXX only re-synchronizes during the MAK bit, the overall ability to remain synchronized depends on a combination of frequency drift and edge jitter (i.e., if the MAK bit edge is experiencing the maximum allowable edge jitter, then there is no room for frequency drift). Conversely, if the frequency has drifted to the maximum amount tolerable within a byte, then no edge jitter can be present.

## 5.0 DEVICE COMMANDS

After the device address byte, a command byte must be sent by the host to indicate the type of operation to be performed. The code for each instruction is listed in Table 5-1.

**TABLE 5-1: INSTRUCTION SET**

Instruction Name	Instruction Code	Hex Code	Description
READ	0000 0011	0x03	Read data from memory array beginning at specified address
CRRD	0000 0110	0x06	Read data from current location in memory array
WRITE	0110 1100	0x6C	Write data to memory array beginning at specified address
WREN	1001 0110	0x96	Set the write enable latch (enable write operations)
WRDI	1001 0001	0x91	Reset the write enable latch (disable write operations)
RDSR	0000 0101	0x05	Read STATUS register
WRSR	0110 1110	0x6E	Write STATUS register
ERAL	0110 1101	0x6D	Write '0x00' to entire array
SETAL	0110 0111	0x67	Write '0xFF' to entire array

### 5.1 Read Instruction

The Read command allows the host to access any memory location in a random manner. After the READ instruction has been sent to the client, the two bytes of the Word Address are transmitted, with an Acknowledge sequence being performed after each byte. Then, the client sends the first data byte to the host. If more data is to be read, the host sends a MAK, indicating that the client should output the next data byte. This continues until the host sends a NoMAK, which ends the operation.

To provide sequential reads in this manner, the 11AAXXX/11LCXXX contains an internal Address Pointer which is incremented by one after the transmission of each byte. This Address Pointer allows the memory contents to be serially read during one operation. When the highest address is reached, the Address Pointer rolls over to address '0x000' if the host chooses to continue the operation by providing a MAK.

**FIGURE 5-1: READ COMMAND SEQUENCE**

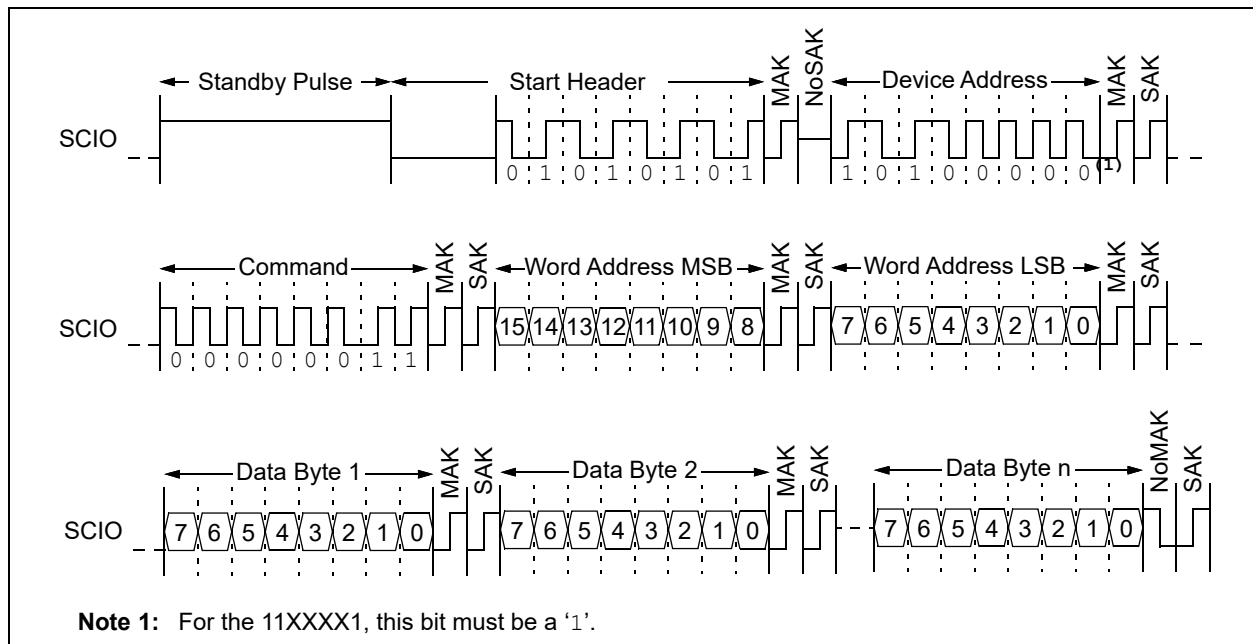

# 11AAXXX/11LCXXX

## 5.2 Current Address Read (CRRD) Instruction

The internal address counter featured on the 11AAXXX/11LCXXX maintains the address of the last memory array location accessed. The CRRD instruction allows the host to read data back beginning from this current location. Consequently, no word address is provided upon issuing this command.

Note that, except for the initial word address, the READ and CRRD instructions are identical, including the ability to continue requesting data through the use of MAKs in order to sequentially read from the array.

As with the READ instruction, the CRRD instruction is terminated by transmitting a NoMAK.

Table 5-2 lists the events upon which the internal address counter is modified.

**TABLE 5-2: INTERNAL ADDRESS COUNTER**

Command	Event	Action
—	Power-on Reset	Counter is undefined
READ or WRITE	MAK edge following each Address byte	Counter is updated with newly received value
READ, WRITE or CRRD	MAK/NoMAK edge following each data byte	Counter is incremented by 1

**Note 1:** If, following each data byte in a READ, WRITE or CRRD instruction, neither a MAK nor a NoMAK edge is received (i.e., if a standby pulse occurs instead), the internal address counter will not be incremented.

**2:** During a Write command, once the last data byte for a page has been loaded, the internal Address Pointer will rollover to the beginning of the selected page.

**FIGURE 5-2: CRRD COMMAND SEQUENCE**

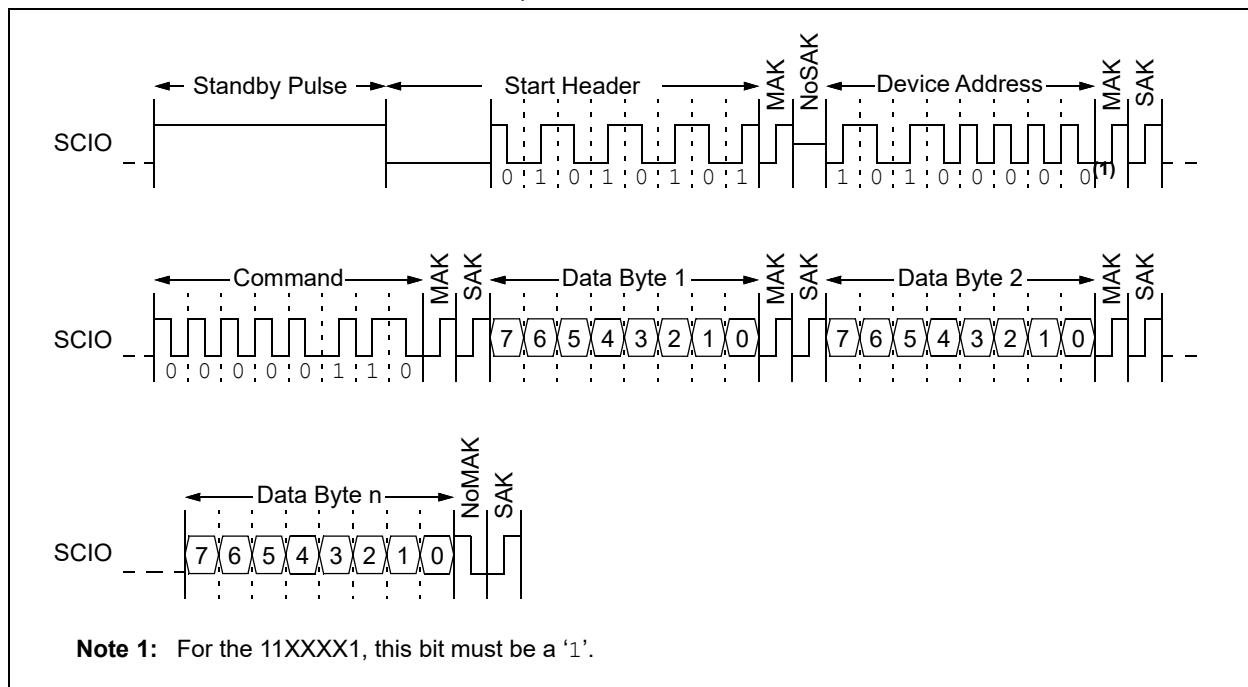

## 5.3 Write Instruction

Prior to any attempt to write data to the 11AAXXX/11LCXXX, the write enable latch must be set by issuing the WREN instruction (see [Section 5.4 “Write Enable \(WREN\) and Write Disable \(WRDI\) Instructions”](#)).

Once the write enable latch is set, the user may proceed with issuing a WRITE instruction (including the header and device address bytes) followed by the MSB and LSB of the Word Address. Once the last Acknowledge sequence has been performed, the host transmits the data byte to be written.

The 11AAXXX/11LCXXX features a 16-byte page buffer, meaning that up to 16 bytes can be written at one time. To utilize this feature, the host can transmit up to 16 data bytes to the 11AAXXX/11LCXXX, which are temporarily stored in the page buffer. After each data byte, the host sends a MAK, indicating whether or not another data byte is to follow. A NoMAK indicates that no more data is to follow, and as such will initiate the internal write cycle.

**Note:** If a NoMAK is generated before any data has been provided, or if a standby pulse occurs before the NoMAK is generated, the 11AAXXX/11LCXXX will be reset, and the write cycle will not be initiated.

Upon receipt of each word, the four lower-order Address Pointer bits are internally incremented by one. The higher-order bits of the word address remain constant. If the host should transmit data past the end of the page, the address counter will roll over to the beginning of the page, where further received data will be written.

**Note:** Page write operations are limited to writing bytes within a single physical page, **regardless** of the number of bytes actually being written. Physical page boundaries start at addresses that are integer multiples of the page size (16 bytes) and end at addresses that are integer multiples of the page size minus 1. As an example, the page that begins at address 0x30 ends at address 0x3F. If a page Write command attempts to write across a physical page boundary, the result is that the data wraps around to the beginning of the current page (overwriting data previously stored there), instead of being written to the next page as might be expected. It is, therefore, necessary for the application software to prevent page write operations that would attempt to cross a page boundary.

**FIGURE 5-3: WRITE COMMAND SEQUENCE**

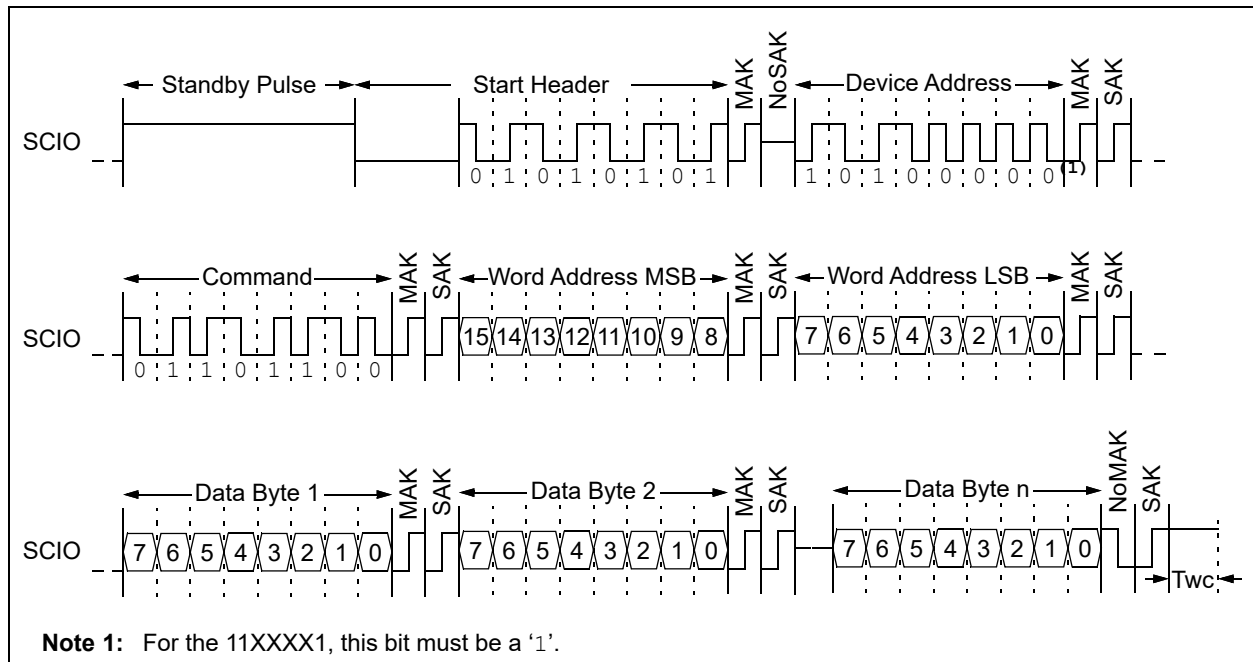

# 11AAXX/11LCXX

## 5.4 Write Enable (WREN) and Write Disable (WRDI) Instructions

The 11XX contains a write enable latch. See [Table 7-1](#) for the Write-Protect Functionality Matrix. This latch must be set before any write operation will be completed internally. The WREN instruction will set the latch, and the WRDI instruction will reset the latch.

**Note:** The WREN and WRDI instructions must be terminated with a NoMAK following the command byte. If a NoMAK is not received at this point, the command will be considered invalid, and the device will go into Idle mode without responding with a SAK or executing the command.

The following is a list of conditions under which the write enable latch will be reset:

- Power-up
- WRDI instruction successfully executed
- WRSR instruction successfully executed
- WRITE instruction successfully executed
- ERAL instruction successfully executed
- SETAL instruction successfully executed

**FIGURE 5-4: WRITE ENABLE COMMAND SEQUENCE**

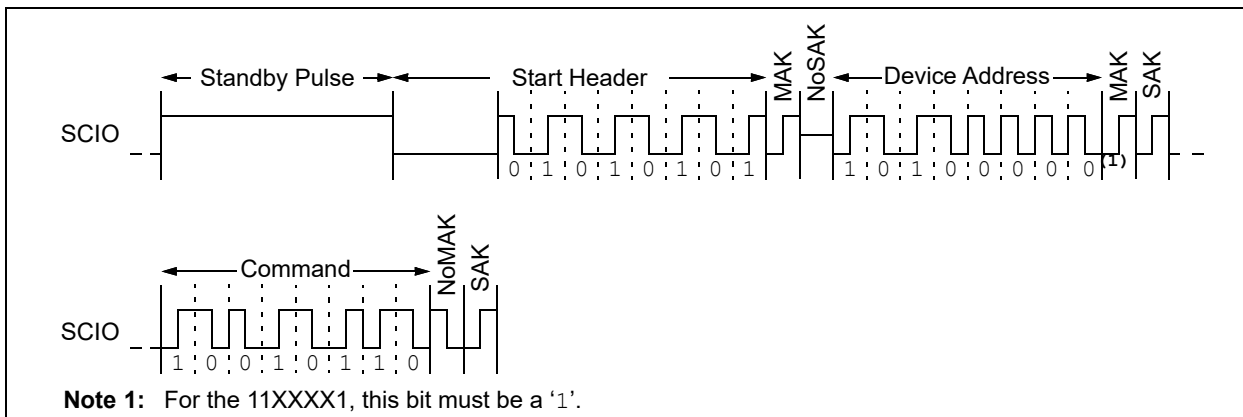

**FIGURE 5-5: WRITE DISABLE COMMAND SEQUENCE**

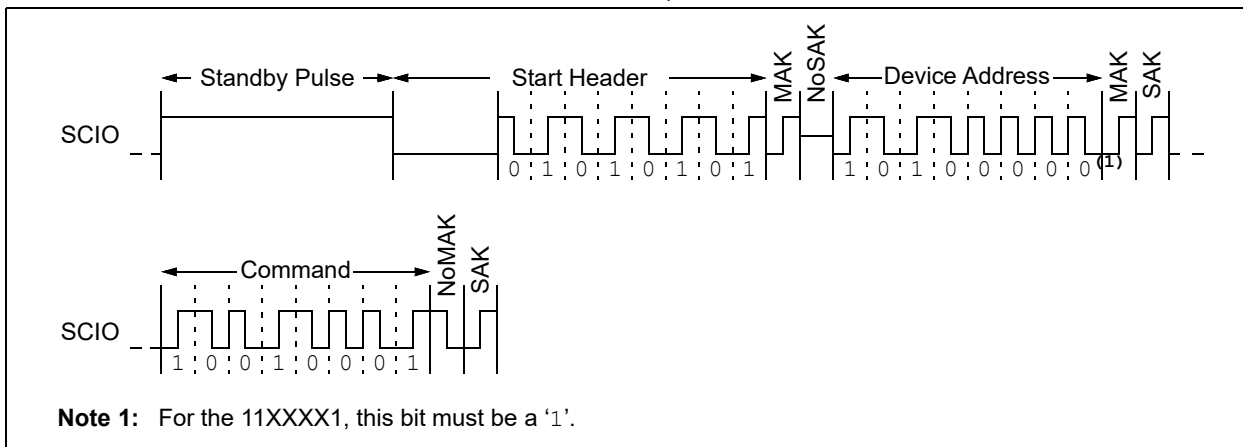

## 5.5 Read Status Register (RDSR) Instruction

The RDSR instruction provides access to the STATUS register. The STATUS register may be read at any time, even during a write cycle. The STATUS register is formatted as follows:

7	6	5	4	3	2	1	0
X	X	X	X	BP1	BP0	WEL	WIP

**Note:** Bits 4-7 are don't cares, and will read as '0'.

The **Write-In-Process (WIP)** bit indicates whether the 11AAXX/11LCXX is busy with a write operation. When set to a '1', a write is in progress. When set to a '0', no write is in progress. This bit is read-only.

The **Write Enable Latch (WEL)** bit indicates the status of the write enable latch. When set to a '1', the latch allows writes to the array. When set to a '0', the latch prohibits writes to the array. This bit is set and cleared using the WREN and WRDI instructions, respectively. This bit is read-only for any other instruction.

The **Block Protection (BP0 and BP1)** bits indicate which blocks are currently write-protected. These bits are set by the user through the WRSR instruction. These bits are nonvolatile.

**Note:** If Read Status Register command is initiated while the 11XX is currently executing an internal write cycle on the STATUS register, the new Block Protection bit values will be read during the entire command.

The WIP and WEL bits will update dynamically (asynchronous to issuing the RDSR instruction). Furthermore, after the STATUS register data is received, the host can provide a MAK during the Acknowledge sequence to request that the data be transmitted again. This allows the host to continuously monitor the WIP and WEL bits without the need to issue another full command.

Once the host is finished, it provides a NoMAK to end the operation.

**Note:** The current drawn for a Read Status Register command during a write cycle is a combination of the ICC Read and ICC Write operating currents.

**FIGURE 5-6: READ STATUS REGISTER COMMAND SEQUENCE**

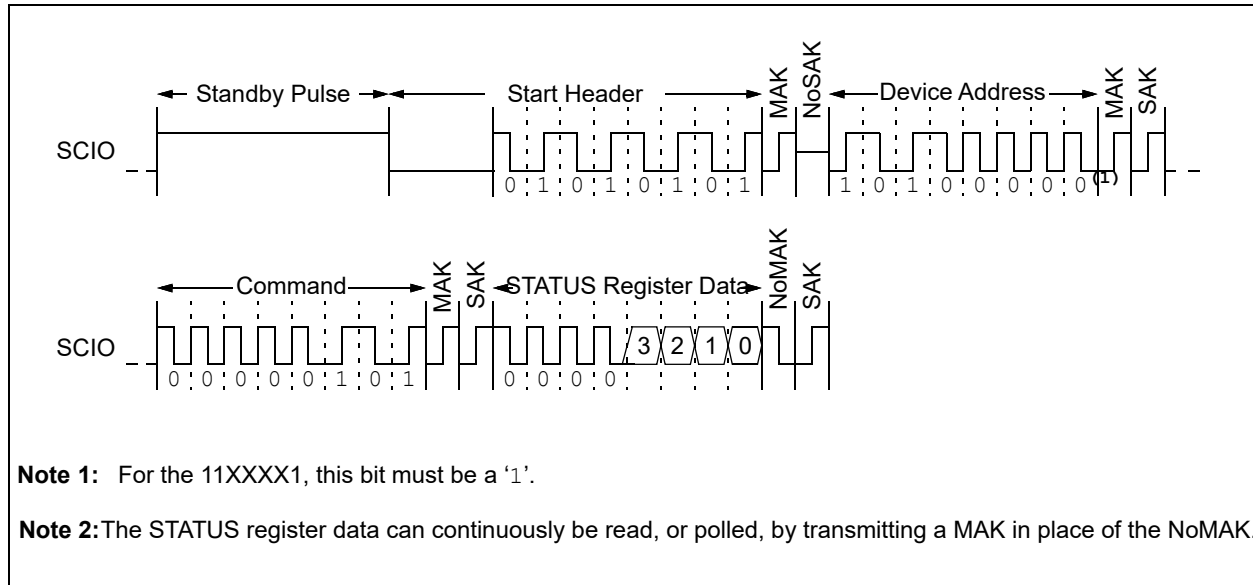

# 11AAXX/11LCXX

## 5.6 Write Status Register (WRSR) Instruction

The WRSR instruction allows the user to select one of four levels of protection for the array by writing to the appropriate bits in the STATUS register. The array is divided into four segments. The user has the ability to write-protect none, one, two, or all four of the segments of the array. The partitioning is controlled as illustrated in Table 5-3.

After transmitting the STATUS register data, the host must transmit a NoMAK during the Acknowledge sequence in order to initiate the internal write cycle.

**Note:** The WRSR instruction must be terminated with a NoMAK following the data byte. If a NoMAK is not received at this point, the command will be considered invalid, and the device will go into Idle mode without responding with a SAK or executing the command.

**TABLE 5-3: ARRAY PROTECTION**

BP1	BP0	Address Ranges Write-Protected	Address Ranges Unprotected
0	0	None	All
0	1	Upper 1/4	Lower 3/4
1	0	Upper 1/2	Lower 1/2
1	1	All	None

**TABLE 5-4: PROTECTED ARRAY ADDRESS LOCATIONS**

Density	Upper 1/4	Upper 1/2	All Sectors
1K	60h-7Fh	40h-7Fh	00h-7Fh
2K	C0h-FFh	80h-FFh	00h-FFh
4K	180h-1FFh	100h-1FFh	000h-1FFh
8K	300h-3FFh	200h-3FFh	000h-3FFh
16K	600h-7FFh	400h-7FFh	000h-7FFh

**FIGURE 5-7: WRITE STATUS REGISTER COMMAND SEQUENCE**

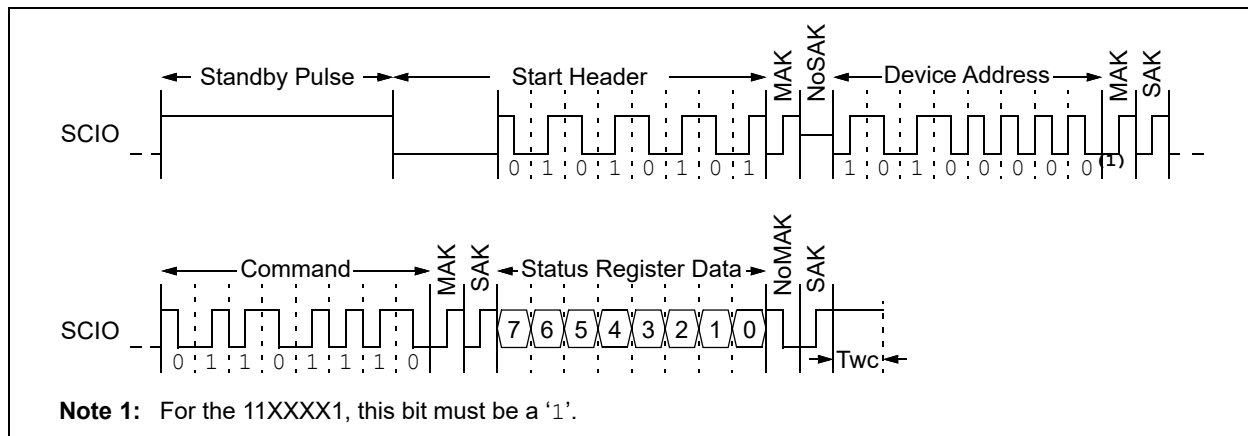

## 5.7 Erase All (ERAL) Instruction

The **ERAL** instruction allows the user to write '0x00' to the entire memory array with one command. Note that the write enable latch (WEL) must first be set by issuing the **WREN** instruction.

Once the write enable latch is set, the user may proceed with issuing a **ERAL** instruction (including the header and device address bytes). Immediately after the NoMAK bit has been transmitted by the host, the internal write cycle is initiated, during which time all words of the memory array are written to '0x00'.

The **ERAL** instruction is ignored if either of the Block Protect bits (BP0, BP1) are not 0, meaning 1/4, 1/2, or all of the array is protected.

**Note:** The **ERAL** instruction must be terminated with a NoMAK following the command byte. If a NoMAK is not received at this point, the command will be considered invalid, and the device will go into Idle mode without responding with a SAK or executing the command.

**FIGURE 5-8: ERASE ALL COMMAND SEQUENCE**

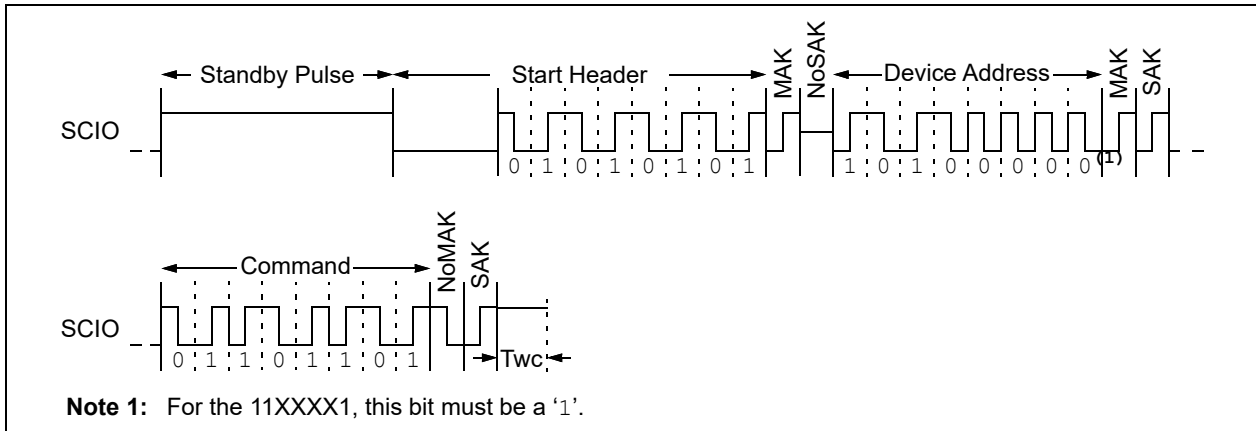

## 5.8 Set All (SETAL) Instruction

The **SETAL** instruction allows the user to write '0xFF' to the entire memory array with one command. Note that the write enable latch (WEL) must first be set by issuing the **WREN** instruction.

Once the write enable latch is set, the user may proceed with issuing a **SETAL** instruction (including the header and device address bytes). Immediately after the NoMAK bit has been transmitted by the host, the internal write cycle is initiated, during which time all words of the memory array are written to '0xFF'.

The **SETAL** instruction is ignored if either of the Block Protect bits (BP0, BP1) are not 0, meaning 1/4, 1/2, or all of the array is protected.

**Note:** The **SETAL** instruction must be terminated with a NoMAK following the command byte. If a NoMAK is not received at this point, the command will be considered invalid, and the device will go into Idle mode without responding with a SAK or executing the command.

**FIGURE 5-9: SET ALL COMMAND SEQUENCE**

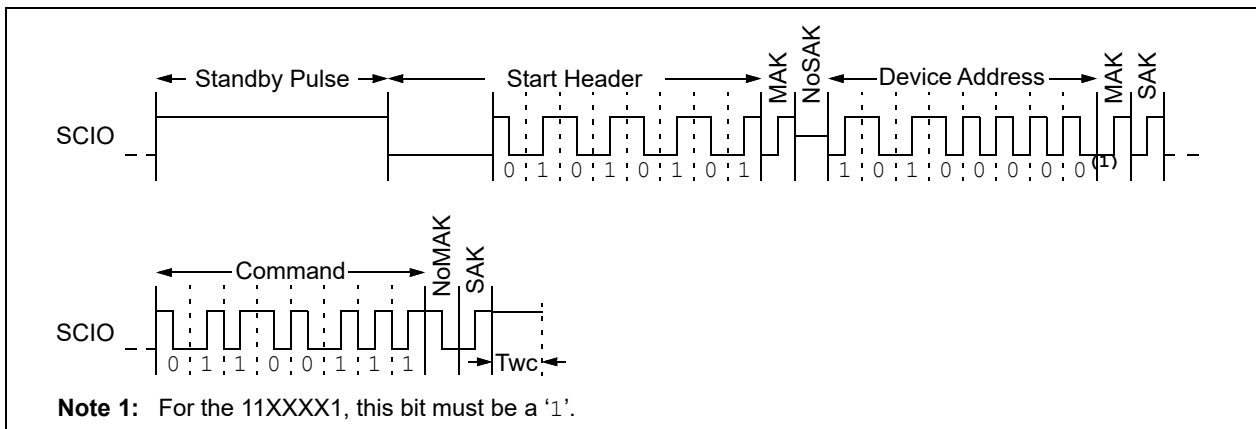

# 11AAXXX/11LCXXX

---

## 6.0 DATA PROTECTION

The following protection has been implemented to prevent inadvertent writes to the array:

- The Write Enable Latch (WEL) is reset on power-up
- A Write Enable (`WREN`) instruction must be issued to set the write enable latch
- After a write, `ERAL`, `SETAL` or `WRSR` command, the write enable latch is reset
- Commands to access the array or write to the `STATUS` register are ignored during an internal write cycle and programming is not affected

## 7.0 POWER-ON STATE

The 11AAXXX/11LCXXX powers on in the following state:

- The device is in low-power Shutdown mode, requiring a low-to-high transition on `SCIO` to enter Idle mode
- The Write Enable Latch (WEL) is reset
- The internal Address Pointer is undefined
- A low-to-high transition, standby pulse and subsequent high-to-low transition on `SCIO` (the first low pulse of the header) are required to enter the active state

**TABLE 7-1: WRITE PROTECT FUNCTIONALITY MATRIX**

<b>WEL</b>	<b>Protected Blocks</b>	<b>Unprotected Blocks</b>	<b>Status Register</b>
0	Protected	Protected	Protected
1	Protected	Writable	Writable

## 8.0 PACKAGING INFORMATION

### 8.1 Package Marking Information

8-Lead PDIP

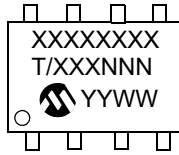

Example:

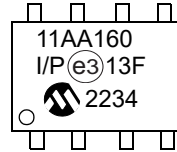

8-Lead PDIP Package Marking (Pb-Free)			
Device	Line 1 Marking	Device	Line 1 Marking
11AA010	11AA010	11LC010	11LC010
11AA020	11AA020	11LC020	11LC020
11AA040	11AA040	11LC040	11LC040
11AA080	11AA080	11LC080	11LC080
11AA160	11AA160	11LC160	11LC160
11AA161	11AA161	11LC161	11LC161

**Note:** T = Temperature Grade (I, E)

<b>Legend:</b>	XX...X	Part number or part number code
	T	Temperature (I, E)
	Y	Year code (last digit of calendar year)
	YY	Year code (last 2 digits of calendar year)
	WW	Week code (week of January 1 is week '01')
	NNN	Alphanumeric traceability code (2 characters for small packages)
	e3	RoHS-compliant JEDEC® designator for Matte Tin (Sn)

**Note:** Standard OTP marking consists of Microchip part number, year code, week code and traceability code.

**Note:** For very small packages with no room for the JEDEC® designator e3, the marking will only appear on the outer carton or reel label.

**Note:** In the event the full Microchip part number cannot be marked on one line, it will be carried over to the next line, thus limiting the number of available characters for customer-specific information.

# 11AAXX/11LCXX

8-Lead SOIC

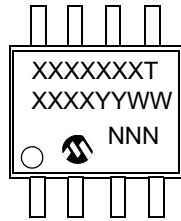

Example:

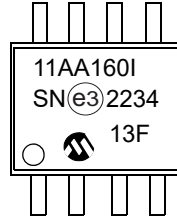

8-Lead SOIC Package Marking (Pb-Free)

Device	Line 1 Marking	Device	Line 1 Marking
11AA010	11AA010T	11LC010	11LC010T
11AA020	11AA020T	11LC020	11LC020T
11AA040	11AA040T	11LC040	11LC040T
11AA080	11AA080T	11LC080	11LC080T
11AA160	11AA160T	11LC160	11LC160T
11AA161	11AA161T	11LC161	11LC161T

**Note:** T = Temperature Grade (I, E)

<b>Legend:</b>	XX...X	Part number or part number code
	T	Temperature (I, E)
	Y	Year code (last digit of calendar year)
	YY	Year code (last 2 digits of calendar year)
	WW	Week code (week of January 1 is week '01')
	NNN	Alphanumeric traceability code (2 characters for small packages)
	(e3)	RoHS-compliant JEDEC® designator for Matte Tin (Sn)

**Note:** Standard OTP marking consists of Microchip part number, year code, week code and traceability code.

**Note:** For very small packages with no room for the JEDEC® designator (e3), the marking will only appear on the outer carton or reel label.

**Note:** In the event the full Microchip part number cannot be marked on one line, it will be carried over to the next line, thus limiting the number of available characters for customer-specific information.

# 11AAXXX/11LCXXX

8-Lead MSOP (150 mil)

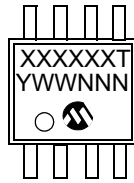

Example:

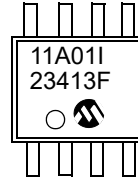

8-Lead MSOP Package Marking (Pb-Free)			
Device	Line 1 Marking	Device	Line 1 Marking
11AA010	11A01T	11LC010	11L01T
11AA020	11A02T	11LC020	11L02T
11AA040	11A04T	11LC040	11L04T
11AA080	11A08T	11LC080	11L08T
11AA160	11AAT	11LC160	11LAT
11AA161	11AA1T	11LC161	11LA1T

**Note:** T = Temperature Grade (I, E)

<p><b>Legend:</b> XX...X Part number or part number code  T Temperature (I, E)  Y Year code (last digit of calendar year)  YY Year code (last 2 digits of calendar year)  WW Week code (week of January 1 is week '01')  NNN Alphanumeric traceability code (2 characters for small packages)  ⓔ3 RoHS-compliant JEDEC® designator for Matte Tin (Sn)</p>
<p><b>Note:</b> Standard OTP marking consists of Microchip part number, year code, week code and traceability code.</p> <p><b>Note:</b> For very small packages with no room for the JEDEC® designator ⓔ3, the marking will only appear on the outer carton or reel label.</p> <p><b>Note:</b> In the event the full Microchip part number cannot be marked on one line, it will be carried over to the next line, thus limiting the number of available characters for customer-specific information.</p>

# 11AAXXX/11LCXXX

8-Lead 2x3 TDFN

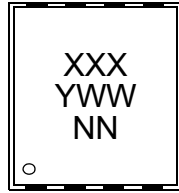

Example:

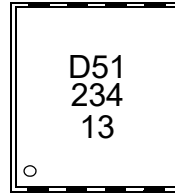

8-Lead 2x3 TDFN Package Marking (Pb-Free)

Device	I-Temp Marking	Device	I-Temp Marking	E-Temp Marking
11AA010	D11	11LC010	D14	D15
11AA020	D21	11LC020	D24	D25
11AA040	D31	11LC040	D34	D35
11AA080	D41	11LC080	D44	D45
11AA160	D51	11LC160	D54	D55
11AA161	D5D	11LC161	D5G	D5H

<b>Legend:</b>	XX...X	Part number or part number code
	T	Temperature (I, E)
	Y	Year code (last digit of calendar year)
	YY	Year code (last 2 digits of calendar year)
	WW	Week code (week of January 1 is week '01')
	NNN	Alphanumeric traceability code (2 characters for small packages)
	(e3)	RoHS-compliant JEDEC® designator for Matte Tin (Sn)

**Note:** Standard OTP marking consists of Microchip part number, year code, week code and traceability code.

**Note:** For very small packages with no room for the JEDEC® designator (e3), the marking will only appear on the outer carton or reel label.

**Note:** In the event the full Microchip part number cannot be marked on one line, it will be carried over to the next line, thus limiting the number of available characters for customer-specific information.

# 11AAXXX/11LCXXX

3-Lead SOT-23

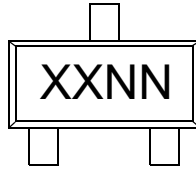

Example:

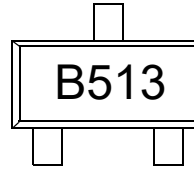

3-Lead SOT-23 Package Marking (Pb-Free)				
Device	I-Temp Marking	Device	I-Temp Marking	E-Temp Marking
11AA010	B1NN	11LC010	M1NN	N1NN
11AA020	B2NN	11LC020	M2NN	N2NN
11AA040	B3NN	11LC040	M3NN	N3NN
11AA080	B4NN	11LC080	M4NN	N4NN
11AA160	B5NN	11LC160	M5NN	N5NN
11AA161	B0NN	11LC161	M0NN	N0NN

**Legend:** XX...X Part number or part number code  
T Temperature (I, E)  
Y Year code (last digit of calendar year)  
YY Year code (last 2 digits of calendar year)  
WW Week code (week of January 1 is week '01')  
NNN Alphanumeric traceability code (2 characters for small packages)  
Ⓔ3 RoHS-compliant JEDEC® designator for Matte Tin (Sn)

**Note:** Standard OTP marking consists of Microchip part number, year code, week code and traceability code.

**Note:** For very small packages with no room for the JEDEC® designator Ⓔ3, the marking will only appear on the outer carton or reel label.

**Note:** In the event the full Microchip part number cannot be marked on one line, it will be carried over to the next line, thus limiting the number of available characters for customer-specific information.

# 11AAXX/11LCXX

3-Lead TO-92

Example:

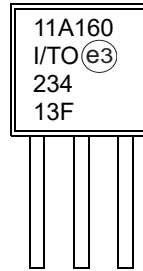
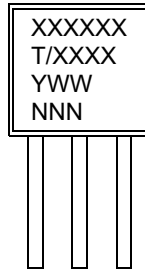

3-Lead TO-92 Package Marking (Pb-Free)			
Device	Line 1 Marking	Device	Line 1 Marking
11AA010	11A010	11LC010	11L010
11AA020	11A020	11LC020	11L020
11AA040	11A040	11LC040	11L040
11AA080	11A080	11LC080	11L080
11AA160	11A160	11LC160	11L160
11AA161	11A161	11LC161	11L161

**Note:** T = Temperature Grade (I, E)

**Legend:** XX...X Part number or part number code  
 T Temperature (I, E)  
 Y Year code (last digit of calendar year)  
 YY Year code (last 2 digits of calendar year)  
 WW Week code (week of January 1 is week '01')  
 NNN Alphanumeric traceability code (2 characters for small packages)  
 (e3) RoHS-compliant JEDEC® designator for Matte Tin (Sn)

**Note:** Standard OTP marking consists of Microchip part number, year code, week code and traceability code.

**Note:** For very small packages with no room for the JEDEC® designator (e3), the marking will only appear on the outer carton or reel label.

**Note:** In the event the full Microchip part number cannot be marked on one line, it will be carried over to the next line, thus limiting the number of available characters for customer-specific information.

4-Lead Chip Scale

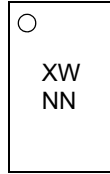

Example:

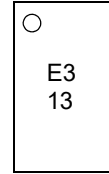

4-Lead Chip Scale Package Marking (Pb-Free)	
Device	Line 1 Marking
11AA010	AW
11AA020	BW
11AA040	CW
11AA080	DW
11AA160	EW
11AA161	HW

**Legend:** XX...X Part number or part number code  
 T Temperature (I, E)  
 Y Year code (last digit of calendar year)  
 YY Year code (last 2 digits of calendar year)  
 WW Week code (week of January 1 is week '01')  
 NNN Alphanumeric traceability code (2 characters for small packages)  
 ⓔ3 RoHS-compliant JEDEC® designator for Matte Tin (Sn)

**Note:** Standard OTP marking consists of Microchip part number, year code, week code and traceability code.

**Note:** For very small packages with no room for the JEDEC® designator ⓔ3, the marking will only appear on the outer carton or reel label.

**Note:** In the event the full Microchip part number cannot be marked on one line, it will be carried over to the next line, thus limiting the number of available characters for customer-specific information.

# 11AAXX/11LCXX

## 8-Lead Plastic Dual In-Line (P) - 300 mil Body [PDIP]

**Note:** For the most current package drawings, please see the Microchip Packaging Specification located at <http://www.microchip.com/packageing>

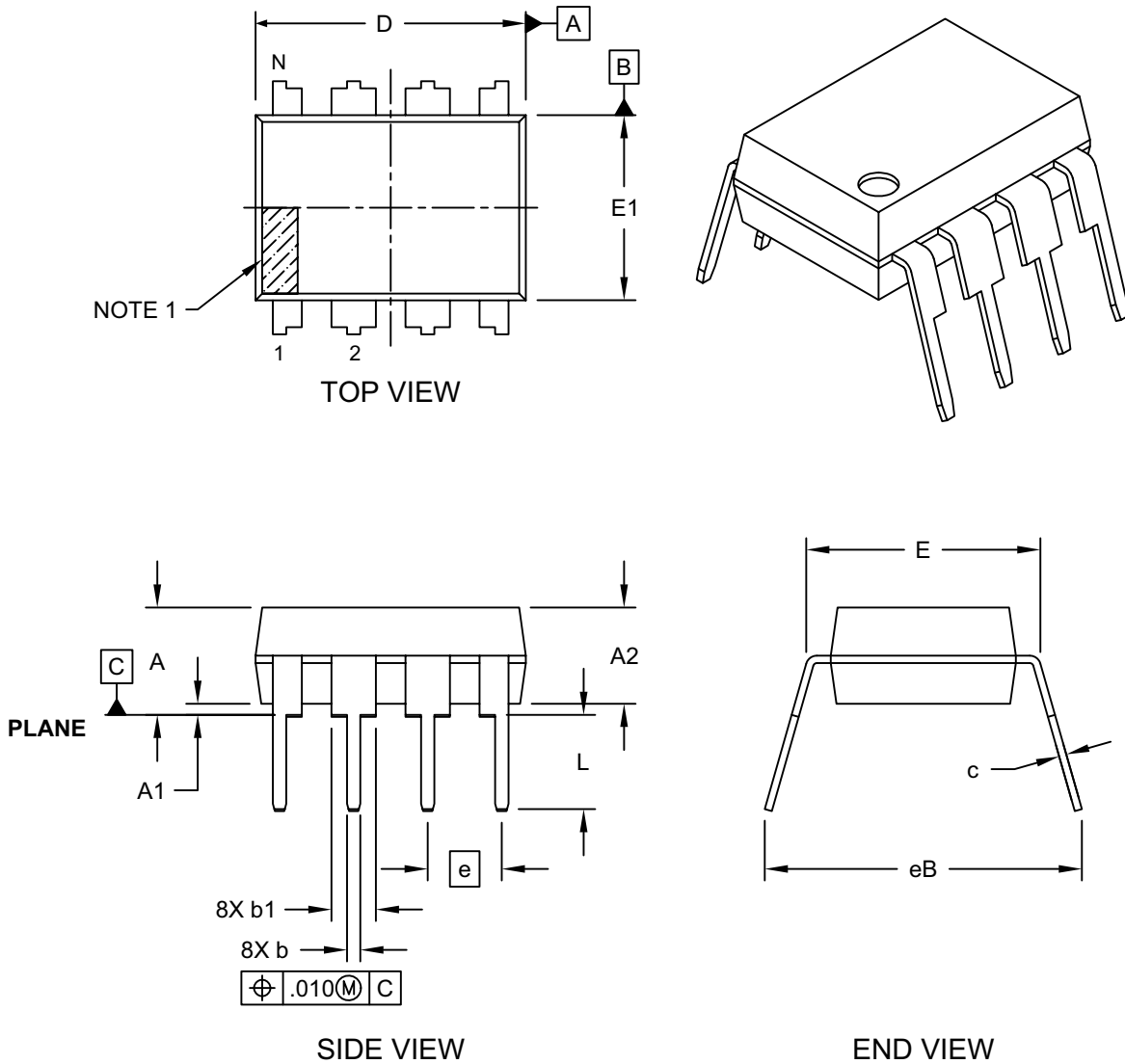

Microchip Technology Drawing No. C04-018-P Rev F Sheet 1 of 2

## 8-Lead Plastic Dual In-Line (P) - 300 mil Body [PDIP]

**Note:** For the most current package drawings, please see the Microchip Packaging Specification located at <http://www.microchip.com/packaging>

### ALTERNATE LEAD DESIGN (NOTE 5)

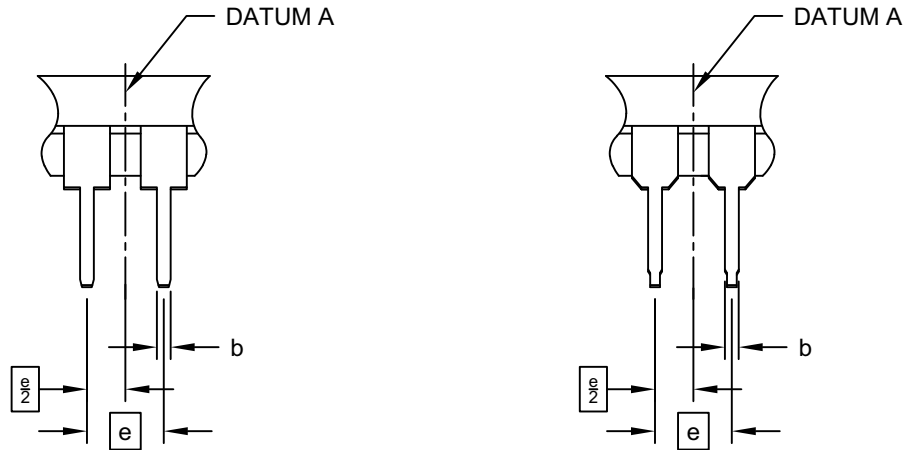

Dimension Limits	Units	INCHES		
		MIN	NOM	MAX
Number of Pins	N	8		
Pitch	e	.100 BSC		
Top to Seating Plane	A	-	-	.210
Molded Package Thickness	A2	.115	.130	.195
Base to Seating Plane	A1	.015	-	-
Shoulder to Shoulder Width	E	.290	.310	.325
Molded Package Width	E1	.240	.250	.280
Overall Length	D	.348	.365	.400
Tip to Seating Plane	L	.115	.130	.150
Lead Thickness	c	.008	.010	.015
Upper Lead Width	b1	.040	.060	.070
Lower Lead Width	b	.014	.018	.022
Overall Row Spacing	§	eB	-	.430

**Notes:**

1. Pin 1 visual index feature may vary, but must be located within the hatched area.
2. § Significant Characteristic
3. Dimensions D and E1 do not include mold flash or protrusions. Mold flash or protrusions shall not exceed .010" per side.
4. Dimensioning and tolerancing per ASME Y14.5M
  - BSC: Basic Dimension. Theoretically exact value shown without tolerances.
5. Lead design above seating plane may vary, based on assembly vendor.

Microchip Technology Drawing No. C04-018-P Rev F Sheet 2 of 2

# 11AAXX/11LCXX

## 8-Lead Plastic Small Outline (SN) - Narrow, 3.90 mm (.150 In.) Body [SOIC]

**Note:** For the most current package drawings, please see the Microchip Packaging Specification located at <http://www.microchip.com/packaging>

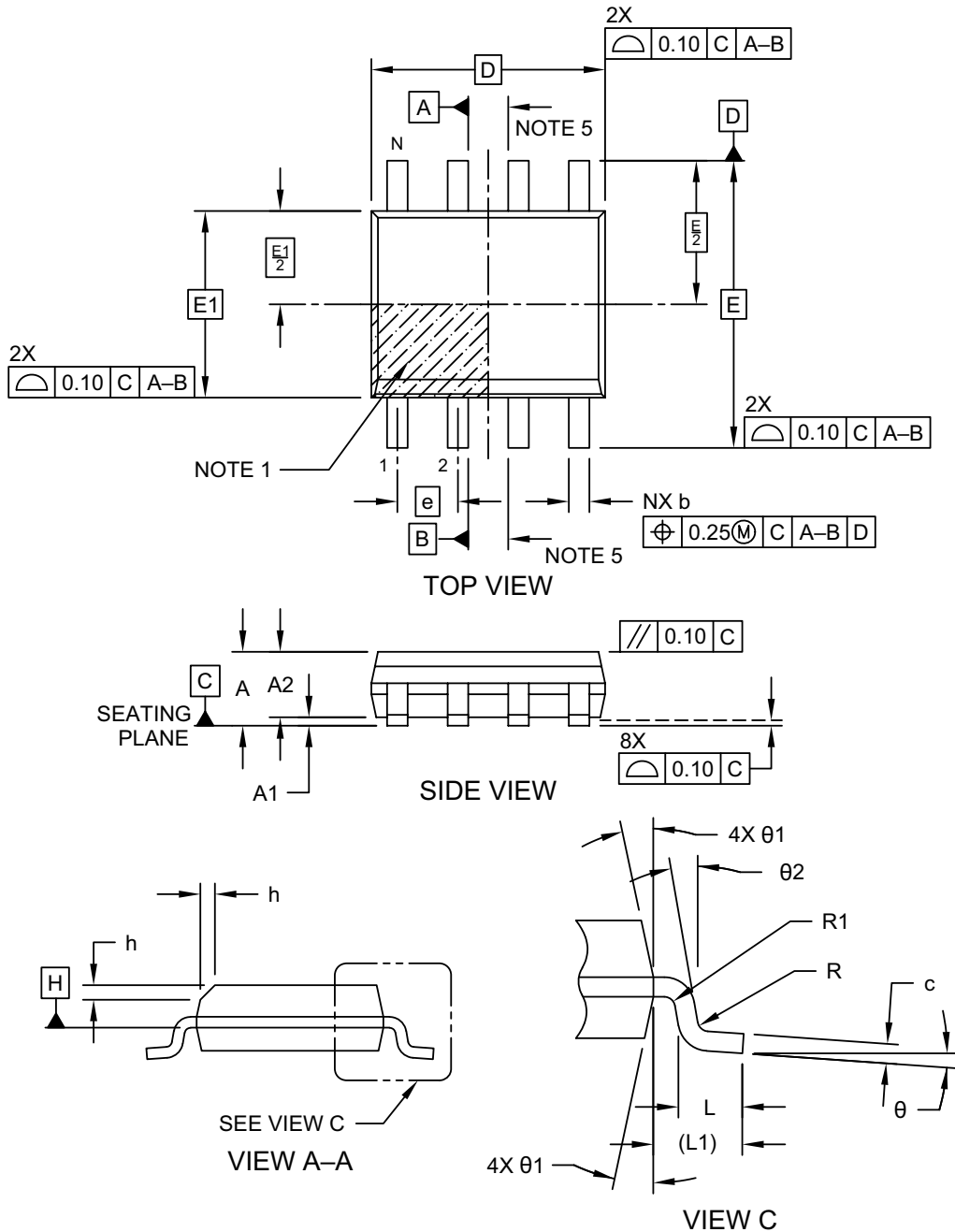

Microchip Technology Drawing No. C04-057-SN Rev K Sheet 1 of 2

## 8-Lead Plastic Small Outline (SN) - Narrow, 3.90 mm (.150 In.) Body [SOIC]

**Note:** For the most current package drawings, please see the Microchip Packaging Specification located at <http://www.microchip.com/packaging>

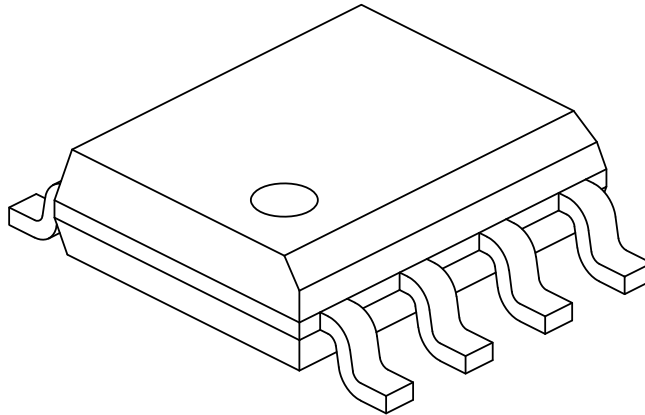

Dimension	Units	MILLIMETERS		
		MIN	NOM	MAX
Number of Pins	N	8		
Pitch	e	1.27 BSC		
Overall Height	A	–	–	1.75
Molded Package Thickness	A2	1.25	–	–
Standoff §	A1	0.10	–	0.25
Overall Width	E	6.00 BSC		
Molded Package Width	E1	3.90 BSC		
Overall Length	D	4.90 BSC		
Chamfer (Optional)	h	0.25	–	0.50
Foot Length	L	0.40	–	1.27
Footprint	L1	1.04 REF		
Lead Thickness	c	0.17	–	0.25
Lead Width	b	0.31	–	0.51
Lead Bend Radius	R	0.07	–	–
Lead Bend Radius	R1	0.07	–	–
Foot Angle	θ	0°	–	8°
Mold Draft Angle	θ1	5°	–	15°
Lead Angle	θ2	0°	–	–

**Notes:**

- Pin 1 visual index feature may vary, but must be located within the hatched area.
- § Significant Characteristic
- Dimensions D and E1 do not include mold flash or protrusions. Mold flash or protrusions shall not exceed 0.15mm per side.
- Dimensioning and tolerancing per ASME Y14.5M  
BSC: Basic Dimension. Theoretically exact value shown without tolerances.  
REF: Reference Dimension, usually without tolerance, for information purposes only.
- Datums A & B to be determined at Datum H.

Microchip Technology Drawing No. C04-057-SN Rev K Sheet 2 of 2

# 11AAXXX/11LCXXX

## 8-Lead Plastic Small Outline (SN) - Narrow, 3.90 mm (.150 In.) Body [SOIC]

**Note:** For the most current package drawings, please see the Microchip Packaging Specification located at <http://www.microchip.com/packaging>

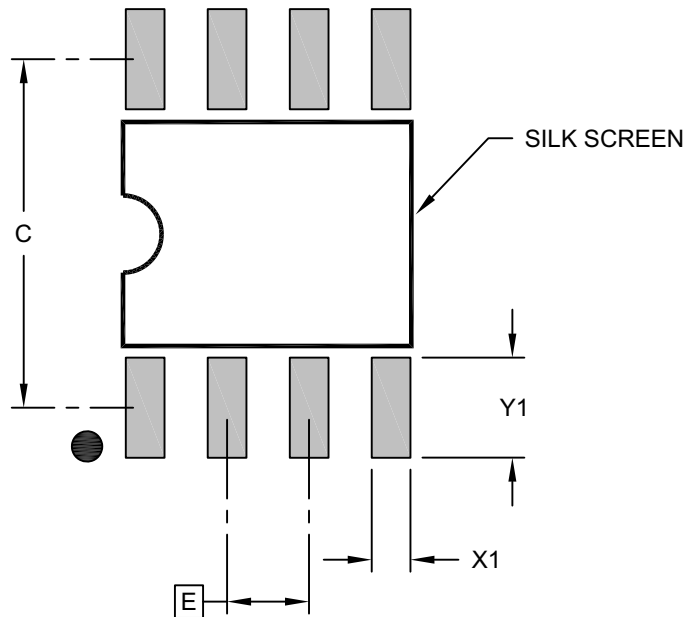

RECOMMENDED LAND PATTERN

Dimension Limits	Units	MILLIMETERS		
		MIN	NOM	MAX
Contact Pitch	E	1.27 BSC		
Contact Pad Spacing	C		5.40	
Contact Pad Width (X8)	X1			0.60
Contact Pad Length (X8)	Y1			1.55

**Notes:**

1. Dimensioning and tolerancing per ASME Y14.5M

BSC: Basic Dimension. Theoretically exact value shown without tolerances.

Microchip Technology Drawing C04-2057-SN Rev K

## 8-Lead Plastic Micro Small Outline Package (MS) - 3x3 mm Body [MSOP]

**Note:** For the most current package drawings, please see the Microchip Packaging Specification located at <http://www.microchip.com/packaging>

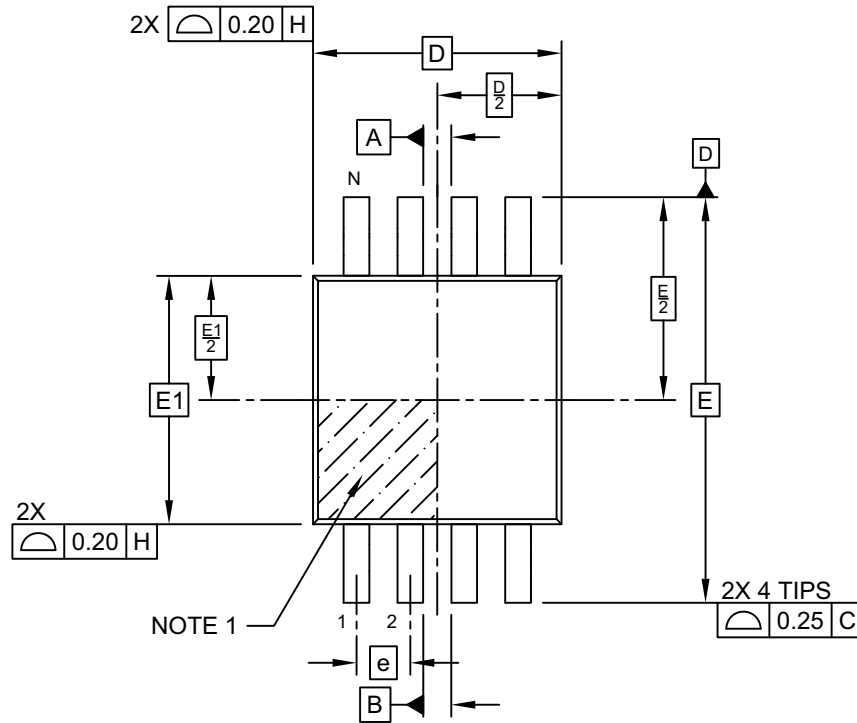

TOP VIEW

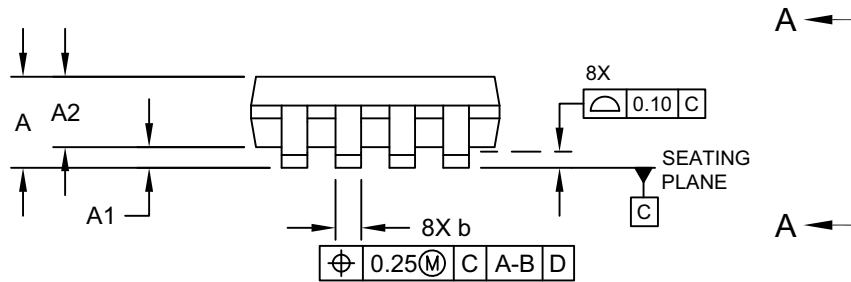

SIDE VIEW

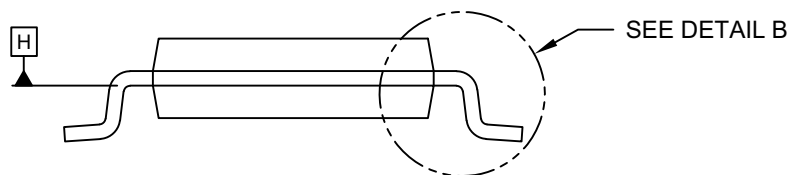

VIEW A-A

Microchip Technology Drawing C04-111-MS Rev F Sheet 1 of 2

# 11AXXX/11LCXXX

## 8-Lead Plastic Micro Small Outline Package (MS) - 3x3 mm Body [MSOP]

**Note:** For the most current package drawings, please see the Microchip Packaging Specification located at <http://www.microchip.com/packaging>

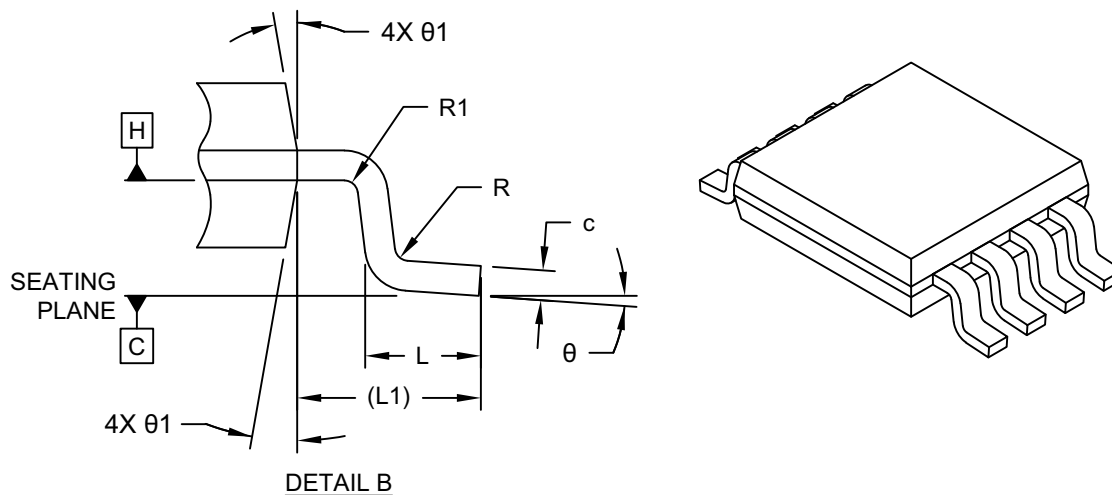

Dimension Limits	Units	MILLIMETERS		
		MIN	NOM	MAX
Number of Terminals	N	8		
Pitch	e	0.65 BSC		
Overall Height	A	–	–	1.10
Standoff	A1	0.00	–	0.15
Molded Package Thickness	A2	0.75	0.85	0.95
Overall Length	D	3.00 BSC		
Overall Width	E	4.90 BSC		
Molded Package Width	E1	3.00 BSC		
Terminal Width	b	0.22	–	0.40
Terminal Thickness	c	0.08	–	0.23
Terminal Length	L	0.40	0.60	0.80
Footprint	L1	0.95 REF		
Lead Bend Radius	R	0.07	–	–
Lead Bend Radius	R1	0.07	–	–
Foot Angle	θ	0°	–	8°
Mold Draft Angle	θ1	5°	–	15°

**Notes:**

- Pin 1 visual index feature may vary, but must be located within the hatched area.
- Dimensions D and E1 do not include mold flash or protrusions. Mold flash or protrusions shall not exceed 0.15mm per side.
- Dimensioning and tolerancing per ASME Y14.5M  
 BSC: Basic Dimension. Theoretically exact value shown without tolerances.  
 REF: Reference Dimension, usually without tolerance, for information purposes only.

Microchip Technology Drawing C04-111-MS Rev F Sheet 2 of 2

## 8-Lead Plastic Micro Small Outline Package (MS) - 3x3 mm Body [MSOP]

**Note:** For the most current package drawings, please see the Microchip Packaging Specification located at <http://www.microchip.com/packaging>

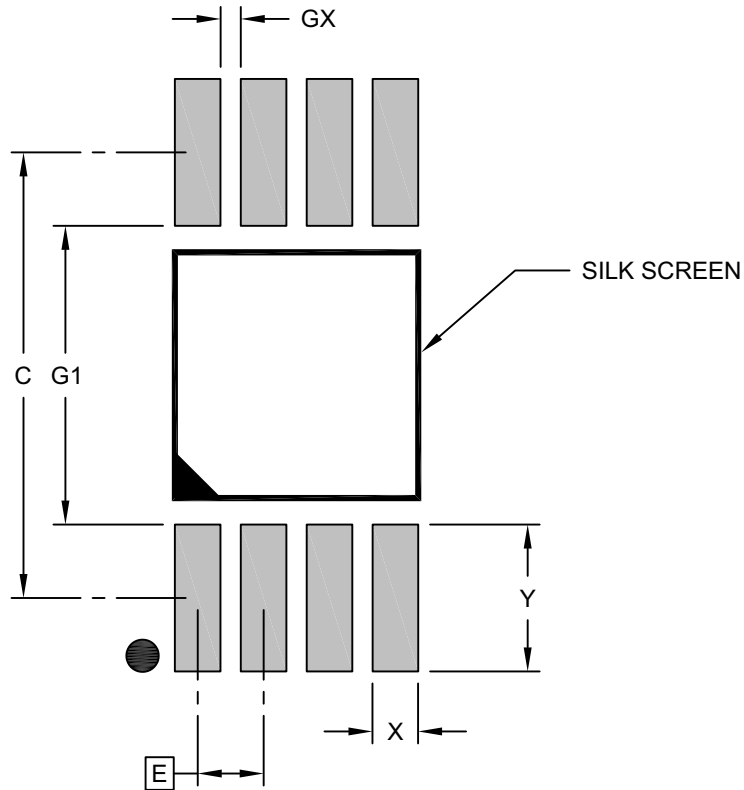

### RECOMMENDED LAND PATTERN

Dimension Limits	Units	MILLIMETERS		
		MIN	NOM	MAX
Contact Pitch	E	0.65 BSC		
Contact Pad Spacing	C		4.40	
Contact Pad Width (X8)	X			0.45
Contact Pad Length (X8)	Y			1.45
Contact Pad to Contact Pad (X4)	G1	2.95		
Contact Pad to Contact Pad (X6)	GX	0.20		

**Notes:**

1. Dimensioning and tolerancing per ASME Y14.5M  
BSC: Basic Dimension. Theoretically exact value shown without tolerances.

Microchip Technology Drawing C04-2111-MS Rev F

# 11AAXX/11LCXX

## 8-Lead Plastic Dual Flat, No Lead Package (MN) – 2x3x0.8 mm Body [TDFN] With 1.4x1.3 mm Exposed Pad (JEDEC Package type WDFN)

**Note:** For the most current package drawings, please see the Microchip Packaging Specification located at <http://www.microchip.com/packaging>

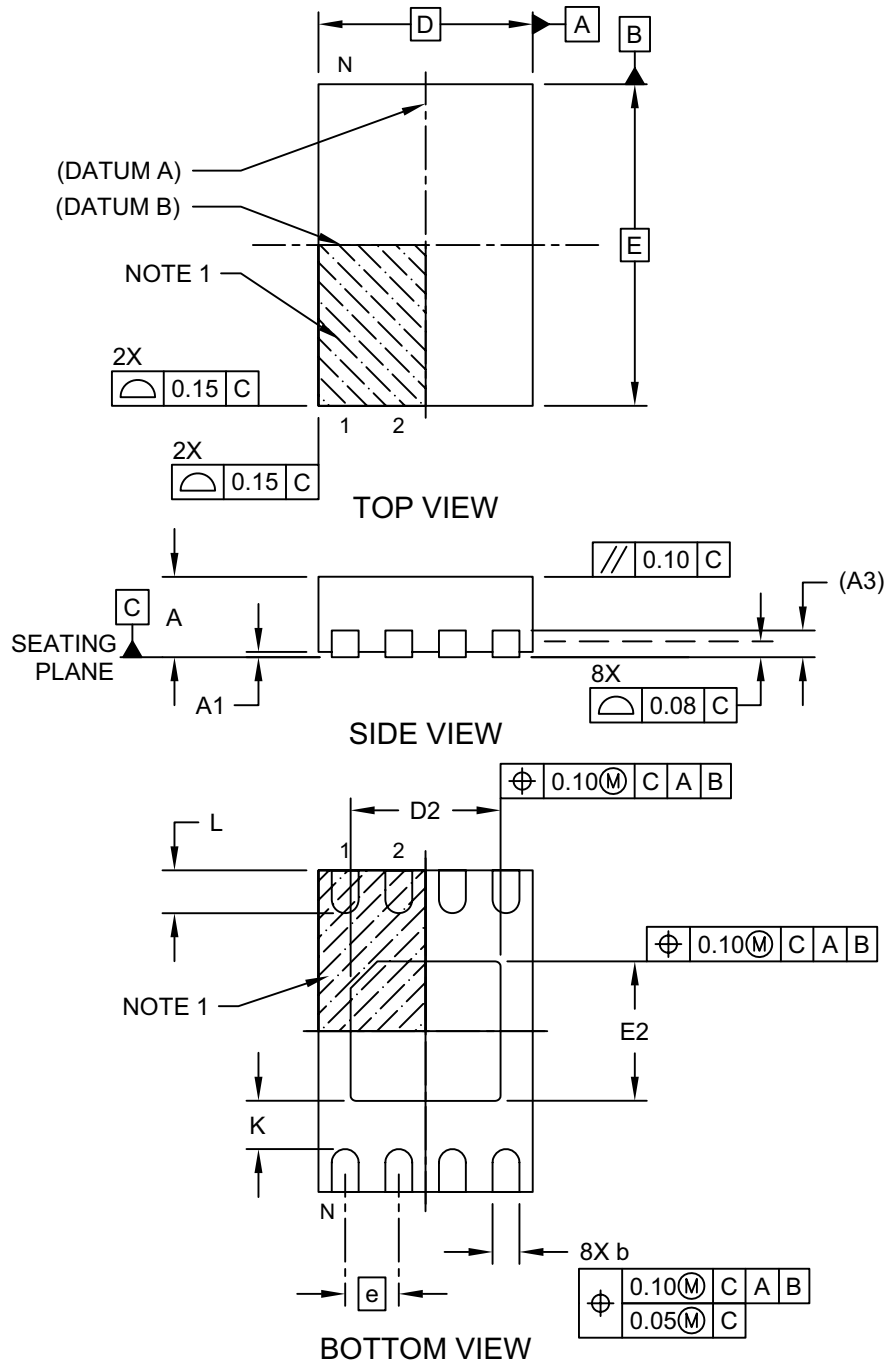

Microchip Technology Drawing No. C04-129-MN Rev E Sheet 1 of 2

## 8-Lead Plastic Dual Flat, No Lead Package (MN) – 2x3x0.8 mm Body [TDFN] With 1.4x1.3 mm Exposed Pad (JEDEC Package type WDFN)

**Note:** For the most current package drawings, please see the Microchip Packaging Specification located at <http://www.microchip.com/packaging>

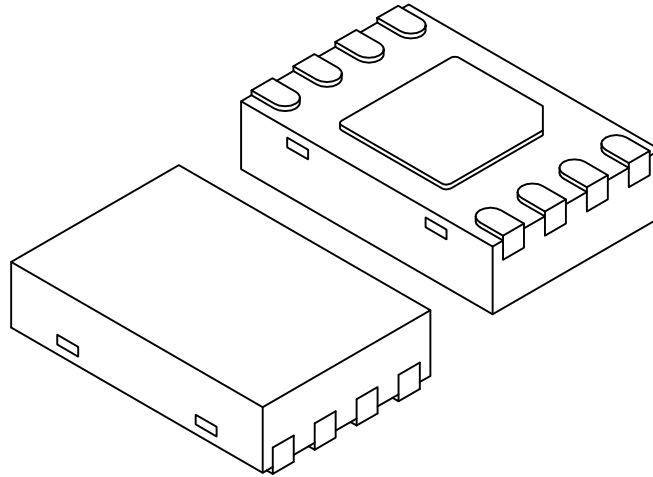

		Units	MILLIMETERS		
Dimension Limits			MIN	NOM	MAX
Number of Pins	N		8		
Pitch	e		0.50 BSC		
Overall Height	A		0.70	0.75	0.80
Standoff	A1		0.00	0.02	0.05
Contact Thickness	A3		0.20 REF		
Overall Length	D		2.00 BSC		
Overall Width	E		3.00 BSC		
Exposed Pad Length	D2		1.35	1.40	1.45
Exposed Pad Width	E2		1.25	1.30	1.35
Contact Width	b		0.20	0.25	0.30
Contact Length	L		0.25	0.30	0.45
Contact-to-Exposed Pad	K		0.20	-	-

### Notes:

1. Pin 1 visual index feature may vary, but must be located within the hatched area.
2. Package may have one or more exposed tie bars at ends.
3. Package is saw singulated
4. Dimensioning and tolerancing per ASME Y14.5M

BSC: Basic Dimension. Theoretically exact value shown without tolerances.

REF: Reference Dimension, usually without tolerance, for information purposes only.

Microchip Technology Drawing No. C04-129-MN Rev E Sheet 2 of 2

# 11AAXX/11LCXX

## 8-Lead Plastic Dual Flat, No Lead Package (MN) – 2x3x0.8 mm Body [TDFN] With 1.4x1.3 mm Exposed Pad (JEDEC Package type WDFN)

**Note:** For the most current package drawings, please see the Microchip Packaging Specification located at <http://www.microchip.com/packaging>

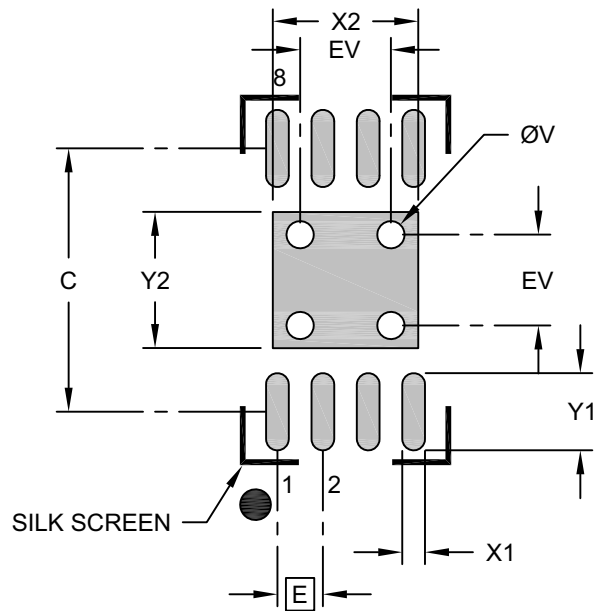

RECOMMENDED LAND PATTERN

Dimension Limits	Units	MILLIMETERS		
		MIN	NOM	MAX
Contact Pitch	E	0.50 BSC		
Optional Center Pad Width	X2			1.60
Optional Center Pad Length	Y2			1.50
Contact Pad Spacing	C		2.90	
Contact Pad Width (X8)	X1			0.25
Contact Pad Length (X8)	Y1			0.85
Thermal Via Diameter	V		0.30	
Thermal Via Pitch	EV		1.00	

**Notes:**

1. Dimensioning and tolerancing per ASME Y14.5M  
BSC: Basic Dimension. Theoretically exact value shown without tolerances.
2. For best soldering results, thermal vias, if used, should be filled or tented to avoid solder loss during reflow process

Microchip Technology Drawing No. C04-129-MN Rev. B

## 3-Lead Plastic Transistor Outline (TO) [TO-92]

**Note:** For the most current package drawings, please see the Microchip Packaging Specification located at <http://www.microchip.com/packaging>

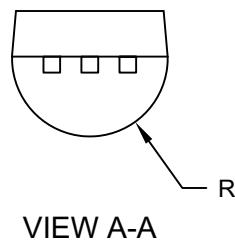
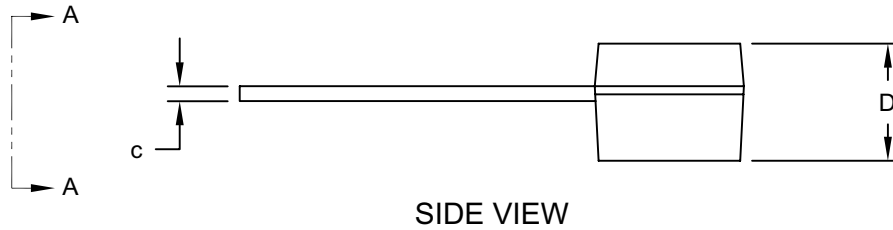
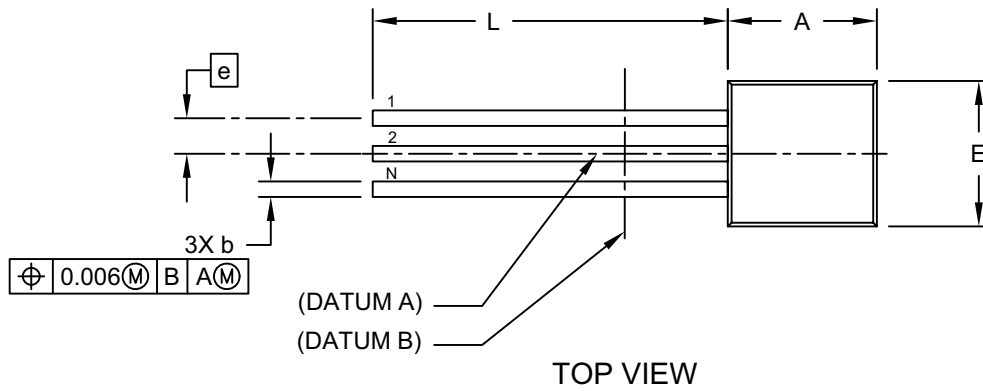

# 11AAXXX/11LCXXX

## 3-Lead Plastic Transistor Outline (TO) [TO-92]

**Note:** For the most current package drawings, please see the Microchip Packaging Specification located at <http://www.microchip.com/packaging>

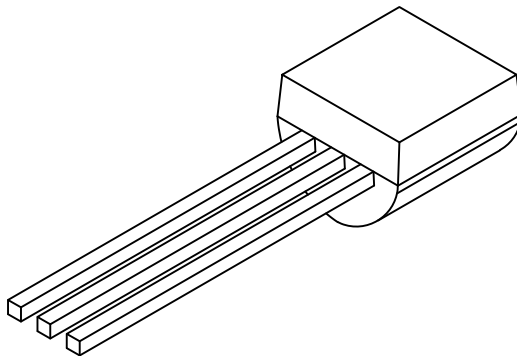

Dimension Limits	Units	INCHES		
		MIN	NOM	MAX
Number of Pins	N	3		
Pitch	e	.050 BSC		
Bottom to Package Flat	D	.125	-	.165
Overall Width	E	.175	-	.205
Overall Length	A	.170	-	.210
Molded Package Radius	R	.080	-	.105
Tip to Seating Plane	L	.500	-	-
Lead Thickness	c	.014	-	.021
Lead Width	b	.014	-	.022

### Notes:

1. Dimensions D and E do not include mold flash or protrusions. Mold flash or protrusions shall not exceed .005" per side.
2. Dimensioning and tolerancing per ASME Y14.5M  
BSC: Basic Dimension. Theoretically exact value shown without tolerances.

Microchip Technology Drawing C04-101-TO Rev D Sheet 2 of 2

## 3-Lead Plastic Small Outline Transistor (TT) [SOT-23]

**Note:** For the most current package drawings, please see the Microchip Packaging Specification located at <http://www.microchip.com/packaging>

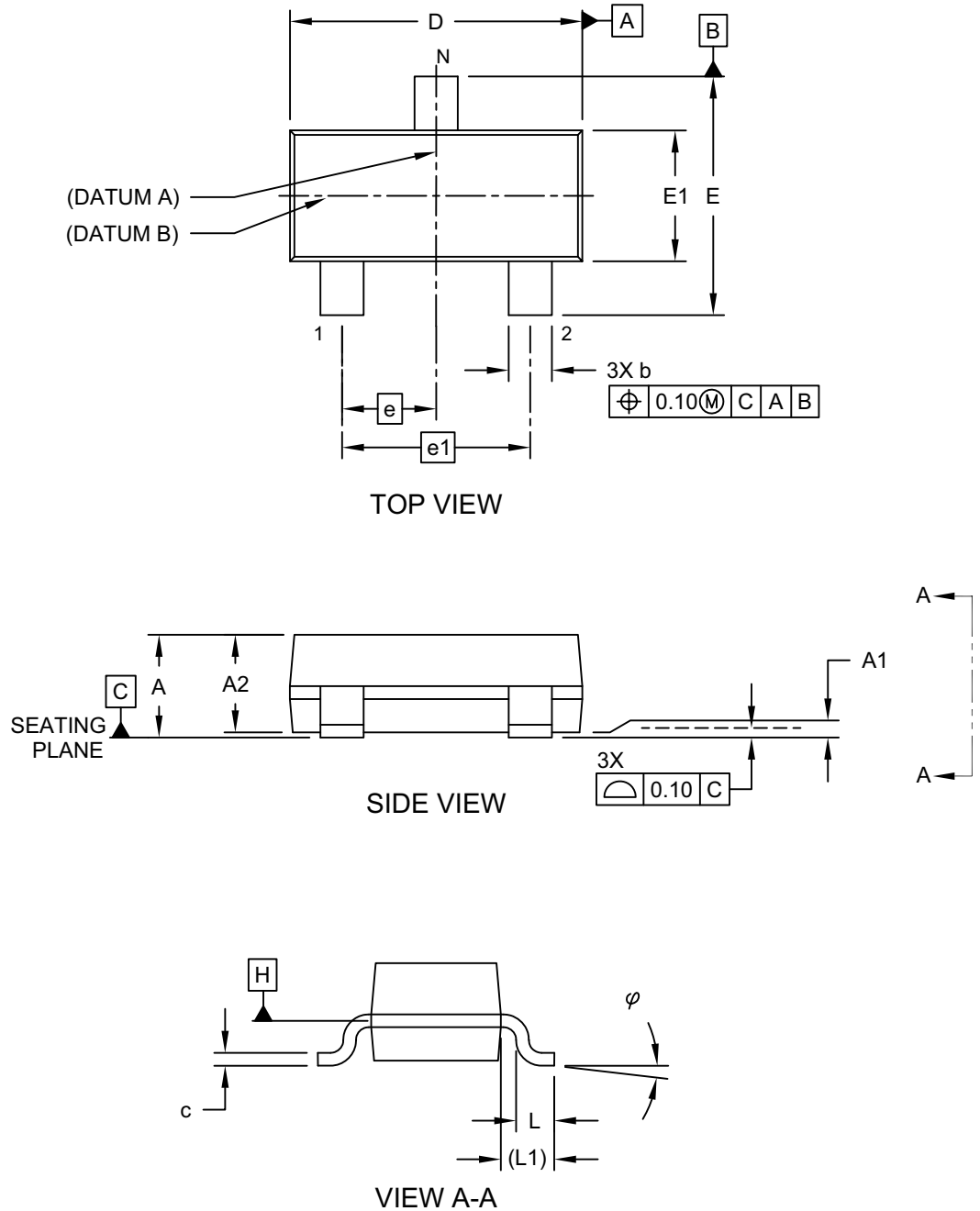

Microchip Technology Drawing C04-104 (TT) Rev C Sheet 1 of 2

# 11AAXXX/11LCXXX

## 3-Lead Plastic Small Outline Transistor (TT) [SOT-23]

**Note:** For the most current package drawings, please see the Microchip Packaging Specification located at <http://www.microchip.com/packaging>

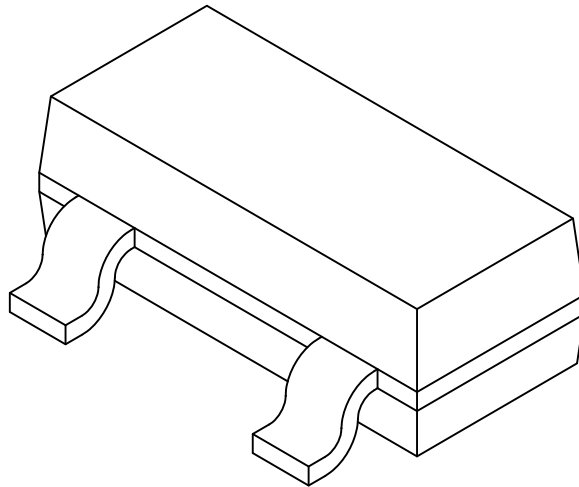

Dimension Limits	Units	MILLIMETERS		
		MIN	NOM	MAX
Number of Pins	N	3		
Lead Pitch	e	0.95 BSC		
Outside Lead Pitch	e1	1.90 BSC		
Overall Height	A	0.89	-	1.12
Molded Package Thickness	A2	0.79	0.95	1.02
Standoff	A1	0.01	-	0.10
Overall Width	E	2.10	-	2.64
Molded Package Width	E1	1.16	1.30	1.40
Overall Length	D	2.67	2.90	3.05
Foot Length	L	0.13	0.50	0.60
Footprint	(L1)	0.42 REF		
Foot Angle	$\varphi$	0°	-	10°
Lead Thickness	c	0.08	-	0.20
Lead Width	b	0.30	-	0.54

**Notes:**

- Dimensions D and E1 do not include mold flash or protrusions. Mold flash or protrusions shall not exceed 0.127mm per side.
- Dimensioning and tolerancing per ASME Y14.5M  
BSC: Basic Dimension. Theoretically exact value shown without tolerances.  
REF: Reference Dimension, usually without tolerance, for information purposes only.

Microchip Technology Drawing C04-104 (TT) Rev C Sheet 2 of 2

## 3-Lead Plastic Small Outline Transistor (TT) [SOT-23]

**Note:** For the most current package drawings, please see the Microchip Packaging Specification located at <http://www.microchip.com/packaging>

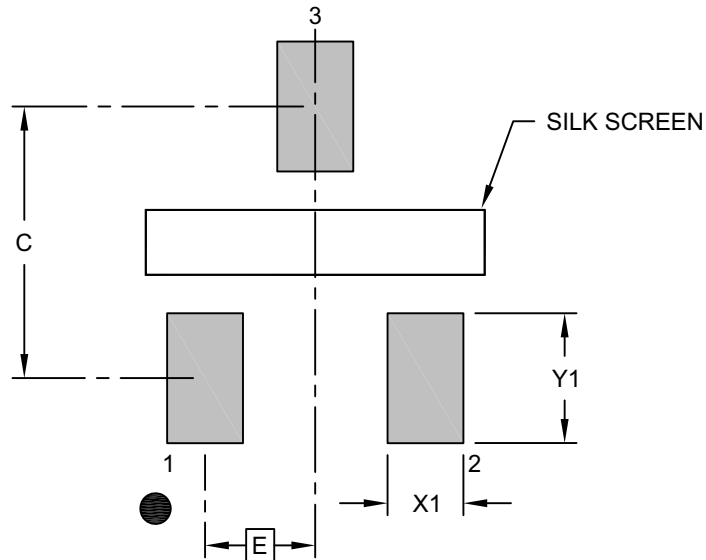

### RECOMMENDED LAND PATTERN

Dimension Limits	Units	MILLIMETERS		
		MIN	NOM	MAX
Contact Pitch	E	0.95 BSC		
Contact Pad Spacing	C		2.30	
Contact Pad Width (X3)	X1			0.65
Contact Pad Length (X3)	Y1			1.10

**Notes:**

- Dimensioning and tolerancing per ASME Y14.5M  
BSC: Basic Dimension. Theoretically exact value shown without tolerances.
- For best soldering results, thermal vias, if used, should be filled or tented to avoid solder loss during reflow process

Microchip Technology Drawing C04-2104 (TT) Rev B

# 11AXXX/11LCXXX

## 4-Lead Chip Scale Package (CS) - [CSP]

**Note:** For the most current package drawings, please see the Microchip Packaging Specification located at <http://www.microchip.com/packaging>

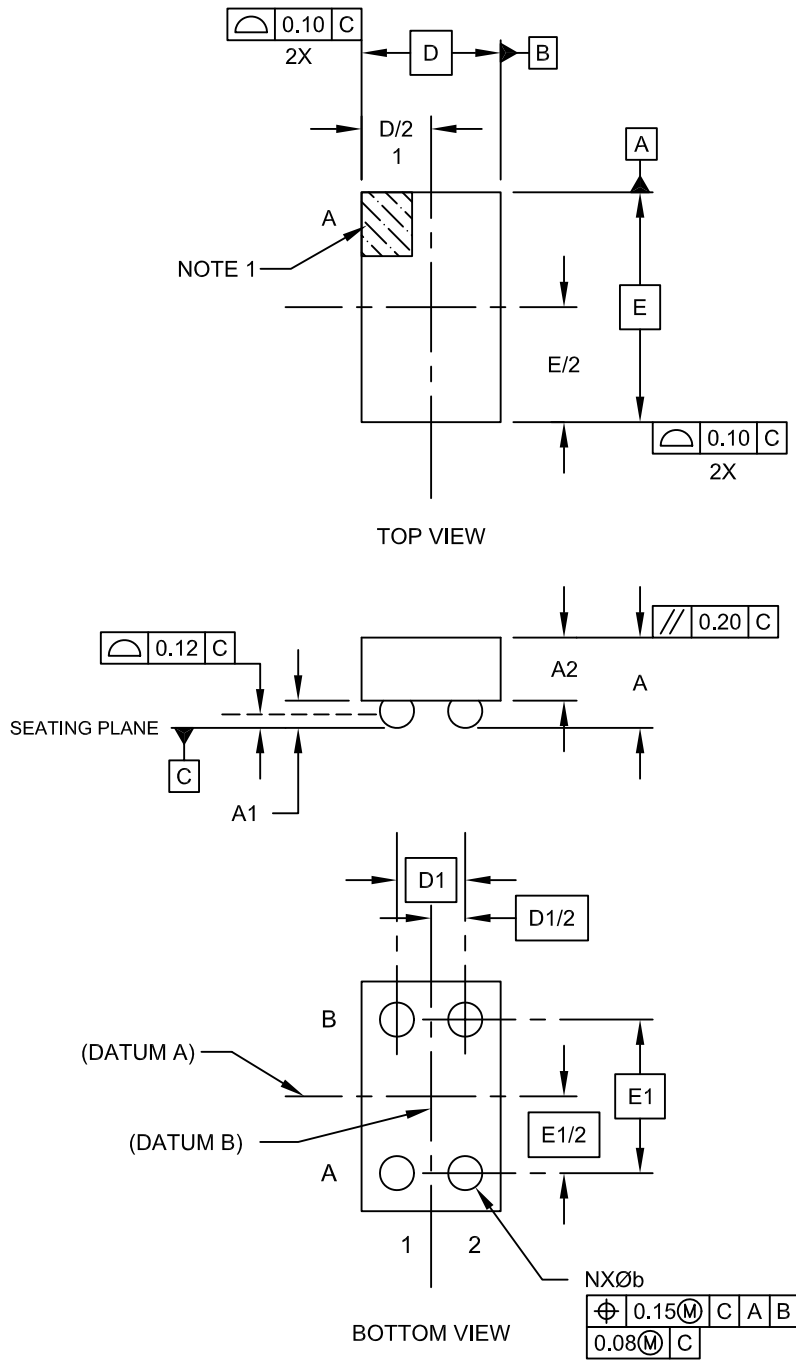

Microchip Technology Drawing C04-6008A Sheet 1 of 2

## 4-Lead Chip Scale Package (CS) - [CSP]

**Note:** For the most current package drawings, please see the Microchip Packaging Specification located at <http://www.microchip.com/packaging>

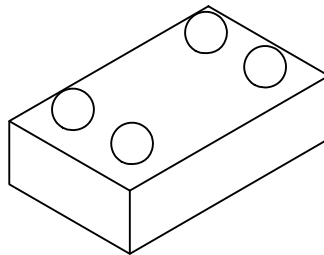

Dimension Limits	Units	MILLIMETERS		
		MIN	NOM	MAX
Number of Contacts	N	4		
Adjacent Column X-Pitch	D1	0.400 BSC		
Adjacent Row Y-Pitch	E1	0.900 BSC		
Overall Height	A	0.47	0.51	0.55
Die Height	A2	0.33	0.35	0.37
Bump Height	A1	0.14	0.16	0.18
Overall Width	D	NOTE 4		
Overall Length	E	NOTE 4		
Ball Diameter	b	0.18	0.20	0.22

**Notes:**

1. Orientation reference feature may vary, but must be located within the hatched area.
2. Package is saw singulated.
3. Dimensioning and tolerancing per ASME Y14.5M.  
BSC: Basic Dimension. Theoretically exact value shown without tolerances.  
REF: Reference Dimension, usually without tolerance, for information purposes only.
4. Package size varies with specific devices. Please see the specific Product Data Sheet.

Microchip Technology Drawing C04-6008A Sheet 2 of 2

# 11AAXX/11LCXX

## 4-Lead Chip Scale Package (CS) - [CSP]

**Note:** For the most current package drawings, please see the Microchip Packaging Specification located at <http://www.microchip.com/packaging>

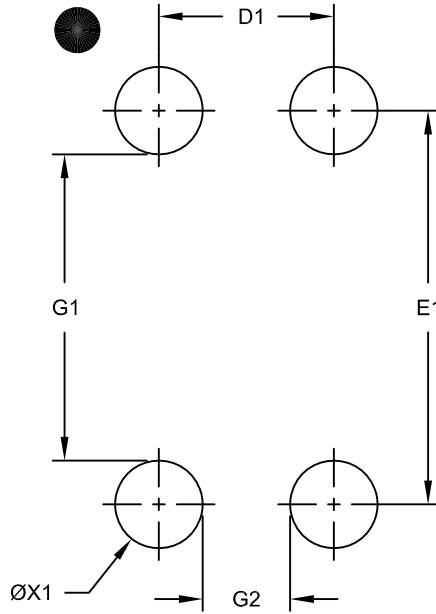

RECOMMENDED LAND PATTERN

Dimension Limits	Units	MILLIMETERS		
		MIN	NOM	MAX
Number of Contacts	N	4		
Contact Pad Spacing	D1		0.40	
Contact Pad Spacing	E1		0.90	
Contact Pad Diameter (X4)	ØX1		0.20	
Distance Between Pads	G1		0.70	
Distance Between Pads	G2		0.20	

**Notes:**

1. Dimensioning and tolerancing per ASME Y14.5M

BSC: Basic Dimension. Theoretically exact value shown without tolerances.

Microchip Technology Drawing No. C04-8008A

## APPENDIX A: REVISION HISTORY

### Revision K (03/23)

Updated formatting to current template; Replaced terminology “Master” and “Slave” with “Host” and “Client” respectively; Added Automotive PIS.

### Revision J (04/11)

Added new Patent No.; Revised Table 1-2, Param Nos 3 and 4.

### Revision H (03/10)

Added 4-lead Chip Scale package.

### Revision G (12/09)

Added 11AA161/11LC161 device.

### Revision F (10/09)

Added 3-lead TO-92 Package.

### Revision E (09/08)

Updated UNI/O trademark; Revised Table 1-2, parameters 3 and 5; Updated package drawings.

### Revision D (04/08)

Revised document status to Preliminary; General updates.

### Revision C (03/08)

Removed patent pending notice; Revised Tables 1-1 and 1-2; Section 3.3 (bullet 3) and 3.7 (bullet 2); Product ID System.

### Revision B (01/08)

Revised SOT-23 Package Type; Revised DFN package to TDFN; Section 3.3 (added new bullet item); Section 4.5 note; Table 7-1.

### Revision A (10/07)

Original release of this document.

# 11AAXXX/11LCXXX

---

---

NOTES:

## THE MICROCHIP WEBSITE

Microchip provides online support via our website at [www.microchip.com](http://www.microchip.com). This website is used as a means to make files and information easily available to customers. Accessible by using your favorite Internet browser, the website contains the following information:

- **Product Support** – Data sheets and errata, application notes and sample programs, design resources, user's guides and hardware support documents, latest software releases and archived software
- **General Technical Support** – Frequently Asked Questions (FAQ), technical support requests, online discussion groups, Microchip consultant program member listing
- **Business of Microchip** – Product selector and ordering guides, latest Microchip press releases, listing of seminars and events, listings of Microchip sales offices, distributors and factory representatives

## CUSTOMER CHANGE NOTIFICATION SERVICE

Microchip's customer notification service helps keep customers current on Microchip products. Subscribers will receive e-mail notification whenever there are changes, updates, revisions or errata related to a specified product family or development tool of interest.

To register, access the Microchip website at [www.microchip.com](http://www.microchip.com). Under "Support", click on "Customer Change Notification" and follow the registration instructions.

## CUSTOMER SUPPORT

Users of Microchip products can receive assistance through several channels:

- Distributor or Representative
- Local Sales Office
- Field Application Engineer (FAE)
- Technical Support

Customers should contact their distributor, representative or Field Application Engineer (FAE) for support. Local sales offices are also available to help customers. A listing of sales offices and locations is included in the back of this document.

**Technical support is available through the website at: <http://microchip.com/support>**

# 11AAXXX/11LCXXX

---

---

NOTES:

## PRODUCT IDENTIFICATION SYSTEM (NON-AUTOMOTIVE)

To order or obtain information, e.g., on pricing or delivery, refer to the factory or the listed sales office.

PART NO.	X	X <sup>(1)</sup>	—	X	/XXX
Device	Device Address	Tape & Reel	—	Temperature Range	Package
<p><b>Device:</b></p> <p>11AA01 = 1-Kbit, 1.8V UNI/O Serial EEPROM            11LC01 = 1-Kbit, 2.5V UNI/O Serial EEPROM            11AA02 = 2-Kbit, 1.8V UNI/O Serial EEPROM            11LC02 = 2-Kbit, 2.5V UNI/O Serial EEPROM            11AA04 = 4-Kbit, 1.8V UNI/O Serial EEPROM            11LC04 = 4-Kbit, 2.5V UNI/O Serial EEPROM            11AA08 = 8-Kbit, 1.8V UNI/O Serial EEPROM            11LC08 = 8-Kbit, 2.5V UNI/O Serial EEPROM            11AA16 = 16-Kbit, 1.8V UNI/O Serial EEPROM            11LC16 = 16-Kbit, 2.5V UNI/O Serial EEPROM</p> <p><b>Device Address:</b></p> <p>0 = Standard Address – 0xA0            1 = Alternate Address – 0xA1 (11XX161 only)</p> <p><b>Tape &amp; Reel:</b></p> <p>T = Tape and Reel<sup>(1)</sup>            Blank = Tube</p> <p><b>Temperature Range:</b></p> <p>I = -40°C to +85°C (Industrial)            E = -40°C to +125°C (Extended)</p> <p><b>Package:</b></p> <p>P = 8-lead Plastic DIP (300 mil body)            SN = 8-lead Plastic SOIC (3.90 mm body)            MS = 8-lead Plastic Micro Small Outline (MSOP)            MNY<sup>(2)</sup> = 8-lead 2x3 mm TDFN            TO = 3-lead Plastic TO-92            TT = 3-lead SOT-23 (Tape and Reel only)            CS16K<sup>(3)</sup> = Chip Scale (CS), 4-lead (I-temp, "AA", Tape and Reel only)</p>					
<p><b>Examples:</b></p> <p>a) 11AA010-I/P: 1-Kbit, 1.8V Serial EEPROM, Industrial temp., Standard address, PDIP package            b) 11LC160T-E/TT: 16-Kbit, 2.5V Serial EEPROM, Extended temp., Tape &amp; Reel, SOT-23 package            c) 11AA080-I/MS: 8-Kbit, 1.8V Serial EEPROM, Industrial temp., Standard address, MSOP package            d) 11LC020T-I/SN: 2-Kbit, 2.5V Serial EEPROM, Industrial temp., Tape &amp; Reel, Standard Address, SOIC package            e) 11AA040T-I/MNY: 4-Kbit, 1.8V Serial EEPROM, Industrial temp., Tape and Reel, Standard Address, 2 x 3 mm TDFN package, Nickel Palladium Gold finish            f) 11LC161-I/SN: 16-Kbit, 2.5V Serial EEPROM, Industrial temp., Alternate address, SOIC package            g) 11AA020T-I/CS16K: 2-Kbit, 1.8V Serial EEPROM, Industrial temp., Standard address, Chip Scale package</p> <p><b>Note 1:</b> Tape and Reel identifier only appears in the catalog part number description. This identifier is used for ordering purposes and is not printed on the device package. Check with your Microchip Sales Office for package availability with the Tape and Reel option.  <b>2:</b> "Y" indicates a Nickel Palladium Gold (NiPdAu) finish.  <b>3:</b> "16K" indicates 160K technology.</p>					

# 11AAXXX/11LCXXX

## PRODUCT IDENTIFICATION SYSTEM (AUTOMOTIVE)

To order or obtain information, e.g., on pricing or delivery, refer to the factory or the listed sales office.

PART NO.	X	X <sup>(1)</sup>	—	X	/XXX	XXX <sup>(2,3)</sup>																																																												
Device	Device Address	Tape & Reel	Temperature Range	Package	Variant																																																													
<table border="1" style="width: 100%; border-collapse: collapse;"> <tr> <td style="width: 15%;"><b>Device:</b></td> <td>11LC08 =</td> <td colspan="5">8-Kbit, 2.5V UNI/O Serial EEPROM</td> </tr> <tr> <td><b>Device Address:</b></td> <td>0 =</td> <td colspan="5">Standard Address – 0xA0</td> </tr> <tr> <td rowspan="2"><b>Tape &amp; Reel:</b></td> <td>T =</td> <td colspan="5">Tape and Reel<sup>(1)</sup></td> </tr> <tr> <td>Blank =</td> <td colspan="5">Tube</td> </tr> <tr> <td rowspan="2"><b>Temperature Range:</b></td> <td>I =</td> <td>-40°C to</td> <td>+85°C</td> <td colspan="3">AEC-Q100 Grade 3</td> </tr> <tr> <td>E =</td> <td>-40°C to</td> <td>+125°C</td> <td colspan="3">AEC-Q100 Grade 1</td> </tr> <tr> <td><b>Package:</b></td> <td>TT =</td> <td colspan="5">3-lead SOT-23 (Tape and Reel only)</td> </tr> <tr> <td rowspan="2"><b>Variant<sup>(2,3)</sup>:</b></td> <td>16KVAO =</td> <td colspan="5">Standard Automotive, 16K Process</td> </tr> <tr> <td>16KVXX =</td> <td colspan="5">Customer-Specific Automotive, 16K Process</td> </tr> </table>							<b>Device:</b>	11LC08 =	8-Kbit, 2.5V UNI/O Serial EEPROM					<b>Device Address:</b>	0 =	Standard Address – 0xA0					<b>Tape &amp; Reel:</b>	T =	Tape and Reel <sup>(1)</sup>					Blank =	Tube					<b>Temperature Range:</b>	I =	-40°C to	+85°C	AEC-Q100 Grade 3			E =	-40°C to	+125°C	AEC-Q100 Grade 1			<b>Package:</b>	TT =	3-lead SOT-23 (Tape and Reel only)					<b>Variant<sup>(2,3)</sup>:</b>	16KVAO =	Standard Automotive, 16K Process					16KVXX =	Customer-Specific Automotive, 16K Process				
<b>Device:</b>	11LC08 =	8-Kbit, 2.5V UNI/O Serial EEPROM																																																																
<b>Device Address:</b>	0 =	Standard Address – 0xA0																																																																
<b>Tape &amp; Reel:</b>	T =	Tape and Reel <sup>(1)</sup>																																																																
	Blank =	Tube																																																																
<b>Temperature Range:</b>	I =	-40°C to	+85°C	AEC-Q100 Grade 3																																																														
	E =	-40°C to	+125°C	AEC-Q100 Grade 1																																																														
<b>Package:</b>	TT =	3-lead SOT-23 (Tape and Reel only)																																																																
<b>Variant<sup>(2,3)</sup>:</b>	16KVAO =	Standard Automotive, 16K Process																																																																
	16KVXX =	Customer-Specific Automotive, 16K Process																																																																
						<b>Examples:</b> a) 11LC080T-E/TT16KVAO: 8-Kbit, 2.5V Serial EEPROM, Tape and Reel, Automotive Grade 1, Standard address, SOT-23 package																																																												
						<b>Note 1:</b> Tape and Reel identifier only appears in the catalog part number description. This identifier is used for ordering purposes and is not printed on the device package. Check with your Microchip Sales Office for package availability with the Tape and Reel option. <b>2:</b> The VAO/VXX automotive variants have been designed, manufactured, tested and qualified in accordance with AEC-Q100 requirements for automotive applications. <b>3:</b> For customers requesting a PPAP, a customer-specific part number will be generated and provided. A PPAP is not provided for VAO part numbers.																																																												

---

---

**Note the following details of the code protection feature on Microchip products:**

- Microchip products meet the specifications contained in their particular Microchip Data Sheet.
- Microchip believes that its family of products is secure when used in the intended manner, within operating specifications, and under normal conditions.
- Microchip values and aggressively protects its intellectual property rights. Attempts to breach the code protection features of Microchip product is strictly prohibited and may violate the Digital Millennium Copyright Act.
- Neither Microchip nor any other semiconductor manufacturer can guarantee the security of its code. Code protection does not mean that we are guaranteeing the product is "unbreakable" Code protection is constantly evolving. Microchip is committed to continuously improving the code protection features of our products.

---

This publication and the information herein may be used only with Microchip products, including to design, test, and integrate Microchip products with your application. Use of this information in any other manner violates these terms. Information regarding device applications is provided only for your convenience and may be superseded by updates. It is your responsibility to ensure that your application meets with your specifications. Contact your local Microchip sales office for additional support or, obtain additional support at <https://www.microchip.com/en-us/support/design-help/client-support-services>.

THIS INFORMATION IS PROVIDED BY MICROCHIP "AS IS". MICROCHIP MAKES NO REPRESENTATIONS OR WARRANTIES OF ANY KIND WHETHER EXPRESS OR IMPLIED, WRITTEN OR ORAL, STATUTORY OR OTHERWISE, RELATED TO THE INFORMATION INCLUDING BUT NOT LIMITED TO ANY IMPLIED WARRANTIES OF NON-INFRINGEMENT, MERCHANTABILITY, AND FITNESS FOR A PARTICULAR PURPOSE, OR WARRANTIES RELATED TO ITS CONDITION, QUALITY, OR PERFORMANCE.

IN NO EVENT WILL MICROCHIP BE LIABLE FOR ANY INDIRECT, SPECIAL, PUNITIVE, INCIDENTAL, OR CONSEQUENTIAL LOSS, DAMAGE, COST, OR EXPENSE OF ANY KIND WHATSOEVER RELATED TO THE INFORMATION OR ITS USE, HOWEVER CAUSED, EVEN IF MICROCHIP HAS BEEN ADVISED OF THE POSSIBILITY OR THE DAMAGES ARE FORESEEABLE. TO THE FULLEST EXTENT ALLOWED BY LAW, MICROCHIP'S TOTAL LIABILITY ON ALL CLAIMS IN ANY WAY RELATED TO THE INFORMATION OR ITS USE WILL NOT EXCEED THE AMOUNT OF FEES, IF ANY, THAT YOU HAVE PAID DIRECTLY TO MICROCHIP FOR THE INFORMATION.

Use of Microchip devices in life support and/or safety applications is entirely at the buyer's risk, and the buyer agrees to defend, indemnify and hold harmless Microchip from any and all damages, claims, suits, or expenses resulting from such use. No licenses are conveyed, implicitly or otherwise, under any Microchip intellectual property rights unless otherwise stated.

For information regarding Microchip's Quality Management Systems, please visit [www.microchip.com/quality](http://www.microchip.com/quality).

**Trademarks**

The Microchip name and logo, the Microchip logo, Adaptec, AVR, AVR logo, AVR Freaks, BesTime, BitCloud, CryptoMemory, CryptoRF, dsPIC, flexPWR, HELDO, IGLoo, JukeBlox, KeeLoq, Klear, LANCheck, LinkMD, maXStylus, maXTouch, MediaLB, megaAVR, Microsemi, Microsemi logo, MOST, MOST logo, MPLAB, OptoLyzer, PIC, picoPower, PICSTART, PIC32 logo, PolarFire, Prochip Designer, QTouch, SAM-BA, SenGenuity, SpyNIC, SST, SST Logo, SuperFlash, Symmetricom, SyncServer, Tachyon, TimeSource, tinyAVR, UNI/O, Vectron, and XMEGA are registered trademarks of Microchip Technology Incorporated in the U.S.A. and other countries.

AgileSwitch, APT, ClockWorks, The Embedded Control Solutions Company, EtherSynch, Flashtec, Hyper Speed Control, HyperLight Load, Libero, motorBench, mTouch, Powermite 3, Precision Edge, ProASIC, ProASIC Plus, ProASIC Plus logo, Quiet-Wire, SmartFusion, SyncWorld, Temux, TimeCesium, TimeHub, TimePictra, TimeProvider, TrueTime, and ZL are registered trademarks of Microchip Technology Incorporated in the U.S.A.

Adjacent Key Suppression, AKS, Analog-for-the-Digital Age, Any Capacitor, AnyIn, AnyOut, Augmented Switching, BlueSky, BodyCom, Clockstudio, CodeGuard, CryptoAuthentication, CryptoAutomotive, CryptoCompanion, CryptoController, dsPICDEM, dsPICDEM.net, Dynamic Average Matching, DAM, ECAN, Espresso T1S, EtherGREEN, GridTime, IdealBridge, In-Circuit Serial Programming, ICSP, INICnet, Intelligent Paralleling, IntelliMOS, Inter-Chip Connectivity, JitterBlocker, Knob-on-Display, KoD, maxCrypto, maxView, memBrain, Mindi, MiWi, MPASM, MPF, MPLAB Certified logo, MPLIB, MPLINK, MultiTRAK, NetDetach, Omniscient Code Generation, PICDEM, PICDEM.net, PICkit, PICtail, PowerSmart, PureSilicon, QMatrix, REAL ICE, Ripple Blocker, RTAX, RTG4, SAM-ICE, Serial Quad I/O, simpleMAP, SimpliPHY, SmartBuffer, SmartHLS, SMART-I.S., storClad, SQI, SuperSwitcher, SuperSwitcher II, Switchtec, SynchroPHY, Total Endurance, Trusted Time, TSHARC, USBCheck, VariSense, VectorBlox, VeriPHY, ViewSpan, WiperLock, XpressConnect, and ZENA are trademarks of Microchip Technology Incorporated in the U.S.A. and other countries.

SQTP is a service mark of Microchip Technology Incorporated in the U.S.A.

The Adaptec logo, Frequency on Demand, Silicon Storage Technology, and Symmcom are registered trademarks of Microchip Technology Inc. in other countries.

GestIC is a registered trademark of Microchip Technology Germany II GmbH & Co. KG, a subsidiary of Microchip Technology Inc., in other countries.

All other trademarks mentioned herein are property of their respective companies.

© 2011-2023, Microchip Technology Incorporated and its subsidiaries.

All Rights Reserved.

ISBN: 978-1-6683-2185-0



---

---

## Worldwide Sales and Service

---

---

### AMERICAS

**Corporate Office**  
2355 West Chandler Blvd.  
Chandler, AZ 85224-6199  
Tel: 480-792-7200  
Fax: 480-792-7277  
Technical Support:  
<http://www.microchip.com/support>  
Web Address:  
[www.microchip.com](http://www.microchip.com)

**Atlanta**  
Duluth, GA  
Tel: 678-957-9614  
Fax: 678-957-1455

**Austin, TX**  
Tel: 512-257-3370

**Boston**  
Westborough, MA  
Tel: 774-760-0087  
Fax: 774-760-0088

**Chicago**  
Itasca, IL  
Tel: 630-285-0071  
Fax: 630-285-0075

**Dallas**  
Addison, TX  
Tel: 972-818-7423  
Fax: 972-818-2924

**Detroit**  
Novi, MI  
Tel: 248-848-4000

**Houston, TX**  
Tel: 281-894-5983

**Indianapolis**  
Noblesville, IN  
Tel: 317-773-8323  
Fax: 317-773-5453  
Tel: 317-536-2380

**Los Angeles**  
Mission Viejo, CA  
Tel: 949-462-9523  
Fax: 949-462-9608  
Tel: 951-273-7800

**Raleigh, NC**  
Tel: 919-844-7510

**New York, NY**  
Tel: 631-435-6000

**San Jose, CA**  
Tel: 408-735-9110  
Tel: 408-436-4270

**Canada - Toronto**  
Tel: 905-695-1980  
Fax: 905-695-2078

### ASIA/PACIFIC

**Australia - Sydney**  
Tel: 61-2-9868-6733

**China - Beijing**  
Tel: 86-10-8569-7000

**China - Chengdu**  
Tel: 86-28-8665-5511

**China - Chongqing**  
Tel: 86-23-8980-9588

**China - Dongguan**  
Tel: 86-769-8702-9880

**China - Guangzhou**  
Tel: 86-20-8755-8029

**China - Hangzhou**  
Tel: 86-571-8792-8115

**China - Hong Kong SAR**  
Tel: 852-2943-5100

**China - Nanjing**  
Tel: 86-25-8473-2460

**China - Qingdao**  
Tel: 86-532-8502-7355

**China - Shanghai**  
Tel: 86-21-3326-8000

**China - Shenyang**  
Tel: 86-24-2334-2829

**China - Shenzhen**  
Tel: 86-755-8864-2200

**China - Suzhou**  
Tel: 86-186-6233-1526

**China - Wuhan**  
Tel: 86-27-5980-5300

**China - Xian**  
Tel: 86-29-8833-7252

**China - Xiamen**  
Tel: 86-592-2388138

**China - Zhuhai**  
Tel: 86-756-3210040

### ASIA/PACIFIC

**India - Bangalore**  
Tel: 91-80-3090-4444

**India - New Delhi**  
Tel: 91-11-4160-8631

**India - Pune**  
Tel: 91-20-4121-0141

**Japan - Osaka**  
Tel: 81-6-6152-7160

**Japan - Tokyo**  
Tel: 81-3-6880-3770

**Korea - Daegu**  
Tel: 82-53-744-4301

**Korea - Seoul**  
Tel: 82-2-554-7200

**Malaysia - Kuala Lumpur**  
Tel: 60-3-7651-7906

**Malaysia - Penang**  
Tel: 60-4-227-8870

**Philippines - Manila**  
Tel: 63-2-634-9065

**Singapore**  
Tel: 65-6334-8870

**Taiwan - Hsin Chu**  
Tel: 886-3-577-8366

**Taiwan - Kaohsiung**  
Tel: 886-7-213-7830

**Taiwan - Taipei**  
Tel: 886-2-2508-8600

**Thailand - Bangkok**  
Tel: 66-2-694-1351

**Vietnam - Ho Chi Minh**  
Tel: 84-28-5448-2100

### EUROPE

**Austria - Wels**  
Tel: 43-7242-2244-39  
Fax: 43-7242-2244-393

**Denmark - Copenhagen**  
Tel: 45-4485-5910  
Fax: 45-4485-2829

**Finland - Espoo**  
Tel: 358-9-4520-820

**France - Paris**  
Tel: 33-1-69-53-63-20  
Fax: 33-1-69-30-90-79

**Germany - Garching**  
Tel: 49-8931-9700

**Germany - Haan**  
Tel: 49-2129-3766400

**Germany - Heilbronn**  
Tel: 49-7131-72400

**Germany - Karlsruhe**  
Tel: 49-721-625370

**Germany - Munich**  
Tel: 49-89-627-144-0  
Fax: 49-89-627-144-44

**Germany - Rosenheim**  
Tel: 49-8031-354-560

**Israel - Ra'anana**  
Tel: 972-9-744-7705

**Italy - Milan**  
Tel: 39-0331-742611  
Fax: 39-0331-466781

**Italy - Padova**  
Tel: 39-049-7625286

**Netherlands - Drunen**  
Tel: 31-416-690399  
Fax: 31-416-690340

**Norway - Trondheim**  
Tel: 47-7288-4388

**Poland - Warsaw**  
Tel: 48-22-3325737

**Romania - Bucharest**  
Tel: 40-21-407-87-50

**Spain - Madrid**  
Tel: 34-91-708-08-90  
Fax: 34-91-708-08-91

**Sweden - Gothenberg**  
Tel: 46-31-704-60-40

**Sweden - Stockholm**  
Tel: 46-8-5090-4654

**UK - Wokingham**  
Tel: 44-118-921-5800  
Fax: 44-118-921-5820