

Dimensional tolerances(mm)					Length tolerances(mm)				0.1/10 ±2°
0 ~ 30	>30 ~ 60	>60 ~ 100	>100 ~ 150	>150	0 ~ 5000	>5000 ~ 10000	>10000 ~ 30000	>30000	
±0.25	±0.35	±0.55	±0.80	±1.10	±55	±105	±205	±505	

额定电压/Rated Voltage	DC300V/5A
额定绝缘电压/Rated insulation Voltage	500V
额定脉冲电压/Rated impulse Voltage(V)	2.5KV
绝缘电阻/Insulation Resistance	≥200MΩ
插拔次数/Mechanical working life(mating cycles)	≥100
使用温度范围/Operating temperature(°C)	-40~+105
防水等级/Levels of protection	IP67(Mated)
接线方式/Terminal	Crimp
线径范围/Wire range(AWG/mm²)	22-18(0.3-0.8)
线缆直径/Cable diameter(mm)	1.3-2.8
符合RoHS环保要求/Conform to RoHS	Yes

Transfer or duplication of this document as well as the utilization or communication of its contents are prohibited unless authorized in advance. Violations will be held responsible. All rights reserved for patent, utility model or design registrations. 除专利、实用新型、外观设计、发明专利、软件著作权、集成电路布图设计专有权、商业秘密和发明创造等知识产权的所有权外，其他权利均归本公司所有。

图纸版本	ECN	变更描述	设计人	设计日期
REV	ECN	DESCRIPTION	DRFT	DATE

APPD: Liu Jian	2024-05-30
CHKD: Zhai Peng	2024-05-30
DRFT: Zhou Yizhi	2024-05-30

MATERIAL: /		SURFACE/COLOR: /	
MAT NO./REV: 28040000240 / 00		MAT STATUS: /	
NAME ETP-05A-P12-C-GY-01			
DRAWING NO.	TYPE	DRAWING STATUS	SCALE
/	/	/	1:1
SHEET		1/1	

Dimensional tolerances(mm)				Length tolerances(mm)				0.1/10 ±2°
0	>30	>60	>100	0	>5000	>10000	>30000	
-	-	-	-	-	-	-	-	
±0.25	±0.35	±0.55	±0.80	±1.10	±55	±105	±205	±505

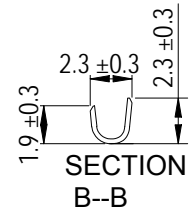
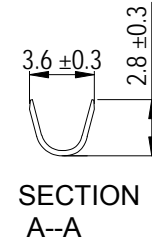
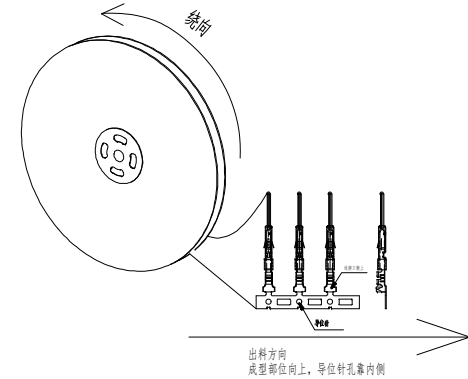
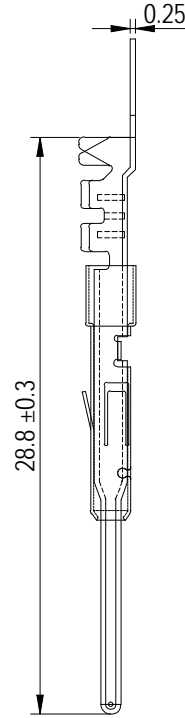
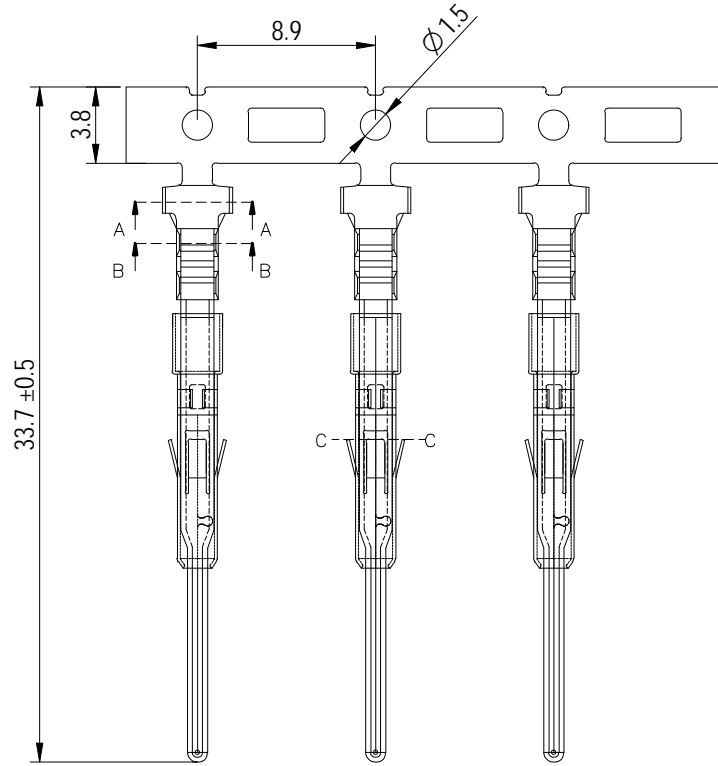

- Crimp contacts
 01.Material :Copper alloy
 02.Surface :Tin-plated
 03.Contact resistance :≤5mΩ
 04.Terminal :Crimping
 05.Wire gauge :0.3~0.8mm(AWG 22~18)
 06.Rohs Compliance

		MATERIAL: C5191-H+SUS301	SURFACE/COLOR: 镀锡		
		MAT NO./REV: 28030000027 / 版本	MAT STATUS: 物料状态		
APPD: Liu J	2024-04-28	NAME			
CHKD: Zhai P	2024-04-28	5A-TM (STAMPING)			
DRFT: Yu KW	2024-04-28	DRAWING NO.	TYPE	DRAWING STATUS	SCALE
		图号	图纸类型	图纸状态	SHEET
					3:1
					1/1

图纸版本	ECN	变更描述	设计人	设计日期
REV	ECN	DESCRIPTION	DRFT	DATE

Transfer or duplication of this document as well as the utilization or communication of its contents are prohibited unless authorized in writing by Degson. All rights reserved for patent. 除专利等明确标注外, 未经授权, 不得复制或传播。 凡在本公司网站或文件内标注的专利, 均受法律保护。 未经授权, 不得复制或传播。 凡在本公司网站或文件内标注的专利, 均受法律保护。 未经授权, 不得复制或传播。

Dimensional tolerances(mm)					Length tolerances(mm)				0.1/10 ±2°
0	>30	>60	>100	>150	0	>5000	>10000	>30000	
-	-	-	-	-	-	-	-	-	
±0.25	±0.35	±0.55	±0.80	±1.10	±55	±105	±205	±505	

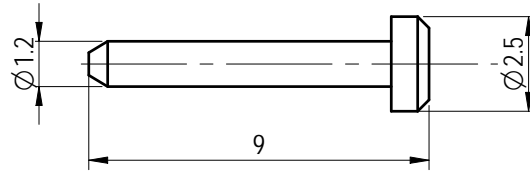
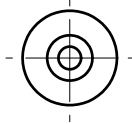
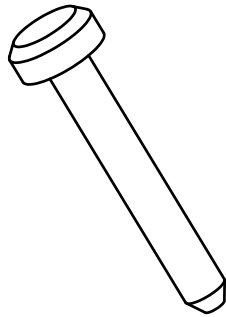

Notes

- 01.Material : PC+20%GF
- 02.Color : Greyish-white
- 03.Rohs Compliance

		MATERIAL: /	SURFACE/COLOR: 镀雾锡		
APPD: Liu J	2024-04-28	MAT NO./REV: 28040000272 / 版本	MAT STATUS: 物料状态		
CHKD: Zhai P	2024-04-28	NAME ETP-DT			
DRFT: Yu KW	2024-04-28	DRAWING NO.	TYPE	DRAWING STATUS	SCALE
A4		图号	图纸类型	图纸状态	SHEET
					3:1
					1/1

图纸版本	ECN	变更描述	设计人	设计日期
REV	ECN	DESCRIPTION	DRFT	DATE

Transfer or duplication of this document or communication of its contents are prohibited unless expressly permitted. Violations will be treated as copyright infringement. All rights reserved for patent, utility model or design registrations. 除专利权明确授权，否则禁止转让、复制、引用、交流本文件的内容。未经明确许可，任何复制或内网发布的行为均视为侵权。

Transfer or duplication of this document as well as the utilization or communication of its contents are prohibited unless authorized in writing by Degson. All rights reserved for patent. 除专利注明情况外，未经许可，不得复制或传播。 凡在本公司网站或产品说明书中出现的商标、商号、名称、型号、规格等均为该公司的所有权利。

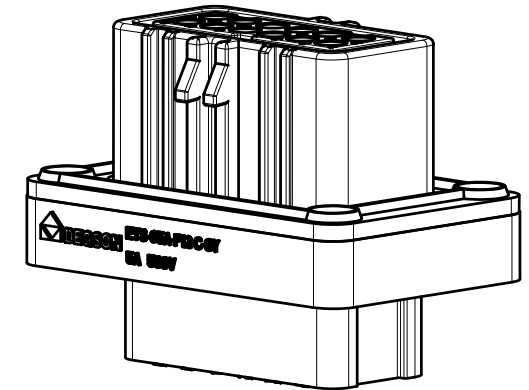
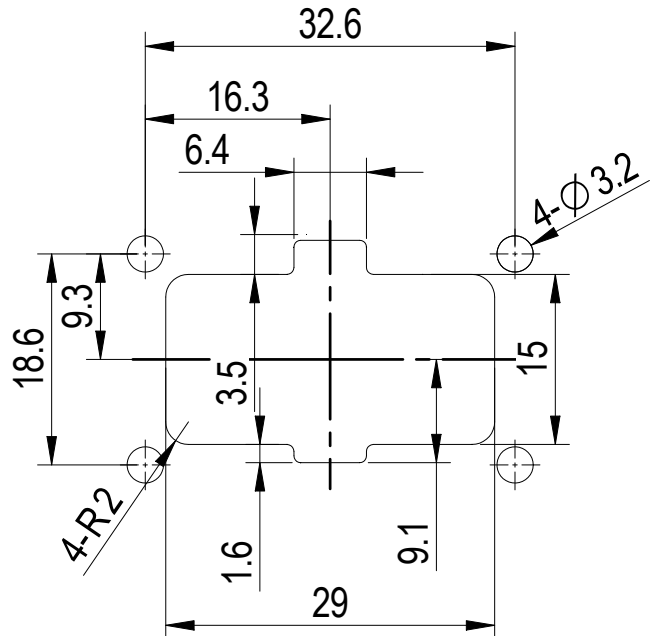
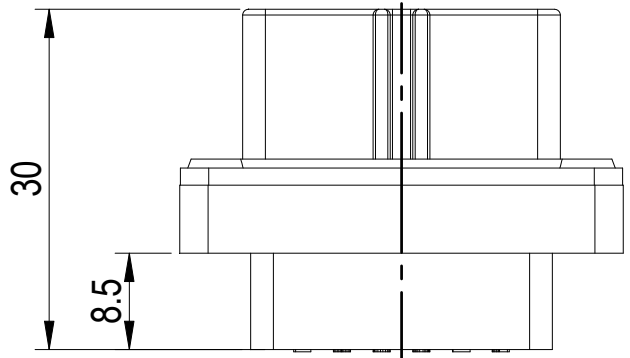
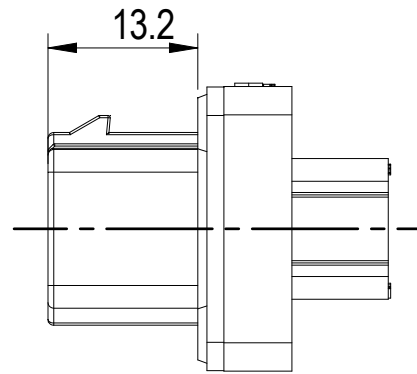
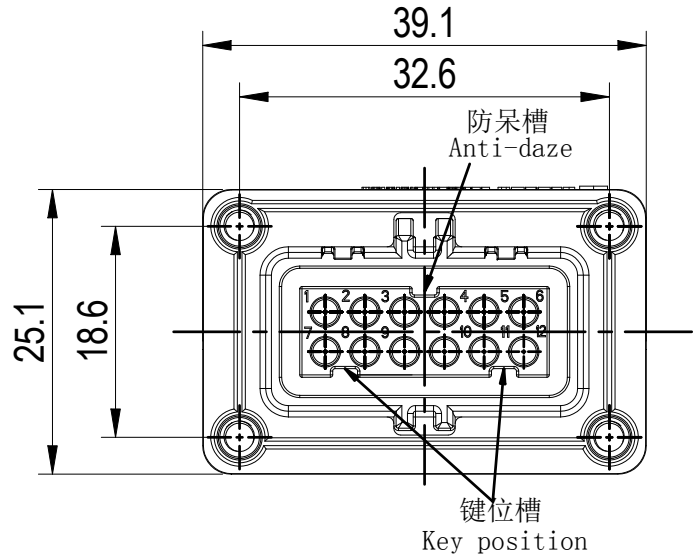

Dimensional tolerances(mm)					Length tolerances(mm)				0.1/10 ±2°
0	>30	>60	>100	>150	0	>5000	>10000	>30000	
±0.25	±0.35	±0.55	±0.80	±1.10	±55	±105	±205	±505	
额定电压/Rated Voltage/Current									DC300V/5A
额定绝缘电压/Rated insulation Voltage									500V
额定脉冲电压/Rated impulse Voltage(V)									2.5KV
绝缘电阻/Insulation Resistance									≥200MΩ
插拔次数/Mechanical working life(mating cycles)									≥100
使用温度范围/Operating temperature(°C)									-40~+105
防水等级/Levels of protection									IP67(Mated)
接线方式/Terminal									Crimp
线径范围/Wire range(AWG/mm²)									22-18(0.3-0.8)
线径直径/Cable diameter(mm)									1.3-2.8
符合RoHS环保要求/Conform to RoHS									Yes

图纸版本	ECN	变更描述	设计人	设计日期
REV	ECN	DESCRIPTION	DRFT	DATE

		MATERIAL: /	SURFACE/COLOR: /		
APPD: Liu Jian 2024-05-30		MAT NO./REV: 28040000242 / 00	MAT STATUS: /		
CHKD: Zhai Peng 2024-05-30		NAME			
DRFT: Zhou Yizhi 2024-05-30		ETS-05A-P12-C-GY-01			
DRAWING NO.	TYPE	DRAWING STATUS	SCALE	SHEET	
/	/	/	1.5:1	1/1	

Dimensional tolerances(mm)					Length tolerances(mm)				0.1/10 ±2°
0	>30	>60	>100	>150	0	>5000	>10000	>30000	
-	-	-	-	-	-	-	-	-	
±0.25	±0.35	±0.55	±0.80	±1.10	±55	±105	±205	±505	

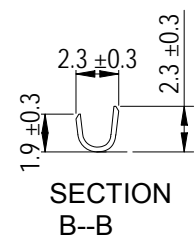
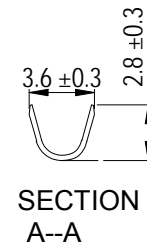
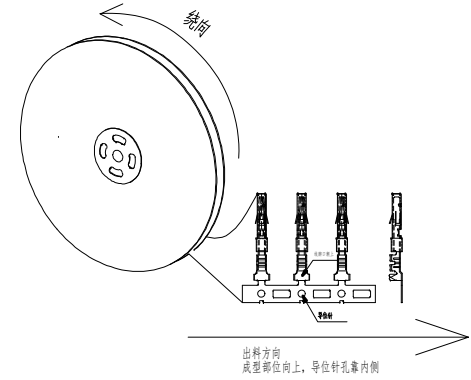
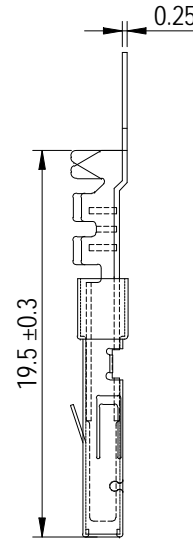
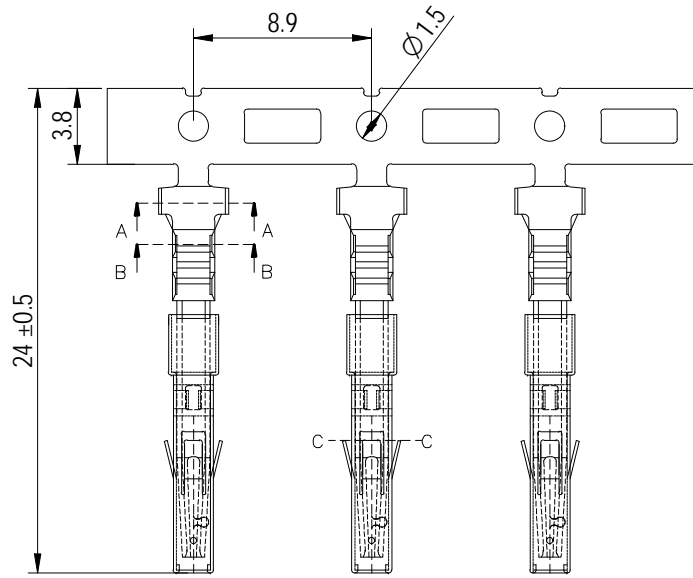

- Crimp contacts
- 01.Material :Copper alloy
- 02.Surface :Tin-plated
- 03.Contact resistance :≤5mΩ
- 04.Terminal :Crimping
- 05.Wire gauge :0.3~0.8mm(AWG 22~18)
- 06.Rohs Compliance

		MATERIAL: C5191-H+SUS301	SURFACE/COLOR: 镀雾锡			
		MAT NO./REV: 28030000026 / 版本	MAT STATUS: 物料状态			
APPD: Liu J	2024-04-28	NAME				
CHKD: Zhai P	2024-04-28	5A-TF (STAMPING)				
DRFT: Yu KW	2024-04-28					
图号	图纸类型	DRAWING NO.	TYPE	DRAWING STATUS	SCALE	SHEET
图号	图纸类型	图号	图纸类型	图纸状态	3:1	1/1

图纸版本	ECN	变更描述	设计人	设计日期
REV	ECN	DESCRIPTION	DRFT	DATE

Transfer or duplication of this document as well as the utilization or communication of its contents are prohibited unless authorized in writing by Degson. All rights reserved for patent. 除专利等明确标注外, 未经许可, 不得复制或传播。 未经授权, 不得复制或传播。 未经授权, 不得复制或传播。 未经授权, 不得复制或传播。